



Materiale elettrico e fanaleria

Electrical and lightning

Ricambi & accessori per macchine
agricole / *Spare parts & accessories
for agricultural machine*







AMA Group è una realtà industriale internazionale con oltre 55 anni di esperienza nella **progettazione e produzione di componenti e sistemi per macchine agricole e industriali off-road**. Il Gruppo supporta i costruttori OEM attraverso le Business Unit Componenti Cabina e Componenti Meccanici, offrendo competenze integrate negli interni cabina, nella meccanica e nella mecatronica, e gestendo l'intero sviluppo del prodotto, dalla progettazione all'industrializzazione.

AMA è inoltre uno dei principali player nel settore aftermarket grazie alla Business Unit Aftermarket e Distribuzione, che mette a disposizione una delle gamme prodotto più ampie del settore. Il Gruppo opera anche nel mercato delle costruzioni attraverso la Business Unit Edilizia, sviluppando soluzioni dedicate alle specifiche esigenze applicative dei cantieri.

Con una struttura composta da 40 stabilimenti e filiali nel mondo, tra cui 23 siti produttivi (17 in Italia e 6 all'estero) e 17 filiali distributive e uffici commerciali, il Gruppo impiega oltre 1.652 persone e opera a livello globale, garantendo qualità, affidabilità e continuità di fornitura ai propri clienti.

AMA Group is an international industrial company with over 55 years of experience in **engineering and manufacturing components and systems for off-road agricultural and industrial machinery**. The Group supports OEM manufacturers through its Cabin Components and Mechanical Components Business Units, offering integrated expertise in cab interiors, mechanics and mechatronics, managing product development from design to industrialization.

AMA is also one of the main players in the aftermarket sector through its Aftermarket & Distribution Business Unit, providing one of the widest product ranges in the industry. The Group also operates in the construction sector through its Building Materials Business Unit, developing solutions tailored to the specific application needs of construction sites.

With a structure composed of 40 plants and branches worldwide – including 23 production sites (17 in Italy and 6 abroad) and 17 distribution branches and commercial offices – the Group employs more than 1.652 people and operates globally, guaranteeing quality, reliability and continuity of supply to its customers.



80.000

clienti attivi in 90 paesi
active customers in 90 countries

525.000

referenze destinate ai mercati OEM e After Market
products destined for the OEM and After Market sectors

243 milioni

fatturato complessivo
overall turnover

8

diverse linee di prodotto suddivise in 4 Business Unit
different product ranges spread across 4 Business Units



23

stabilimenti produttivi
production plants

1.652

dipendenti
employees

14

filiali nel mondo
branches across the world

3

uffici commerciali nel mondo
worldwide sales offices

LOGISTICA

Il dipartimento Logistica & Customer Service opera quotidianamente a stretto contatto con il cliente e con i diversi dipartimenti aziendali per garantire tempestività e spedizioni complete. La struttura è dotata di dispositivi e infrastrutture per la preparazione automatizzata degli ordini, che aumentano le performance di servizio e la precisione in fase di preparazione. Il Customer Service è parte integrante del sistema logistico, specializzato e organizzato appositamente in base alle diverse esigenze della clientela Agri e Garden.

LOGISTICS

Every day, the Logistics & Customer Service department works in close contact with customers and AMA departments to ensure timeliness and completeness of shipments. The whole logistics and manufacturing facility is equipped with devices and infrastructure for the automated preparation of orders, enabling continuity of service while increasing performance and accuracy in order preparation. Customer Service is an integral part of the logistics system, specifically specialized and organized according to the different needs of Agri and Garden customers.

BUSINESS UNITS

BUSINESS UNIT COMPONENTI CABINA

Raccoglie le competenze del Gruppo dedicate allo sviluppo di soluzioni per l'ambiente cabina destinate agli OEM. Elettronica e HMI, braccioli, sistemi di sterzo, cablaggi, componenti plastici, sedili e accessori convergono in un'offerta integrata, progettata per coniugare tecnologia, comfort e qualità percepita. In stretta sinergia con il cliente, la Business Unit gestisce l'intero processo di sviluppo, dal concept alla validazione fino alla produzione, dando forma a soluzioni affidabili e perfettamente integrate nelle piattaforme OEM.

BUSINESS UNIT COMPONENTI MECCANICI

Raccoglie il know-how del Gruppo nella trasmissione della potenza, nella movimentazione e nelle strutture delle macchine agricole e delle attrezzature. La Business Unit progetta componenti e sistemi meccanici e idraulici sviluppati per garantire robustezza, continuità operativa e piena compatibilità con le applicazioni OEM. L'esperienza tecnica e l'integrazione verticale dei siti produttivi consentono di governare l'intero ciclo industriale, dall'ingegnerizzazione alla produzione, assicurando qualità costante e flessibilità produttiva.

BUSINESS UNIT AFTERMARKET E DISTRIBUZIONE

Rappresenta il sistema di servizio con cui il Gruppo assicura continuità operativa alle macchine in campo. Una rete distributiva globale, un catalogo esteso e una logistica evoluta garantiscono disponibilità dei componenti, tempestività nelle forniture e assistenza tecnica qualificata. Con una proposta dedicata ai settori dell'agricoltura e del giardinaggio, la Business Unit rende il servizio una leva concreta di valore per rivenditori, professionisti e operatori dell'aftermarket.

BUSINESS UNIT EDILIZIA

Riunisce le attività del Gruppo rivolte al mercato delle costruzioni, con una proposta tecnica destinata a operatori professionali e imprese. Materiali isolanti, prodotti per finiture e soluzioni vernicianti compongono un portafoglio specializzato, sviluppato per rispondere alle esigenze applicative del cantiere. Canali distributivi dedicati e competenze consolidate completano un'offerta che coniuga affidabilità, performance e qualità d'impiego.

CABIN COMPONENTS BUSINESS UNIT

Represents the Group's expertise dedicated to the development of cab environment solutions for OEMs. Electronics and HMIs, armrests, steering systems, wiring harnesses, plastic components, seats and accessories come together in an integrated offering designed to combine technology, comfort and perceived quality. Working in close synergy with the customer, the BU manages the entire development process, from concept to validation through to production, delivering reliable solutions fully integrated into OEM platforms.

MECHANICAL COMPONENTS BUSINESS UNIT

Represents the Group's expertise in power transmission, motion systems and structural components for agricultural machinery and equipment. The Business Unit designs mechanical and hydraulic components and systems developed to ensure robustness, operational continuity and full compatibility with OEM applications. Technical expertise and the vertical integration of production sites enable full control of the industrial cycle, from engineering to production, ensuring consistent quality and manufacturing flexibility.

AFTERMARKET & DISTRIBUTION BUSINESS UNIT

Represents the Group's expertise in service systems ensuring the continuous operation of machinery in the field. A global distribution network, an extensive catalogue and advanced logistics ensure parts availability, timely deliveries and qualified technical support. With a dedicated offering for the agriculture and gardening sectors, the Business Unit turns service into a tangible value driver for dealers, professionals and aftermarket operators.

BUILDING MATERIALS BUSINESS UNIT

Represents the Group's expertise dedicated to the construction market, with a technical offering tailored to professionals and companies. Insulation materials, finishing products and coating solutions form a specialized portfolio developed to meet the application needs of construction sites. Dedicated distribution channels and consolidated expertise complete an offer that combines reliability, performance and quality in use.



TLF

Centralino - Ama Operator

+39 0522 6369, +39 0522 6363,
+39 0522 057911



Vendite Italia

Sales - Italian Territory

0522 636313, 0522 636354,
0522 636360, 0522 636920



Ufficio Reclami

Customer Support

+39 0522 636383 - 0522 636926



FAX

Generico - General

+39 0522 695753



Fax Vendite Italia

Fax Sales - Italian Territory

0522 696059



Fax Vendite Estero

Fax Sales - Export

+39 0522 646241
+39 0522 638348



Ordini mail
Mail orders
cs.am@ama.it

Ordini Online - Online orders

Accedi al portale e-commerce e ordina online: **shop.ama.it**

Richiedi la tua password a **cs.am@ama.it** o contatta l'agente di zona.

Access to the e-commerce website and order online: **shop.ama.it**

Please, request your password to **cs.am@ama.it** or contact your AMA local agent.

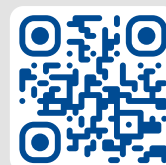

INDICE / INDEX

| | |
|--|------------|
| Batterie e accessori <i>Batteries and accessories</i> | 5 |
| Girofari e piantoni <i>Beacons and beacon holders</i> | 36 |
| Fari da lavoro <i>Work lights</i> | 55 |
| Fanali <i>Lights</i> | 82 |
| Kit luci e rimorchi <i>Light kits for trailers and agricultural vehicles</i> | 135 |
| Pannelli e catadiottri <i>Warning panels and reflectors</i> | 154 |
| Prese e spine <i>Sockets and plugs</i> | 166 |
| Intermittenze, centraline e relays <i>Flashers, control units, relays</i> | 174 |
| Spie di controllo e strumenti <i>Control lights and gauges</i> | 181 |
| Lampadine <i>Bulbs</i> | 217 |
| Cavi elettrici e guaine <i>Electric cables and sleeves</i> | 224 |
| Accessori cablaggio elettrico <i>Electrical wiring accessories</i> | 228 |
| Avvisatori acustici <i>Audible warning devices</i> | 246 |
| Sistemi video <i>Camera systems</i> | 250 |
| Accessori cabina <i>Cabin accessories</i> | 256 |
| Alternatori e regolatori <i>Alternators and voltage regulators</i> | 262 |



Batterie e accessori

Batteries and accessories

I prodotti recanti il marchio AMA qui indicati sono realizzati da AMA S.p.A. e destinati a essere utilizzati come ricambi adattabili e non originali. I riferimenti a marchi, codici originali e costruttori di terzi, riportati in corrispondenza degli articoli AMA compatibili, hanno esclusivamente la finalità di identificare il modello, l'applicazione o la destinazione d'uso del prodotto, in conformità a quanto previsto dal Regolamento (CE) n. 1400/2002 e dalla normativa vigente in materia di concorrenza e uso lecito dei marchi di terzi. / The products bearing the AMA brand name listed here are manufactured by AMA S.p.A. and are intended for use as adaptable, non-original spare parts. References to trademarks, original codes and third-party manufacturers, shown alongside compatible AMA items, are intended solely to identify the model, application or intended use of the product, in accordance with Regulation (EC) No. 1400/2002 and current legislation on competition and the lawful use of third-party trademarks.

BATTERIE RDX ENERGY 12V

RDX ENERGY BATTERIES 12V
 BATTERIES RDX ENERGY 12V
 RDX ENERGY-BATTERIEN 12V
 BATERÍAS RDX ENERGY 12V

| Skü | img. | Linea / Line | Capacità batteria / Battery capacity | Spunto / Cue | Terminali / Terminals | Fissaggio / Fastening | Dimensioni (mm) / Dimensions (mm) | Polarità positiva / Positive polarity |
|-------|------|--------------|---|--------------|--------------------------|--------------------------|--------------------------------------|---------------------------------------|
| 55502 | | Automotive | 45 Ah | 360 A | T1 | B13 | 207x175x190 | |
| 55503 | | Automotive | 45 Ah | 480 A | T1 | B13 | 207x175x175 | |
| 55504 | | Automotive | 55 Ah | 480 A | T1 | B13 | 242x175x190 | |
| 55520 | | Automotive | 60 Ah | 500 A | T1 | B13 | 241x175x190 | |
| 55528 | | Automotive | 61 Ah | 550 A | T1 | B13 | 241x174,5x190 | |
| 55505 | | Automotive | 72 Ah | 690 A | T1 | B13 | 277x175x175 | |
| 55506 | | Automotive | 78 Ah | 720 A | T1 | B13 | 276x175x190 | |
| 55507 | | Automotive | 85 Ah | 850 A | T1 | B13 | 313x175x175 | |
| 55508 | | Automotive | 90 Ah | 810 A | T1 | B13 | 352x175x175 | |
| 55509 | | Automotive | 92 Ah | 850 A | T1 | B13 | 313x175x190 | |

| SKU | img. | Linea / Line | Capacità batteria / Battery capacity | Spunto / Cue | Terminali / Terminals | Fissaggio / Fastening | Dimensioni (mm) / Dimensions (mm) | Polarità positiva / Positive polarity |
|---------|------|--------------|---|--------------|--------------------------|--------------------------|--------------------------------------|---------------------------------------|
| 55510 | | Automotive | 98 Ah | 850 A | T1 | B13 | 352x174,5x190 | |
| 55510SX | | Automotive | 98 Ah | 850 A | T1 | B13 | 352x174,5x190 | |
| 55511 | | Automotive | 100 Ah | 850 | T1 | B01 | 303x175x227 | |
| 55512 | | Automotive | 100 Ah | 850 A | T1 | B01 | 303x175x227 | |
| 55523 | | Automotive | 100 Ah | 850 A | T1 | B13 | 313x175x190 | |
| 55525 | | Truck | 100 Ah | 850 A | T1 | B13 | 315x174,5x190 | |
| 55513 | | Truck | 110 Ah | 950 A | T1 | B00 | 329,5x171,5x240 | |
| 55529 | | Truck | 110 Ah | 800 A | T1 | B01 | 344x175x232 | |
| 55514 | | Truck | 125 Ah | 920 A | T1 | B01 | 344x175x232 | |
| 55527 | | Truck | 125 Ah | 920 A | T1 | B03 | 514x175x212 | |
| 55517A | | Truck | 130 Ah | 950 A | T1 | B01 | 508x175x205 | |

| Skü | img. | Linea / Line | Capacità batteria / Battery capacity | Spunto / Cue | Terminali / Terminals | Fissaggio / Fastening | Dimensioni (mm) / Dimensions (mm) | Polarità positiva / Positive polarity |
|--------|------|--------------|---|--------------|--------------------------|--------------------------|--------------------------------------|---------------------------------------|
| 55515 | | Truck | 135 Ah | 800 A | T1 | B03 | 509x175x204 | |
| 55524 | | Truck | 135 Ah | 800 A | T1 | B00 | 512,5x188,5x217,5 | |
| 55526 | | Truck | 140 Ah | 970 A | T1 | B01 | 508x189x210 | |
| 55516 | | Truck | 145 Ah | 850 A | T1 | B03 | 509x175x204 | |
| 55518 | | Truck | 170 Ah | 1000 A | T1 | B00 | 512,5x223,5x217,5 | |
| 55519A | | Truck | 190 Ah | 1250 A | T1 | B00 | 510x218x225 | |
| 55522 | | Truck | 200 Ah | 1150 A | T1 | B00 | 513x287x235 | |



BATTERIE RDX ENERGY START & STOP

RDX ENERGY START & STOP BATTERIES
 BATTERIES RDX ENERGY START & STOP
 RDX ENERGY START & STOP BATTERIEN
 BATERÍAS RDX ENERGY START & STOP

| Skü | img. | Linea / Line | Capacità batteria / Battery capacity | Spunto / Cue | Terminali / Terminals | Fissaggio / Fastening | Dimensioni (mm) / Dimensions (mm) | Polarità positiva / Positive polarity |
|-------|------|---------------------|---|--------------|--------------------------|--------------------------|--------------------------------------|---------------------------------------|
| 68020 | | EFB Start & Stop | 60 Ah | 580 A | T1 | B13 | 241,5x174,5x189,5 | |
| 68021 | | EFB Start & Stop | 72 Ah | 760 | T1 | B13 | 276x174,5x190 | |

BATTERIE RDX ENERGY GARDEN

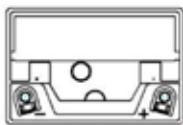
RDX ENERGY GARDEN BATTERIES
 BATTERIES RDX ENERGY GARDEN
 RDX ENERGY GARDEN BATTERIEN
 BATERÍAS RDX ENERGY GARDEN

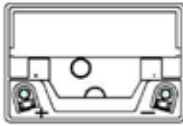
| Skü | img. | Capacità batteria / Battery capacity | Terminali / Terminals | Fissaggio / Fastening | Dimensioni / Dimensions | Polarità positiva / Positive polarity |
|-------|---|--------------------------------------|-----------------------|-----------------------|-------------------------|---|
| 55530 |  | 30 Ah | T4 | B00 | 196x128x184 mm |  |
| 55531 |  | 30 Ah | T4 | B00 | 196x128x184 mm |  |

ESPOSITORE BATTERIE RDX ENERGY

RDX ENERGY BATTERY DISPLAY
 PRÉSENTOIR POUR BATTERIES RDX ENERGY
 BATTERIE-AUSSTELLER RDX ENERGY
 EXPOSITOR DE BATERÍAS RDX ENERGY



| Skü | Dimensioni / Dimensions | Peso / Weight |
|-------|-------------------------|---------------|
| 61499 | 80x48x153 cm | 17 kg |

BATTERIE EXIDE-TUDOR

 EXIDE-TUDOR BATTERIES
 BATTERIES EXIDE-TUDOR
 EXIDE-TUDOR BATTERIEN
 BATERÍAS EXIDE-TUDOR

| Skü | img. | Linea / Line | Capacità batteria / Battery capacity | Spunto / Cue | Terminali / Terminals | Fissaggio / Fastening | Dimensioni / Dimensions | Polarità positiva / Positive polarity |
|-------|------|-------------------------|---|--------------|--------------------------|--------------------------|----------------------------|---------------------------------------|
| 64000 | | Technica | 44 Ah | 420 A | T1 | B13 | 207X175X175 | |
| 64001 | | Technica | 50 Ah | 450 A | T1 | B13 | 207X175X190 | |
| 64002 | | Technica | 62 Ah | 540 A | T1 | B13 | 242X175X190 | |
| 64003 | | Technica | 74 Ah | 680 A | T1 | B13 | 278X175X190 | |
| 69590 | | Technica | 95 Ah | 800 A | T1 | B13 | 353X175X190 | |
| 73435 | | Technica | 95 Ah | 760 A | T1 | Korean B1 | 306X173X222 | |
| 64004 | | Technica | 100 Ah | 720 A | T1 | B13 | 315x175x205 | |
| 85594 | | Heavy Profes- sional | 110 Ah | 750 A | T1 | B1 | 349X175X235 | |
| 64005 | | StartPRO | 140 Ah | 800 A | T1 | B3 | 510X175X225 | |
| 64006 | | Heavy Profes- sional | 140 Ah | 900 A | T1 | B1 | 508X178X205 | |

| Skü | img. | Linea / Line | Capacità batteria / Battery capacity | Spunto / Cue | Terminali / Terminals | Fissaggio / Fastening | Dimensioni / Dimensions | Polarità positiva / Positive polarity |
|-------|------|--------------------|--------------------------------------|--------------|-----------------------|-----------------------|-------------------------|---------------------------------------|
| 64009 | | Heavy Professional | 180 Ah | 1000 A | T1 | B3 | 510X218X225 | |
| 85596 | | Heavy Professional | 180 Ah | 1000 A | T1 | B0 | 513X223X223 | |

BATTERIE YUASA

YUASA BATTERIES
BATTERIES YUASA
YUASA-BATTERIEN
BATERÍAS YUASA

| Skü | img. | Linea / Line | Capacità batteria / Battery capacity | Spunto / Cue | Terminali / Terminals | Fissaggio / Fastening | Dimensioni (mm) / Dimensions (mm) | Polarità positiva / Positive polarity |
|---------|------|--------------|--------------------------------------|--------------|-----------------------|-----------------------|-----------------------------------|---------------------------------------|
| 68621 | | Giardinaggio | 30 Ah | 330 A | T4 | N | 194x126x183 | |
| 68621SX | | Giardinaggio | 30 Ah | 330 A | T4 | N | 194x126x183 | |
| 68623 | | Automotive | 45 Ah | 440 A | T1 | B13 | 207x175x175 | |

BATTERIA OPTIMA

OPTIMA BATTERIES
BATTERIES OPTIMA
OPTIMA BATTERIEN
BATERÍAS OPTIMA

| Skü | img. | Linea / Line | Capacità batteria / Battery capacity | Spunto / Cue | Terminali / Terminals | Fissaggio / Fastening | Dimensioni (mm) / Dimensions (mm) | Polarità positiva / Positive polarity |
|-------|------|--------------|--------------------------------------|--------------|-----------------------|-----------------------|-----------------------------------|---------------------------------------|
| 64531 | | Red Top | 50 Ah | 815 A | T1 | B00 | 254x175x200 | |
| 64532 | | Red Top | 50 Ah | 815 A | T1 | B00 | 254x175x200 | |

BOX BATTERIE

 BATTERY BOX
 BOÎTE À BATTERIE
 BATTERIEKASTEN
 CAJA DE BATERÍA

| Skü | Pos. | Dimensioni / Dimensions |
|-------|-------|---|
| 65004 | 1 / 1 | esterne 34x24,5x27cm e interne 26x18x20 cm / external: 34 x 24.5 x 27 cm; internal: 26 x 18 x 20 cm. |
| 65005 | 2 / 2 | esterne 44x24,5x27 cm e interne 35x18x20 cm / external: 44 x 24.5 x 27 cm; internal: 35 x 18 x 20 cm. |

PINZE PORTA CORRENTE

 BATTERY CLAMPS
 PINCES CÂBLE DE DÉMARRAGE
 STARTERKABELZANGE
 PINZAS DE CABLE DE ARRANQUE

| Skü | Intensità di corrente / Current intensity | Sezione / Section | Note / Notes |
|-------|---|------------------------|--------------|
| 00388 | 90 A | 10÷25 mm ² | |
| 00399 | 120 A | 10÷35 mm ² | |
| 00431 | 200 A | 10÷35 mm ² | |
| 00432 | 300 A | 10÷35 mm ² | |
| 63116 | 50 A | Max 15 mm ² | |
| 63724 | 1000 A | 35-70 mm ² | |

I manici delle pinze, rivestiti in PVC, garantiscono un perfetto isolamento. / The clamp handles, coated in PVC, ensure perfect insulation.

CAVI AVVIAMENTO OSRAM

OSRAM JUMP LEADS
CÂBLES DE DÉMARRAGE OSRAM
OSRAM STARHILFEKABEL
CABLES DE ARRANQUE OSRAM



| Skü | Brand / Brand | Tensione nominale / Rated voltage | Lunghezza / Length | Sezione / Section | Intensità di corrente / Current intensity |
|-------|---------------|-----------------------------------|--------------------|--------------------|---|
| 65972 | Osram | 12-24 V | 3 m | 16 mm ² | 300 A |
| 65974 | Osram | 12-24 V | 3,50 m | 35 mm ² | 900 A |

CAVI AVVIAMENTO E PINZE

JUMP LEADS SET AND BATTERY CLAMPS
KIT CÂBLES DE DÉMARRAGE ET PINCES CÂBLE DE DÉMARRAGE
STARHILFEKABELSATZ UND STARTERKABELZANGE
JUEGO CABLES ARRANQUE Y PINZAS DE CABLE DE ARRANQUE

| Skü | Tensione nominale / Rated voltage | Sezione / Section | Intensità di corrente / Current intensity | Lunghezza / Length | Materiali / Material | Note / Notes |
|-------|-----------------------------------|--------------------|---|--------------------|----------------------|--------------------------------|
| 00376 | 12-24 V | 35 mm ² | 400 A | 3,50 m | Rame / Copper | |
| 00443 | 12-24 V | 25 mm ² | 120 A | 2,50 m | Rame / Copper | |
| 00937 | 12-24 V | 35 mm ² | 400 A | 3,50 m | Rame / Copper | in valigetta / In plastic case |
| 00938 | 12-24 V | 50 mm ² | 500 A | 5 m | Rame / Copper | In valigetta / In plastic case |

MORSETTI BATTERIA TIPO CANOTTO

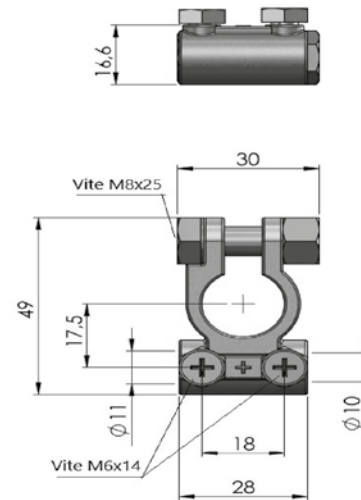
 BATTERY TERMINALS
 COSSES DE BATTERIE
 BATTERIEKLEMME
 BORNES DE BATERIA

Articoli a ricambio

| | | | |
|--|--------------|----------------------------------|-------|
| | 00709 | Cappuccio coprimorsetto positivo | 00456 |
| | 09424 | Cappuccio coprimorsetto negativo | 00457 |

| Skü | Modello / Model | Polarità / Polarity | Sezione / Section | Materiali / Material |
|--------------|-----------------|---------------------|-----------------------|----------------------|
| 00456 | Canotto / Tube | Positivo / Positive | 25~35 mm ² | Ottone / Brass |
| 00457 | Canotto / Tube | Negativo / Negative | 25~35 mm ² | Ottone / Brass |

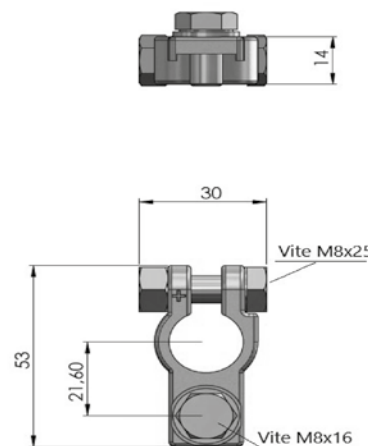
MORSETTI BATTERIA CON BULLONE

 BATTERY TERMINALS WITH BOLT
 COSSES DE BATTERIE AVEC BOULON
 BATTERIEKLEMME MIT SCHRAUBE
 BORNES DE BATERIA CON TORNILLO

Articoli a ricambio



| | | | |
|--|--------------|-------------------------------------|--|
| | 62459 | Cappuccio di protezione in pvc nero | |
|--|--------------|-------------------------------------|--|

| Skü | Modello / Model | Polarità / Polarity | Sezione / Section | Materiali / Material |
|--------------|------------------------|---------------------|-------------------------|----------------------|
| 19006 | Bullone M8 / M8 bolt | Positivo / Positive | 16 ~ 70 mm ² | Ottone / Brass |
| 19007 | Bullone M8 / M8 bolt | Negativo / Negative | 16 ~ 70 mm ² | Ottone / Brass |
| 19008 | Bullone M10 / M10 bolt | Positivo / Positive | 16 ~ 70 mm ² | Ottone / Brass |
| 19009 | Bullone M10 / M10 bolt | Negativo / Negative | 16 ~ 70 mm ² | Ottone / Brass |
| 19010 | Bullone M12 / M12 bolt | Positivo / Positive | 16 ~ 70 mm ² | Ottone / Brass |
| 19011 | Bullone M12 / M12 bolt | Negativo / Negative | 16 ~ 70 mm ² | Ottone / Brass |

MORSETTI BATTERIA A GRAFFARE

BATTERY TERMINALS
 COSES DE BATTERIE
 BATTERIEKLEMME
 BORNES DE BATERIA

**Articoli a ricambio**

| | | | |
|---|-----------------|--|-------|
|  | 00709 | Cappuccio coprimorsetto positivo | 00456 |
|  | 09424 | Cappuccio coprimorsetto negativo | 00457 |
|  | M21027.R | Cappuccio coprimorsetto sx positivo in PVC rosso | |

| Skù | Modello / Model | Polarità / Polarity | Sezione / Section | Materiali / Material |
|--------------|--|---------------------|-----------------------|----------------------|
| 62182 | Fissaggio a graffare / Spring clamp terminal | Positivo / Positive | 16~25 mm ² | Piombo / Lead |
| 62183 | Fissaggio a graffare / Spring clamp terminal | Negativo / Negative | 16~25 mm ² | Piombo / Lead |
| 62188 | Fissaggio a graffare / Spring clamp terminal | Positivo / Positive | 35~50 mm ² | Piombo / Lead |
| 62189 | Fissaggio a graffare / Spring clamp terminal | Negativo / Negative | 35~50 mm ² | Piombo / Lead |
| 62191 | Fissaggio a graffare / Spring clamp terminal | Positivo / Positive | 70 mm ² | Piombo / Lead |
| 62192 | Fissaggio a graffare / Spring clamp terminal | Negativo / Negative | 70 mm ² | Piombo / Lead |

MORSETTI BATTERIA CON DADO A FARFALLA

BATTERY TERMINALS WITH WING NUT
 COSES DE BATTERIE AVEC ÉCROU À OREILLES
 BATTERIEKLEMME MIT FLÜGELMUTTER
 BORNES DE BATERIA CON TUERCA DE MARIPOSA

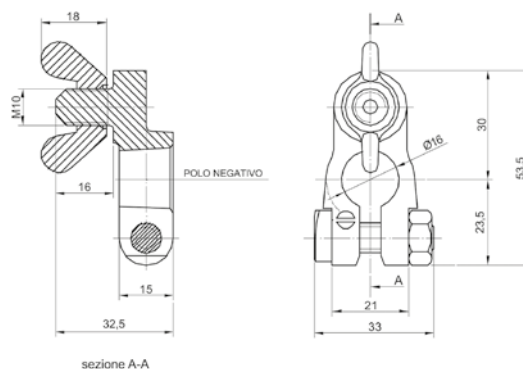
**Articoli a ricambio**

| | | | |
|---|--------------|-------------------------------------|--|
|  | 62459 | Cappuccio di protezione in pvc nero | |
|---|--------------|-------------------------------------|--|

| Skù | Modello / Model | Polarità / Polarity | Sezione / Section | Materiali / Material |
|--------------|-----------------------|---------------------|-------------------|----------------------|
| 62467 | A farfalla / Wing nut | Negativo / Negative | M10 | Ottone / Brass |
| 62468 | A farfalla / Wing nut | Positivo / Positive | M10 | Ottone / Brass |

MORSETTO BATTERIA DOPPIO

BATTERY TERMINAL DOUBLE
 COSES DE BATTERIE DOUBLE
 BATTERIE-DOPPELKLEMME
 BORNES DE BATERIA DOBLE

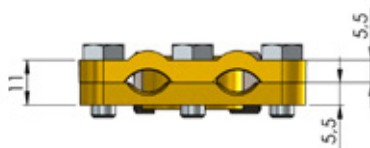

| Skü | Modello / Model | Polarità / Polarity | Sezione / Section | Materiali / Material |
|--------------|--|---------------------|--|----------------------|
| 19012 | Piastrina doppia / With double clamp plate | Positivo / Positive | Fino a 50 mm ² / Max 50 mm ² | Ottone / Brass |
| 19013 | Piastrina doppia / With double clamp plate | Negativo / Negative | Fino a 50 mm / Max 50 mm | Ottone / Brass |

MORSETTO BATTERIA TIPO ALFA RINFORZATO

BATTERY TERMINALS
 COSES DE BATTERIE
 BATTERIEKLEMME
 BORNES DE BATERIA

1

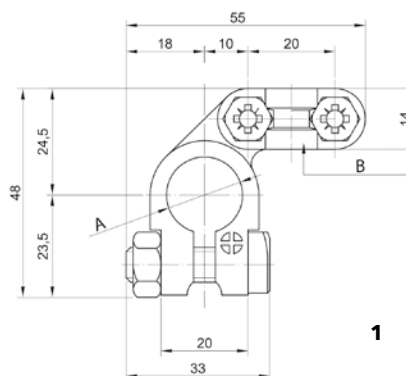
2

1

| Skü | Pos. | Modello / Model | Polarità / Polarity | Sezione / Section | Materiali / Material |
|--------------|-------|--|---|-----------------------|----------------------|
| 00725 | 1 / 1 | Alfa rinforzato / Reinforced Alfa type | Positivo / Positive | 25~50 mm ² | Ottone / Brass |
| 00727 | 1 / 1 | Alfa rinforzato / Reinforced Alfa type | Negativo / Negative | 25~50 mm ² | Ottone / Brass |
| 60128 | 2 / 1 | Alfa rinforzato / Reinforced Alfa type | Positivo e negativo / Positive and negative | 25~50 mm ² | Ottone / Brass |

MORSETTI BATTERIA TIPO ALFA PESANTE

BATTERY TERMINALS
 COSES DE BATTERIE
 BATTERIEKLEMME
 BORNES DE BATERIA

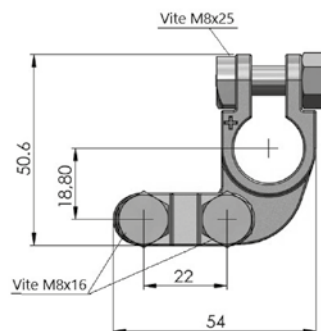
1

2

1
Articoli a ricambio

M21239 Coprimorsetto rosso

M21240 Coprimorsetto nero

| Skü | Pos. | Modello / Model | Polarità / Polarity | Sezione / Section | Materiali / Material |
|--------------|-------|--------------------------------|---|--|----------------------|
| 19003 | 1 / 1 | Alfa pesante / Heavy-duty Alfa | Positivo / Positive | Fino a 120 mm ² / Max 120 mm ² | Ottone / Brass |
| 19004 | 1 / 1 | Alfa pesante / Heavy-duty Alfa | Negativo / Negative | Fino a 120 mm ² / Max 120 mm ² | Ottone / Brass |
| 55839 | 2 / 1 | Alfa pesante / Heavy-duty Alfa | Positivo e negativo / Positive and negative | Fino a 120 mm ² / Max 120 mm ² | Ottone / Brass |

MORSETTI BATTERIA A PIASTRINA

BATTERY TERMINALS WITH PLATE
 BORNES DE BATTERIE À PLAQUE
 BATTERIEANSCHLÜSSE MIT PLÄTTCHEN
 TERMINALES DE BATERÍA CON PLACA

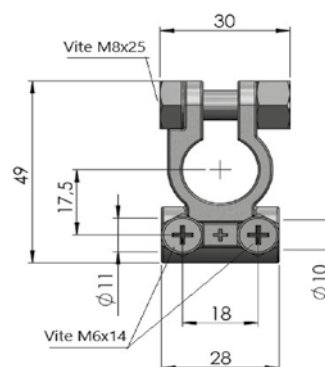
**Articoli a ricambio**

62459 Cappuccio di protezione in pvc nero

| Sku | Modello / Model | Polarità / Polarity | Sezione / Section | Materiali / Material |
|--------------|--------------------------|---------------------|--|----------------------|
| 55370 | A piastrina / With plate | Positivo / Positive | Fino a 50 mm ² / Max 50 mm ² | Ottone / Brass |
| 55371 | A piastrina / With plate | Negativo / Negative | Fino a 50 mm ² / Max 50 mm ² | Ottone / Brass |

MORSETTI BATTERIA TIPO PESANTE A DOPPIA PIASTRINA

HEAVY-DUTY BATTERY TERMINALS WITH DOUBLE PLATE
 BORNES DE BATTERIE TYPE LOURDES À DOUBLE PLAQUE
 SCHWERLAST-BATTERIEANSCHLÜSSE MIT DOPPELTER PLATTE
 TERMINALES DE BATERÍA TIPO PESADOS CON DOBLE PLACA

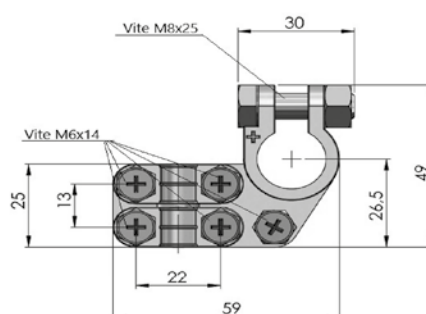
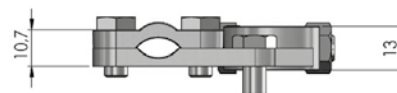

| Sku | Modello / Model | Polarità / Polarity | Sezione / Section | Materiali / Material |
|--------------|--|---------------------|-----------------------|----------------------|
| 55388 | A doppia piastrina laterale / Side-entry double plate battery terminal | Positivo / Positive | 50~70 mm ² | Ottone / Brass |
| 55389 | A doppia piastrina laterale / Side-entry double plate battery terminal | Negativo / Negative | 50~70 mm ² | Ottone / Brass |

MORSETTO BATTERIA TIPO PESANTE CON VITI DIAMETRO 8/10/8 MM

HEAVY-DUTY BATTERY TERMINAL WITH SCREWS 8/10/8 MM DIAMETER
 BORNE DE BATTERIE TYPE LOURD AVEC VIS DIAMÈTRE 8/10/8 MM
 SCHWERLAST-BATTERIEANSCHLUSS MIT SCHRAUBEN DURCHMESSER 8/10/8 MM
 TERMINAL DE BATERÍA TIPO PESADO CON TORNILLOS DIÁMETRO 8/10/8 MM

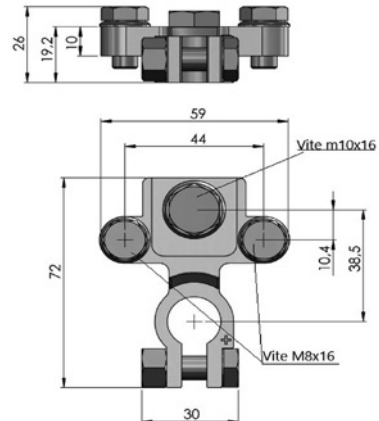

| Skü | Modello / Model | Polarità / Polarity | Materiali / Material |
|-------|--|---------------------|----------------------|
| 55390 | Con viti Ø 8/10/8 mm / With screws Ø 8/10/8 mm | Positivo / Positive | Ottone / Brass |

SET MORSETTI SGANCIO RAPIDO



BATTERY QUICK RELEASE TERMINALS
 KIT DE COSSES DE BATTERIE
 SCHNELLPOLKLEMMENSATZ
 KIT DE BORNES DE BATERÍA



| Skü | Modello / Model | Polarità / Polarity | Sezione / Section | Materiali / Material |
|-------|--|---|-----------------------|------------------------------------|
| 60149 | Sgancio rapido / Quick release battery terminals | Positivo e negativo / Positive & negative | 16~50 mm ² | Ottone stagnato / Tin-plated brass |

BATTERY JUMPER TERMIAL POSITIVO E NEGATIVO

REMOTE BATTERY JUMPER TERMINALS
 COSSES DE DÉMARRAGE BATTERIE À DISTANCE
 EXTERNER STARHILFEANSCHLUSS
 BORNES DE ARRANQUE DE BATERÍA REMOTO

| Skü | Modello / Model | Polarità / Polarity | Dimensioni / Dimensions | Materiali / Material |
|-----------------|---|---------------------|--------------------------|----------------------|
| M21308.N |  Battery jumper negativo colore nero / Black negative battery jumper | Negativo / Negative | Dado 3/8-16 / 3/8-16 nut | Ottone / Brass |
| M21308.P |  Battery jumper positivo colore rosso / Red positive battery jumper | Positivo / Positive | Dado 3/8-16 / 3/8-16 nut | Ottone / Brass |

CAVI BATTERIA

BATTERY CABLES
 CÄBLES DE BATTERIE
 BATTERIEKABEL
 CABLE DE BATERÍA

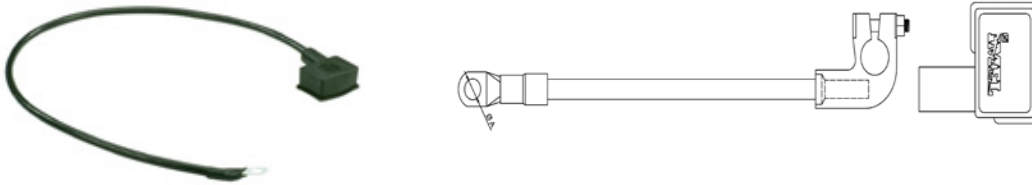

| Skü | Sezione / Section | Lunghezza / Length | Diametro / Diameter | Polarità / Polarity |
|-------------------|--------------------|--------------------|--|------------------------------|
| CF.0500.BD | 35 mm ² | 50 cm | Capocorda a occhiello ø 10.5 mm / Ring terminal with Ø 10.5 mm stud hole | Positivo / Positive terminal |
| CG.0500.AD | 50 mm ² | 50 cm | Capocorda a occhiello ø 10.5 mm / Ring terminal with Ø 10.5 mm stud hole | Negativa / Negative terminal |
| CG.0600.AD | 50 mm ² | 60 cm | Capocorda a occhiello ø 10.5 mm / Ring terminal with Ø 10.5 mm stud hole | Negativa / Negative terminal |
| CG.1500.AD | 50 mm ² | 1,50 m | Capocorda a occhiello ø 10.5 mm / Ring terminal with Ø 10.5 mm stud hole | Negativa / Negative terminal |
| CG.1500.BD | 50 mm ² | 1,50 m | Capocorda a occhiello ø 10.5 mm / Ring terminal with Ø 10.5 mm stud hole | Positivo / Positive terminal |
| CG.1700.BD | 50 mm ² | 1,70 m | Capocorda a occhiello ø 10.5 mm / Ring terminal with Ø 10.5 mm stud hole | Positivo / Positive terminal |
| CG.1800.BD | 50 mm ² | 1,80 m | Capocorda a occhiello ø 10.5 mm / Ring terminal with Ø 10.5 mm stud hole | Positivo / Positive terminal |

CAVI BATTERIA

BATTERY CABLES
 CÄBLES DE BATTERIE
 BATTERIEKABEL
 CABLE DE BATERÍA



| Skü | Sezione / Section | Lunghezza / Length | Diametro / Diameter |
|-------------------|--------------------|--------------------|--|
| CF.0500.DD | 35 mm ² | 50 cm | Capocorda a occhiello ø 10,5 mm / Ring terminal with Ø 10.5 mm stud hole |
| CG.0500.DD | 50 mm ² | 50 cm | Capocorda a occhiello ø 10,5 mm / Ring terminal with Ø 10.5 mm stud hole |

CAVO PER CAVI BATTERIA

BATTERY CABLE
CÂBLE DE BATTERIE
BATTERIEKABEL
CABLE DE BATERÍA



| Skü | Tensione nominale / Rated voltage | Sezione / Section | Diametro esterno / Outer diameter | Note / Notes | Confezionamento / Packaging | Contenuto / Content | Temperatura di esercizio / Operating temperature |
|-------|--------------------------------------|----------------------|--------------------------------------|---|--------------------------------|------------------------|---|
| 62477 | 450/750V | 1x10mm ² | 7,6 mm | PVC nero e rame flessibile rosso / Black PVC & flexible red copper | matassa / coil | 25 m | -5°C/+70°C |
| 17445 | 450/750V | 1X16mm ² | 9,2 mm | PVC nero e rame flessibile rosso / Black PVC & flexible red copper | matassa / coil | 25 m | -5°C/+70°C |
| 62478 | 450/750V | 1x25mm ² | 10,5 mm | PVC nero e rame flessibile rosso / Black PVC & flexible red copper | matassa / coil | 25 m | -5°C/+70°C |
| 17446 | 450/750V | 1X35mm ² | 12,0 mm | PVC nero e rame flessibile rosso / Black PVC & flexible red copper | matassa / coil | 25 m | -5°C/+70°C |
| 17447 | 450/750V | 1x50mm ² | 13,9 mm | PVC nero e rame flessibile rosso / Black PVC & flexible red copper | matassa / coil | 25 m | -5°C/+70°C |
| 62479 | 450/750V | 1x70mm ² | 15,8 mm | PVC nero e rame flessibile rosso / Black PVC & flexible red copper | Bobina/ Reel | 25 m | -5°C/+70°C |

TRECCE DI MASSA

EARTH STRAP 2 HOLE
TRESSE DE MASSE 2 PERCEMENT
MASSEBAND 2 BOHRUNG
CABLE DE MASA TRENZADO



| Skü | Modello / Model | Lunghezza / Length | Sezione / Section | Diametro foro / Hole diameter | Materiali / Material |
|-------|-------------------------|--------------------|--------------------|-------------------------------|----------------------|
| 00857 | Due occhielli / 2 holes | 30 cm | 25 mm ² | 10,5 mm | Rame/ Copper |
| 26108 | Due occhielli / 2 holes | 50 cm | 50 mm ² | 12,5 mm | Rame/ Copper |
| 61534 | Due occhielli / 2 holes | 32 cm | 50 mm ² | 12,5 mm | Rame/ Copper |
| 61549 | Due occhielli / 2 holes | 40 cm | 16 mm ² | 10,5 mm | Rame/ Copper |

TRECCE DI MASSA CON MORSETTO

EARTH STRAP WITH INTEGRATED TERMINAL
TRESSE DE MASSE AVEC COSSE DE BATTERIE
MASSEBAND MIT BATTERIEKLEMMEN
CABLE DE MASA TRENZADO CON BORNE DE BATERÍA



| Skü | Modello / Model | Lunghezza / Length | Sezione / Section | Diametro foro / Hole diameter | Polarità / Polarity |
|-------|--|--------------------|--------------------|-------------------------------|--|
| 00858 | Morsetto e occhiello / With clamp and eyelet | 40 cm | 25 mm ² | 10,5 mm | Morsetto negativo/ Negative terminal clamp |
| 19005 | Morsetto e occhiello / With clamp and eyelet | 50 cm | 35 mm ² | 12,5 mm | Morsetto negativo/ Negative terminal clamp |
| 26109 | Morsetto e occhiello / With clamp and eyelet | 50 cm | 50 mm ² | 12,5 mm | Morsetto negativo/ Negative terminal clamp |

CARICA BATTERIE AUTOMATICO E MANTENITORE

AUTOMATIC BATTERY CHARGERS WITH PROGRAM FOR CHARGE CONSERVATION SM C8
 CHARGEUR ET MAINTENEUR DE BATTERIE SM C8
 AUTOMATISCHER BATTERIELADEGERÄT UND WARTUNGSGERÄT
 CARGADORES DE BATERÍA AUTOMÁTICOS CON PROGRAMA PARA CONSERVACIÓN DE CARGA



Carica batterie automatici, con programma per la carica di mantenimento (carica ad impulsi) / Automatic battery chargers with program for charge conservation (pulse recharge)

| Skü | Tensione nominale / Rated voltage | Potenza nominale / Rated power | Corrente di carica media / Average charging current | Capacità batteria / Battery capacity | Altezza / Height | Larghezza / Width | Lunghezza / Length | Note / Notes |
|-------|-----------------------------------|--------------------------------|---|--------------------------------------|------------------|-------------------|--------------------|--------------|
| 63696 | IN 230 V-50Hz OUT 12V | 14. W | 0,80 A | 35 Ah | 15,70 cm | 6,40 cm | 3 cm | DECA Sm C8 |

CARICABATTERIA AUTOMATICO CON CONTROLLO ELETTRONICO

FULLY AUTOMATIC BATTERY CHARGERS DECA FL2213D
 CHARGEUR AUTOMATIQUE DECA FL2213D
 VOLLAUTOMATISCHE BATTERIELADEGERÄTE
 CARGADORES DE BATERÍA TOTALMENTE AUTOMÁTICOS



Tipi di batterie ricaricabili: al Pb Wet con e senza manutenzione, Pb AGM, Gel. Protezione contro le inversioni di polarità. Protezione contro i corto circuiti alle pinze. / Rechargeable battery types Pb WET maintenance free, Pb AGM, Gel. Protection against polarity reversal. Protection against short-circuiting.

| Skü | Tensione nominale / Rated voltage | Potenza nominale / Rated power | Corrente di carica efficace / Effective charging current | Intensità di corrente / Current intensity | Corrente di carica media / Average charging current | Capacità batteria / Battery capacity | Programmi di carica / Charging programmes | Altezza / Height | Larghezza / Width | Lunghezza / Length | Note / Notes |
|-------|-----------------------------------|--------------------------------|--|---|---|--------------------------------------|---|------------------|-------------------|--------------------|--------------|
| 83950 | IN 230 V-50Hz OUT 6V- 12V-24V | 530W | 22 A | 3,0 - 6,5 - 13,0A | 35 A | 260 Ah | 3 | 12,65 cm | 31,20 cm | 17,25 cm | DECA FL2213D |

CARICA BATTERIA COMPATTO PORTATILE

PORTABLE BATTERY

CHARGEUR DE BATTERIES DÉMARRAGE RAPIDE POUR ACCUMULATEURS AU PLOMBE/ELECTROLYTE

TRAGBARES LADEGERÄT

CARGADOR DE BATERIA



Tipi di batterie ricaricabili: al Pb Wet con e senza manutenzione, Pb AGM. Protezione contro le inversioni di polarità. Protezione contro i corto circuiti alle pinze. / Rechargeable battery types Pb WET maintenance free, Pb AGM. Protection against polarity reversal. Protection against short-circuiting

| Skü | Tensione nominale / Rated voltage | Potenza nominale / Rated power | Corrente di carica efficace / Effective charging current | Intensità di corrente / Current intensity | Corrente di carica media / Average charging current | Potenza nominale / Rated power | Capacità batteria / Battery capacity | Programmi di carica / Charging programmes | Altezza / Height | Larghezza / Width | Lunghezza / Length | Note / Notes |
|-------|-----------------------------------|--------------------------------|--|---|---|--------------------------------|--------------------------------------|---|------------------|-------------------|--------------------|--------------|
| 19191 | IN 230 V-50Hz OUT 6V-12V | 50W | 4 A | 2,5/4,0 A | 2,50 A | 50W | 60 Ah | 1 | 95 mm | 22,50 cm | 16 cm | DECA MACH214 |

CARICA BATTERIA COMPATTO PORTATILE

PORTABLE BATTERY CHARGER

CHARGEUR DE BATTERIE

TRAGBARES LADEGERÄT

CARGADOR DE BATERIA



Tipi di batterie ricaricabili: al Pb Wet con e senza manutenzione, Pb AGM. Protezione contro le inversioni di polarità. Protezione contro i corto circuiti alle pinze. / Rechargeable battery types Pb WET maintenance free, Pb AGM. Protection against polarity reversal. Protection against short-circuiting.

| Skü | Tensione nominale / Rated voltage | Potenza nominale / Rated power | Corrente di carica efficace / Effective charging current | Intensità di corrente / Current intensity | Corrente di carica media / Average charging current | Capacità batteria / Battery capacity | Programmi di carica / Charging programmes | Altezza / Height | Larghezza / Width | Lunghezza / Length | Note / Notes |
|-------|-----------------------------------|--------------------------------|--|---|---|--------------------------------------|---|------------------|-------------------|--------------------|---------------|
| 36902 | IN 230 V-50Hz OUT 12V | 80 W | 6 A | 4/6 A | 4 A | 90 Ah | 1 | 95 mm | 22,50 cm | 16 cm | DECA MATIC116 |

CARICABATTERIE PER TUTTI I TIPI DI ACCUMULATORI AL PIOMBO/ELETTROLITO

BATTERY CHARGER SUITABLE FOR LEAD ELECTROLYTE ACCUMULATORS
 BATTERY CHARGER SUITABLE FOR ACCUMULATEURS AU PLOMBE/ELECTROLYTE
 BATTERIELADEGERÄT GEEIGNET FÜR BLEI-ELEKTROLYT-AKKUMULATOREN
 CARGADOR DE BATERIA PARA LA CARGA DE ACUMULADOR DE PLOMO ELECTROLITO



1



2

Regolazione della corrente di carica. Protezione termostatica.

Protezione contro i corto circuiti. Protezione contro le inversioni di polarità.

Tipi di batterie ricaricabili: al Pb Wet con e senza manutenzione, Pb AGM / Adjustment of charging current. Thermostatic protection. Protection against short-circuiting.

Protection against polarity reversal. Rechargeable battery types Pb WET maintenance free, Pb AGM

| Skù | Pos. | Tensione nominale / Rated voltage | Potenza nominale / Rated power | Corrente di carica efficace / Effective charging current | Intensità di corrente / Current intensity | Corrente di carica media / Average charging current | Capacità batteria / Battery capacity | Programmi di carica / Charging programmes | Altezza / Height | Larghezza / Width | Lunghezza / Length | Note / Notes |
|-------|------|-----------------------------------|--------------------------------|--|---|---|--------------------------------------|---|------------------|-------------------|--------------------|----------------|
| 19192 | 1 | IN 230 V-50Hz OUT 12V-24V | 130 W | 9 A | 6/9 A | 6 A | 140 Ah | 2 | 27 cm | 20 cm | 19 cm | DECA CLASS 12A |
| 19193 | 2 | IN 230 V-50Hz OUT 12V-24V | 600 W | 30 A | 20/30 A | 20 A | 300 Ah | 2 | 27 cm | 20 cm | 19 cm | DECA CLASS 30A |

CARICA BATTERIE CON AVVIAMENTO RAPIDO PER ACCUMULATORI PIOMO/ELETTROLITO

BATTERY CHARGER WITH RAPID STARTER FOR LEAD ACCUMULATORS/ELECTROLYTE AND QUICK BOOSTING
 CHARGEUR DE BATTERIES DÉMARRAGE RAPIDE POUR ACCUMULATEURS AU PLOMBE/ELECTROLYTE
 BATTERIELADEGERÄT MIT SCHNELLSTARTEN ZUM LADEN VON BLEI ELEKTROLYTBATTERIEN
 CARGADOR DE BATERIA CON ARRANQUE RAPIDO PARA LA CARGA DE UN ACUMULADOR DE PLOMO ELECTROLITO



Regolazione della corrente di carica. Protezione termostatica. Protezione contro i corto circuiti.

Protezione contro le inversioni di polarità. /Tipi di batterie ricaricabili: al Pb Wet con e senza manutenzione, Pb AGM. / Adjustment of charging current. Thermostatic protection. Protection against short-circuiting.

Rechargeable battery types Pb WET maintenance free, Pb AGM

| Skù | Tensione nominale / Rated voltage | Potenza nominale / Rated power | Corrente di carica efficace / Effective charging current | Intensità di corrente / Current intensity | Corrente di carica media / Average charging current | Programmi di carica / Charging programmes | Altezza / Height | Larghezza / Width | Lunghezza / Length | Note / Notes |
|-------|-----------------------------------|--------------------------------|--|---|---|---|------------------|-------------------|--------------------|-----------------|
| 19194 | IN 230 V-50Hz OUT 12V-24V | 500-3000W | 20 A | 13/20 A | 13 A | 2 | 16 cm | 34 cm | 30 cm | DECA CLASS 220A |

CARICABATTERIA CON AVVIAMENTO RAPIDO PER ACCUMULATORI AL PIOMBO

BATTERY CHARGER WITH RAPID STARTER FOR LEAD ACCUMULATORS/ELECTROLYTE AND QUICK BOOSTING
 CHARGEUR DE BATTERIES DÉMARRAGE RAPIDE POUR ACCUMULATEURS AU PLOMBE
 BATTERIELADEGERÄT MIT SCHNELLSTARTEN ZUM LADEN VON BLEI ELEKTROLYBATTERIEN
 CARGADOR DE BATERIA CON ARRANQUE RAPIDO PARA LA CARGA DE UN ACUMULADOR DE PLOMO ELECTROLITO

1

2

Regolazione della corrente di carica. Protezione termostatica. Protezione contro i corto circuiti.
 Protezione contro le inversioni di polarità. / Tipi di batterie ricaricabili: al Pb Wet con e senza manutenzione, Pb AGM. /
Adjustment of charging current. Thermostatic protection. Protection against short-circuiting.
Rechargeable battery types Pb WET maintenance free, Pb AGM.

| Skü | Pos. | Tensione nominale / Rated voltage | Potenza nominale / Rated power | Corrente di carica efficace / Effective charging current | Intensità di corrente / Current intensity | Corrente di carica media / Average charging current | Capacità batteria / Battery capacity | Programmi di carica / Charging programmes | Altezza / Height | Larghezza / Width | Lunghezza / Length | Note / Notes |
|-------|------|--------------------------------------|-----------------------------------|---|--|--|---|--|---------------------|----------------------|-----------------------|-----------------|
| 19195 | 1 | IN 230 V-50Hz OUT 12V-24V | 700-3500 W | 14 A | 14/20 A | 20 A | 350 Ah | 2 | 64 cm | 40 cm | 30 cm | DECA CLASS 300E |
| 83804 | 2 | IN 230 V-50Hz OUT 12V-24V | 1300-6000 W | 26 A | 26/40 A | 40 A | 500 Ah | 4 | 40 cm | 30 cm | 64 cm | DECA CLASS 400E |

CARICABATTERIA CON AVVIAMENTO RAPIDO PER ACCUMULATORI AL PIOMBO

BATTERY CHARGER WITH RAPID STARTER FOR CHARGING LEAD ACCUMULATORS AND QUICK BOOSTING
 CHARGEUR DE BATTERIES DÉMARRAGE RAPIDE POUR ACCUMULATEURS AU PLOMBE
 BATTERIELADEGERÄT MIT SCHNELLSTARTEN ZUM LADEN VON BLEI ELEKTROLYBATTERIEN
 CARGADOR DE BAT CLASS B0.5000



Protezione termostatica. Protezione contro i corto circuiti. Protezione contro le inversioni di polarità. Tipi di batterie ricaricabili: al Pb Wet con e senza manutenzione, Pb AGM. /
Overload protection. Protection against short-circuiting. Protection against polarity reversal. Rechargeable battery types Pb WET maintenance free, Pb AGM

| Skü | Tensione nominale / Rated voltage | Potenza nominale / Rated power | Corrente di carica efficace / Effective charging current | Intensità di corrente / Current intensity | Corrente di carica media / Average charging current | Capacità batteria / Battery capacity | Programmi di carica / Charging programmes | Altezza / Height | Larghezza / Width | Lunghezza / Length | Note / Notes |
|-------|--------------------------------------|-----------------------------------|---|--|--|---|--|---------------------|----------------------|-----------------------|-----------------|
| 38802 | IN 230 V-50Hz OUT 12V | 2500-11.000 W | 105 A | 70/105 A | 70 A | 800 Ah | 4 | 75 cm | 47 cm | 32 cm | DECA CLASS 5000 |

CARICABATTERIA CON CONTROLLO PICCHI DI TENSIONE

BATTERY CHARGER WITH VOLTAGE CONTROL

CHARGEUR DE BATTERIE AVEC CONTRÔLE DE LA TENSION

BATTERIELADEGERÄT MIT SPANNUNGSREGELUNG

CARGADOR DE BATERÍA CON CONTROL DE VOLTAJE



Adatto alla ricarica di batterie al piombo: WET con e senza manutenzione, AGM, GEL, Ca/Ca SAFE CHARGE & BOOST: il sistema protegge l'elettronica montata nei veicoli da eventuali interferenze e sovra-tensioni che potrebbero generarsi durante la carica o durante l'avviamento rapido. FLOATING: può essere tenuto collegato alla batteria per un tempo prolungato. Mantiene la batteria pronta all'uso. REGOLAZIONE FINE DELLA CORRENTE: consente di caricare in maniera ottimale le batterie di tutte le capacità (Ah). Carica con timer, comando a distanza per l'avviamento, voltmetro/amperometro digitale, protezione termostatica a riarmo automatico, protezione contro le inversioni di polarità e corto circuiti, pinze heavy duty. / Suitable for charging lead batteries: WET serviceable and maintenance free, AGM, GEL, Ca/Ca SEFE CHARGE & BOOST: the system protects the electronic components on the vehicle against interference and overvoltage that may be created at the charging or quick starting procedures. FLOATING: can remain connected to the battery for a long time. Batteries are ready to use all times. CONTINUOUSLY ADJUSTABLE CHARGE CURRENT: lets you charge optimally batteries of all capacities (Ah). Charging with timer, boosting remote control, digital voltmeter/ammeter, overload protection with automatic reset, inversion of polarity and short circuits protection, heavy duty clamps

| Skù | Tensione nominale / Rated voltage | Potenza nominale / Rated power | Corrente di carica efficace / Effective charging current | Intensità di corrente / Current intensity | Corrente di carica media / Average charging current | Capacità batteria / Battery capacity | Programmi di carica / Charging programmes | Altezza / Height | Larghezza / Width | Lunghezza / Length | Note / Notes |
|-------|-----------------------------------|--------------------------------|--|---|---|--------------------------------------|---|------------------|-------------------|--------------------|---------------|
| 85491 | IN 230 V-50Hz OUT 12V-24V | 1700-16.800 W | 80 A | 50 A | 50 A | 1000 Ah | Stepless | 90,30 cm | 39 cm | 28 cm | DECA SC80/900 |

AVVIATORE EMERGENZA E FONTE DI ENERGIA PORTATILE "START BOOSTER"

EMERGENCY STARTER AND PORTABLE ENERGY SOURCE "START BOOSTER"

DEMARRÉUR EMERGENCE ET SOURCE D'ÉNERGIE PORTABLE "START BOOSTER"

NOTSTROMAGGREGAT START BOOSTER

ARRANCADOR DE EMERGENCIA Y FUENTE DE ENERGÍA PORTÁTIL "START BOOSTER"



1



2



Scocca in ABS e circuito di protezione dai picchi di corrente. Trasformatore automatico da 220V e cavo ricarica accendisigari in dotazione. / ABS casing and surge protection circuit. Automatic 220V transformer and cigarette lighter charging cable included.

| Skù | Pos. | Descrizione / Description | Tensione nominale / Rated voltage | Intensità di corrente / Current intensity | Note / Notes |
|-------|------|--|-----------------------------------|---|--|
| 96821 | 1 | Start booster 12V 1700 A. Compatto e versatile con batteria AGM. Scocca in ABS e circuito di protezione dai picchi. Trasformatore automatico da 220 e cavo ricarica accendisigari / Start booster 12V 1700 A Compact and versatile with AGM battery. ABS shell and 220 automatic transformer protection circuit and cigar lighter charging cable | 12 V | 1700 A | Monta 1 batteria 12V Omologato CE. Scocca ABS. Pinze isolate. Cavo di ricarica 12V. Caricatore automatico. Pinze isolate, con ganasce non metalliche "anti-scintillio". Fornito di serie con trasformatore (230V automatico) e cavo accendisigari. |
| 96822 | 2 | Avviatore emergenza 12V 2500 A. Scocca ABS. Indicatore di carica a LED. Cavi in puro rame 25mm ² . Batteria AGM puro Pb / Emergency starter 12V 2500 A. ABS casing. LED charge indicator. Pure copper cables 25mm ² . Pure AGM battery Pb | 12 V | 2500 A | Monta 1 batteria 12V Omologato CE. Scocca ABS. Pinze isolate. Cavo di ricarica 12V. Caricatore automatico. Pinze isolate, con ganasce non metalliche "anti-scintillio". Fornito di serie con trasformatore (230V automatico) e cavo accendisigari. |

AVVIATORE EMERGENZA E FONTE DI ENERGIA PORTATILE "START TRUCK"

EMERGENCY STARTER AND PORTABLE ENERGY SOURCE "START TRUCK"
 DEMARREUR EMERGENCE ET SOURCED'ENERGIEPORTABLE "START TRUCK"
 NOTSTROMAGGREGAT "START TRUCK"
 ARRANCADOR DE EMERGENCIA Y FUENTE DE ENERGIA PORT

1

2

E' coperto da brevetto, conforme alle norme di sicurezza ed ecologiche. E' completamente ricaricabile, sia tramite un trasformatore, direttamente dalla rete (220 V), sia tramite un cavo a doppia spina accendisigari, direttamente dal mezzo (12 V), è dotato di batterie speciali ,con tecnologia al piombo. Può essere utilizzato come avviatore di emergenza, tramite i cavi e le pinze in dotazione e come fonte di energia portatile, prelevando tensione 12V dalla presa tipo accendisigari del "START TRUCK" (la stessa che viene utilizzata per effettuare le ricariche) per il possibile utilizzo di accessori. "START TRUCK" è anche uno strumento indispensabile per sostituire le batterie di recenti mezzi equipaggiati con dispositivi elettronici "di memoria" (es. centraline, sistemi di allarme, radio con memoria...). Infatti se "START TRUCK" viene inserito tramite la solita spina accendisigari alla relativa presa esistente sul mezzo, in condizioni di "quadro inserito", permette di mantenere inalterate tutte queste memorie e di non perderle. Per qualsiasi applicazione a 12V, settore Agricolo & Industriale. / *It is patented and produced according to safety and environmental norms. It is rechargeable both from the 220 V net, by using a transformer, and from the vehicle (12 V) by using a cigar lighter cable. Batteries produced with "lead technology" . It can be used as emergency starter by using cables and pincers supplied with the product. "START TRUCK" can be also used replace batteries of recent vehicles equipped with memory electronic devices (for example alarm system, radio). As a matter of facts if START TRUCK is inserted in the cigar lighter of the vehicle while the instrument panel is on, it allows to maintain memories of the devices.*

| Skü | Pos. | Descrizione / Description | Tensione nominale / Rated voltage | Intensità di corrente / Current intensity | Peso / Weight |
|--------------|------|---|--------------------------------------|--|---------------|
| 35982 | 2 | Start booster 12V 5000A. Monta 2 batterie 12V17AH. Omologato CE.Lunghezza cavi 1mt. Pinze isolate. Cavo di ricarica 12V Caricatore automatico. E' coperto da brevetto, conforme alle norme di sicurezza ed ecologiche. E' completamente ricaricabile, sia tramite un trasformatore, direttamente dalla rete (220 V), sia tramite un cavo a doppia spina accendisigari, direttamente dal mezzo (12 V). Fusibile su pinza + fusibile di scorta + buzzer + Voltmetro digitale. / Equipped with 2 batteries 12 V 17 AH. CE. certificated. Cable length 1 mt. 75. Made in Swiss. Insulated pliers. Recharging cable 12 V. Automatic charger. | 12 V | 5000 A | 18 kg |
| 96823 | 1 | Avviatore Emergenza con commutatore 12/24 5000/2500A, modello a piastre resistenza al calore , Indicatore di carica digitale Pinze 1000A in ottone Doppia batteria AGM Scocca ABS / Emergency starter with switch 12/24 5000/2500A,,heat resistance plate model,Digital charge indicator Pliers 1000A brass Double battery AGM Body ABS | 12/24 V | 5000 / 2500 A | 20 kg |
| 96824 | 1 | Avviatore Emergenza con commutatore 12/24 6400/2200A, modello a piastre resistenza al calore , Indicatore di carica digitale Pinze 1000A in ottone Doppia batteria AGM Scocca ABS / Emergency starter with switch 12/24 6400/2200A,,heat resistance plate model,Digital charge indicator Pliers 1000A brass Double battery AGM Body ABS | 12/24 V | 6400 / 3200 A | 23,50 kg |

TESTER BATTERIA E ALTERNATORE

BATTERY & ALTERNATOR TESTER
 TESTEUR DE BATTERIE ET D'ALTERNATEUR
 BATTERIE- UND LICHTMASCHINE-PRÜFER
 PROBADOR DE BATERÍA Y ALTERNADOR

ZECA

Tester batteria e alternatore a 12 volt sia per le batterie che per l'alternatore. La prova si effettua in soli 15 secondi. La lettura si può eseguire in 6 lingue. Il tester ha il display grande 2x16 ed è retroilluminato a led. Il contenitore è in tecnopolimero, con guscio di protezione soft-touch. L'imballo completo di pratica custodia protettiva E' un prodotto a marchio CE, sicuro e affidabile. La prova viene effettuata a bassa corrente in modo da non danneggiare la centralina, durante l'utilizzo non si generano scintille e non si può mai verificare il surriscaldamento dell'oggetto per la massima sicurezza dell'operatore e del mezzo.

Con il sistema di compensazione della temperatura, un sensore di temperatura integrato permette di adattarsi alla batteria a seconda della temperatura ambiente, a protezione della stessa L'esecuzione del test non scarica la batteria, si può eseguire in qualsiasi situazione. Come test alternatore è adatto per autovetture e autocarri.

Con il tester sono comprese le pinze a doppio contatto il modello con connessione tipo Kelvin.

/ Battery and alternator tester at 12 volts for both batteries and alternators. The test is carried out in just 15 seconds. The reading can be performed in 6 languages. The tester has a large 2x16 display and is LED backlit. The housing is made of technopolymer, with a soft-touch protective shell. The packaging includes a practical protective case. It is a CE-marked product, safe and reliable. The test is performed at low current so as not to damage the control unit; during use, no sparks are generated, and overheating of the object cannot occur, ensuring maximum safety for the operator and the vehicle.

With the temperature compensation system, an integrated temperature sensor allows adaptation to the battery depending on the ambient temperature, protecting it. The test does not discharge the battery and can be performed in any situation. As an alternator test, it is suitable for cars and trucks.

The tester includes double-contact clamps, the model with Kelvin-type connection.

| Sku | Tensione nominale / Rated voltage | Descrizione / Description |
|-------|-----------------------------------|---|
| 84697 | 12 V | tester batteria e alternatore 12V- Durata test 15 sec / battery and alternator tester |

TESTER BATTERIA 6/12V CON STAMPANTE INTEGRATA

BATTERY TESTER WITH EMBEDDED PRINTER
 TESTEUR DE BATTERIE AVEC IMPRIMANTE INTÉGRÉE
 BATTERIETESTER MIT EINGEBAUTEM DRUCKER
 PROBADOR DE BATERÍA CON IMPRESORA INTEGRADA



Tester di batterie professionale con stampante integrata per batterie e sistemi di avviamento/carica 12/24V. Adatto per test rapidi e precisi della batteria, alternatore, motorino di avviamento e massa. Analizza la maggior parte dei modelli di batteria (CCA, BCI, CA, MCA, JIS, DIN, IEC, EN, SAE, GB) fornendo risultati con QR code / Professional battery tester with integrated printer for 12/24V batteries and charging/starting systems. Tester for quick and accurate testing of the battery, alternator, starter and ground. Analizza la maggior parte dei modelli di batteria (CCA, BCI, CA, MCA, JIS, DIN, IEC, EN, SAE, GB) fornendo risultati con QR code

| Sku | Tensione nominale / Rated voltage | Note / Notes |
|-------|-----------------------------------|--|
| 94045 | 12/24V | DISPLAY MULTILINGUE. Tipi di batterie Trad., gel, MF, AGM, VRLA. Range operativo (CCA batterie) 40-2000 CCA (SAE), 40-2100 CCA (EN), 30-1500 CCA (IEC), 25-1300 CCA (DIN). |

MULTIMETRO UNIVERSALE

MULTIFUNCTION MULTIMETER
 MULTIMÈTRE MULTIFONCTION
 MULTIFUNKTIONSMULTIMETER
 MULTÍMETRO MULTIFUNCIONAL



| Skü | Tensione nominale / Rated voltage | Descrizione / Description |
|-------|-----------------------------------|--|
| 84699 | 600 V | Multimetro digitale portatile; interruttore di accensione a slitta; display di misura 3 digit e 1/2 (1999 max); contenitore antiurto in gomma. Misure di tensione continua e alternata; misura di resistenza elettrica; prova diodi; misura di corrente elett / Portable digital multimeter; slide switch; 3 1/2 digit measuring display (1999 max); shock-proof rubber case. DC and AC voltage measurement; electrical resistance measurement; diode test; electric current measurement |

INTERRUTTORE STACCABATTERIA 12-24V 100A

BATTERY SWITCH 12-24V 100A
 INTERRUPTEUR DE BATTERIE 12-24V 100A
 BATTERIESCHALTER 12-24V 100A
 INTERRUPTOR DE BATERIA 12-24V 100A

Articoli a ricambio

65010M Chiave a ricambio per articolo 65010

| Skü | Tensione nominale / Rated voltage | Intensità di corrente / Current intensity | Spunto / Cue | Chiave / Spanner | Contatti elettrici / Electrical contacts | Diametro di foratura / Drilling diameter | Interasse fori / Hole spacing | Grado protezione ip / Degree of protection ip | Temperatura di esercizio / Operating temperature |
|-------|-----------------------------------|---|---|------------------------|--|--|-------------------------------|---|--|
| 65010 | 12-24 V | 100 A | 500 A per 10 secondi / 500 A - 10 seconds | Removibile / Removable | Viti M10/ M10 screws | 23 mm | 40 mm | IP66 | -40°C / +85°C |

INTERUTTORE STACCABATTERIA MAX 24V 100A

BATTERY SWITCH MAX 24V 100A
 INTERRUPTEUR DE BATTERIE MAX 24V 100A
 BATTERIESCHALTER MAX 24V 100A
 INTERRUPTOR DE BATERÍA MAX 24V 100A



1



2

Articoli a ricambio

62116 Chiave rossa

| Skù | Pos. | Tensione nominale / Rated voltage | Intensità di corrente / Current intensity | Spunto / Cue | Chiave / Spanner | Contatti elettrici / Electrical contacts | Diametro di foratura / Drilling diameter | Interasse fori / Hole spacing | Grado protezione ip / Degree of protection ip | Temperatura di esercizio / Operating temperature | Confezionamento / Packaging |
|--------|------|-----------------------------------|---|---|------------------------|--|--|---|---|--|---------------------------------|
| 09862 | 1 | Max 24 V | 100 A | 500 A per 5 secondi / 500 A for 5 seconds | Removibile / Removable | viti M8 / M8 screws | 24 mm | 38 mm, diametro foro viti 6,5 mm / 38 mm, screw hole Ø 6.5 mm | IP4X | -40° C / +50° C | |
| 09862C | 2 | Max 24 V | 100 A | 500 A per 5 secondi / 500 A for 5 seconds | Removibile / removable | viti M8 / M8 screws | 24 mm | 38 mm, diametro foro viti 6,5 mm / 38 mm, screw hole Ø 6.5 mm | IP4X | -40° C / +50° C | busta appendibile / Hanging bag |

INTERUTTORE STACCABATTERIA MAX 24V 100A

BATTERY SWITCH MAX 24V 100A
 INTERRUPTEUR DE DÉCONNEXION DE BATTERIE MAX 24V 100A
 BATTERIE-TRENNSCHALTER MAX 24V 100A
 INTERRUPTOR DE DESCONEXIÓN DE BATERÍA MAX 24V 100A

**Articoli a ricambio**

62116 Chiave rossa

| Skù | Tensione nominale / Rated voltage | Intensità di corrente / Current intensity | Spunto / Cue | Chiave / Spanner | Contatti elettrici / Electrical contacts | Diametro di foratura / Drilling diameter | Interasse fori / Hole spacing | Grado protezione ip / Degree of protection ip | Temperatura di esercizio / Operating temperature |
|--------|-----------------------------------|---|---|------------------------|--|--|---|---|--|
| M21047 | Max 24 V | 100 A | 500 A per 5 secondi / 500 A for 5 seconds | Removibile / removable | Viti M8/ M8 screws | 24 mm | 38 mm, fori Ø 6,5 mm / 38 mm, screw hole Ø 6.5 mm | IP4X | -40°C / +85°C |

INTERRUTTORE STACCABATTERIA MAX 24V 150A

BATTERY SWITCH MAX 24V 150A
 INTERRUPTEUR DE BATTERIE MAX 24V 150A
 BATTERIESCHALTER MAX 24V 150A
 INTERRUPTOR DE BATERÍA MAX 24V 150A



| Skü | Tensione nominale / Rated voltage | Intensità di corrente / Current intensity | Spunto / Cue | Chiave / Spanner | Contatti elettrici / Electrical contacts | Diametro di foratura / Drilling diameter | Interasse fori / Hole spacing | Grado protezione ip / Degree of protection ip | Temperatura di esercizio / Operating temperature |
|---------------|-----------------------------------|---|---|------------------------|--|--|--|---|--|
| M21269 | Max 24 V | 150 A | 1000 A per 5 secondi / 1000 A for 5 seconds | Removibile / Removable | Viti M10/ M10 screws | 16 mm, trou de vis Ø 7 mm / 16 mm, screw hole Ø 7 mm | 16 mm, foro viti Ø 7 mm / 16 mm, screw hole Ø 7 mm | IP63 | -40°C / +85°C |

INTERRUTTORE STACCABATTERIA MAX 24V 150A

BATTERY SWITCH MAX 24V 150A
 INTERRUPTEUR DE BATTERIE MAX 24V 150A
 BATTERIESCHALTER MAX 24V 150A
 INTERRUPTOR DE BATERÍA MAX 24V 150A



| Skü | Tensione nominale / Rated voltage | Intensità di corrente / Current intensity | Spunto / Cue | Chiave / Spanner | Contatti elettrici / Electrical contacts | Diametro di foratura / Drilling diameter | Interasse fori / Hole spacing | Grado protezione ip / Degree of protection ip | Temperatura di esercizio / Operating temperature |
|--------------|-----------------------------------|---|---|------------------------|--|--|-------------------------------|---|--|
| 65011 | 12-24 V | 150 A | 1000 A per 5 secondi / 1000 A for 5 seconds | Removibile / Removable | Viti M10/ M10 screws | 5x7 mm | 43 mm | IP55 | -40°C / +85°C |

INTERRUTTORE STACCABATTERIA 12-24V 200A

BATTERY SWITCH 12-24V 200A
 INTERRUPTEUR DE BATTERIE 12-24V 200A
 BATTERIESCHALTER 12-24V 200A
 INTERRUPTOR DE BATERÍA 12-24V 200A

Articoli a ricambio

65027M Chiave a ricambio per articolo 65027

| Skü | Tensione nominale / Rated voltage | Intensità di corrente / Current intensity | Spunto / Cue | Chiave / Spanner | Contatti elettrici / Electrical contacts | Diametro di foratura / Drilling diameter | Interasse fori / Hole spacing | Grado protezione ip / Degree of protection ip | Temperatura di esercizio / Operating temperature |
|--------------|-----------------------------------|---|----------------------|------------------------|--|--|--|---|--|
| 65027 | 12-24 V | 200 A | / 1000 A - 5 seconds | Removibile / Removable | Viti M10/ M10 screws | 23 mm | 38 mm, foro Ø 6,5 mm / 38 mm, screw holes Ø 6,5 mm | IP67 | -40°C / +85°C |

INTERRUTTORE STACCABATTERIA MAX 24V 250A

BATTERY SWITCH MAX 24V 250A
 INTERRUPTEUR DE BATTERIE MAX 24V 250A
 BATTERIESCHALTER MAX 24V 250A
 INTERRUPTOR DE BATERÍA MAX 24V 250A



| Skü | Tensione nominale / Rated voltage | Intensità di corrente / Current intensity | Spunto / Cue | Chiave / Spanner | Contatti elettrici / Electrical contacts | Diametro di foratura / Drilling diameter | Interasse fori / Hole spacing | Grado protezione ip / Degree of protection ip | Temperatura di esercizio / Operating temperature |
|--------------|-----------------------------------|---|---|--------------------------------|--|--|---|---|--|
| 09181 | Max 24 V | 250 A | 2500 A per 5 secondi / 2500 A for 5 seconds | non removibile / Non-removable | viti M10/ M10 screws | 30 mm | 60 mm, diametro foro 4,5 mm / 60 mm, hole diameter Ø 4.5 mm | IP65 | -40° C / +80° C |

INTERRUTTORE STACCABATTERIA A MOLLA 12-24V 250A

BATTERY SWITCH MAX 24V 200A
 INTERRUPTEUR DE BATTERIE MAX 24V 200A
 BATTERIESCHALTER MAX 24V 200A
 INTERRUPTOR DE BATERÍA MAX 24V 200A



| Skü | Tensione nominale / Rated voltage | Specifiche / Specifications | Intensità di corrente / Current intensity | Spunto / Cue | Chiave / Spanner | Contatti elettrici / Electrical contacts | Diametro di foratura / Drilling diameter | Interasse fori / Hole spacing | Grado protezione ip / Degree of protection ip | Temperatura di esercizio / Operating temperature |
|--------------|-----------------------------------|-----------------------------|---|---|--------------------------------|--|---|-------------------------------|---|--|
| 55301 | 12-24 V | a molla / spring-loaded | 250 A | 2500 A per 3 secondi, 1500 A per 30 secondi / 2500 A for 3 seconds, 1500 A for 30 seconds | non removibile / non-removable | viti M10 / M10 screws | 30 mm, diametro viti 7 mm / 30 mm, screw Ø 7 mm | 45 mm | IP67/IP69K | -40° C / +85° C |

INTERRUTTORE STACCABATTERIA 12-24V 250A

BATTERY SWITCH 12-24V 250A
 INTERRUPTEUR DE BATTERIE 12-24V 250A
 BATTERIESCHALTER 12-24V 250A
 INTERRUPTOR DE BATERÍA 12-24V 250A



| Skü | Tensione nominale / Rated voltage | Intensità di corrente / Current intensity | Spunto / Cue | Chiave / Spanner | Contatti elettrici / Electrical contacts | Diametro di foratura / Drilling diameter | Interasse fori / Hole spacing | Grado protezione ip / Degree of protection ip | Temperatura di esercizio / Operating temperature |
|--------------|-----------------------------------|---|---|------------------------------|--|--|-------------------------------|---|--|
| 65012 | 12-24 V | 250 A | 1000 A per 5 secondi / 1000 A - 5 seconds | Non removibile / Unremovable | Viti M10/ M10 screws | 29 mm | 45 mm | IP55 | -40° C / +85° C |

INTERRUTTORE STACCABATTERIA 12-24V 250A

BATTERY SWITCH 12-24V 250A
 INTERRUPTEUR DE BATTERIE 12-24V 250A
 BATTERIESCHALTER 12-24V 250A
 INTERRUPTOR DE BATERÍA 12-24V 250A

Articoli a ricambio

65018M

Maniglia a ricambio per interruttore staccabatteria 65018

| Skù | Tensione nominale / Rated voltage | Intensità di corrente / Current intensity | Spunto / Cue | Chiave / Spanner | Contatti elettrici / Electrical contacts | Diametro di foratura / Drilling diameter | Interasse fori / Hole spacing | Grado protezione ip / Degree of protection ip | Temperatura di esercizio / Operating temperature |
|-------|-----------------------------------|---|--|------------------------|--|--|-------------------------------|---|--|
| 65018 | 12-24 V | 250 A | 2500 A per 5 secondi / 2500A for 5 seconds | Removibile / Removable | Viti M10/ M10 screws | 22,5 mm | 99,5 mm | IP67 | -40°C / +85°C |

INTERRUTTORE STACCABATTERIA MAX 48V 300A

BATTERY SWITCH MAX 48V 300A
 INTERRUPTEUR DE BATTERIE MAX 48V 300A
 BATTERIESCHALTER MAX 48V 300A
 INTERRUPTOR DE BATERÍA MAX 48V 300A



| Skù | Tensione nominale / Rated voltage | Intensità di corrente / Current intensity | Spunto / Cue | Chiave / Spanner | Contatti elettrici / Electrical contacts | Diametro di foratura / Drilling diameter | Interasse fori / Hole spacing | Grado protezione ip / Degree of protection ip | Temperatura di esercizio / Operating temperature |
|-------|-----------------------------------|---|---|--------------------------------|--|--|-------------------------------|---|--|
| 65022 | Max 48 V | 300 A | 2500 A per 5 secondi / 2500 A for 5 seconds | Non removibile / Non-removable | Vite M12, vite M10/ M12 screw, M10 screw | 30,5 mm | 30 mm | IP67 | -40°C / +85°C |

INTERRUTTORE STACCABATTERIA MAX 48V 300A



BATTERY SWITCH MAX 48V 300A
 INTERRUPTEUR DE BATTERIE MAX 48V 300A
 BATTERIESCHALTER MAX 48V 300A
 INTERRUPTOR DE BATERÍA MAX 48V 300A



| Skù | Tensione nominale / Rated voltage | Intensità di corrente / Current intensity | Spunto / Cue | Chiave / Spanner | Contatti elettrici / Electrical contacts | Diametro di foratura / Drilling diameter | Interasse fori / Hole spacing | Grado protezione ip / Degree of protection ip | Temperatura di esercizio / Operating temperature |
|-------|-----------------------------------|---|---|------------------------------|--|--|-------------------------------|---|--|
| 65025 | Max 48 V | 300 A | 2500 A per 5 secondi / 2500 A for 5 seconds | Non removibile / unremovable | Viti M10/ M10 screws | 30,5 mm | 30 mm | IP67 | -40°C / +85°C |

INTERRUTTORE STACCABATTERIA 12-24V 300A CON MANIGLIA ROTATIVA

BATTERY SWITCH 12-24V 300A WITH ROTARY HANDLE
 INTERRUPTEUR DE BATTERIE 12-24V 300A AVEC POIGNÉE ROTATIVE
 BATTERIESCHALTER 12-24V 300A MIT DREHGRIF
 INTERRUPTOR DE BATERÍA 12-24V 300A CON MANIJA ROTATIVA

| Skü | Tensione nominale / Rated voltage | Intensità di corrente / Current intensity | Spunto / Cue | Chiave / Spanner | Contatti elettrici / Electrical contacts | Interasse fori / Hole spacing | Grado protezione ip / Degree of protection ip | Temperatura di esercizio / Operating temperature |
|---|-----------------------------------|---|---|---------------------------------|--|--|---|--|
|  65930 | 12-24 V | 300 A | 1000 A per 5 secondi / 1000 A for 5 seconds | Rotativa ON-OFF / Rotary ON-OFF | Viti M10 / M10 screws | 55x55 mm, fori Ø 6,5 mm / 55x55 mm, holes Ø 6.5 mm | IP66 | -40°C / +85°C |
|  65965 | 12-24 V | 300 A | 1250 A per 5 secondi / 1250 A for 5 seconds | Rotativa ON-OFF / Rotary ON-OFF | Viti M10 / M10 screws | 55x55 mm, fori Ø M5 / 55x55 mm, holes Ø 5.5 mm | IP67 | -40°C / +50°C |

INTERRUTTORE STACCABATTERIA 6-36V 400A

BATTERY SWITCH 6-36V 400A
 INTERRUPTEUR DE DÉCONNEXION DE BATTERIE 6-36V 400A
 BATTERIESCHALTER 6-36V 400A
 INTERRUPTOR DE DESCONEXIÓN DE BATERÍA 6-36V 400A



| Skü | Tensione nominale / Rated voltage | Intensità di corrente / Current intensity | Spunto / Cue | Chiave / Spanner | Contatti elettrici / Electrical contacts | Grado protezione ip / Degree of protection ip | Temperatura di esercizio / Operating temperature |
|-------|-----------------------------------|---|---|--------------------------------|--|---|--|
| 65047 | 6-36 V | 12V: 400 A, 24V: 300 A, 36V: 200 A | 12V: 3000 A per 15 secondi / 12V: 3000 A for 15 seconds | Non removibile / Non-removable | Viti M10 / M10 screws | IP67 | -40°C / +85°C |

INTERRUTTORE STACCABATTERIA MAX 48V 450A

BATTERY SWITCH MAX 24V 450A
 INTERRUPTEUR DE BATTERIE MAX 24V 450A
 BATTERIESCHALTER MAX 24V 450A
 INTERRUPTOR DE BATERÍA MAX 24V 450A



| Skü | Tensione nominale / Rated voltage | Intensità di corrente / Current intensity | Spunto / Cue | Chiave / Spanner | Contatti elettrici / Electrical contacts | Interasse fori / Hole spacing | Grado protezione ip / Degree of protection ip | Temperatura di esercizio / Operating temperature |
|-------|-----------------------------------|---|---|--------------------------------|--|-------------------------------|---|--|
| 65021 | Max 48 V | 450 A | 4500A per 5 secondi / 4500A for 5 seconds | Non removibile / Non-removable | Viti M10 / M10 screws | 63 mm | IP67 | -40°C / +85°C |

ELETTROLITO PER BATTERIE

BATTERY ACID
ACIDE SULFURIQUE
BATTERIESÄURE
ÁCIDO DE BATERÍA



| Skü | Note / Notes | Dimensioni / Dimensions |
|--------------|---|-------------------------|
| 09565 | Omologazione: ONU UN4G/Y28/2015/SSCCP/00234-0811/CPABS0140-13/BRIA12MP30 / ONU UN4G/Y28/2015/SSCCP/00234-0811/CPABS0140-13/BRIA12MP30 | 5 lt |
| 37332 | Omologazione: ONU UN4G/Y28/2015/SSCCP/00234-0811/CPABS0140-13/BRIA12MP30 / ONU UN4G/Y28/2015/SSCCP/00234-0811/CPABS0140-13/BRIA12MP30 | 1 lt |

ACQUA DEMINERALIZZATA

DEMINERALIZED WATER
EAU DÉMINÉRALISÉE
DEMINERALISIERTES WASSER
AGUA DESMINERALIZADA



| Skü | Note / Notes | Dimensioni / Dimensions |
|--------------|---|-------------------------|
| 15927 | Acqua Indicata per il rabbocco delle batterie ad acido, per usi industriali, officine meccaniche, accumulatori, ferri da stiro, acquari, circuiti di raffreddamento, processi industriali. Evita le incrostazioni calcaree. / Suitable for topping up lead-acid batteries, for industrial use, mechanical workshops, accumulators, irons, aquariums, cooling circuits, and industrial processes. Prevents limescale build-up. | 5 lt |
| 56992 | Acqua Indicata per il rabbocco delle batterie ad acido, per usi industriali, officine meccaniche, accumulatori, ferri da stiro, acquari, circuiti di raffreddamento, processi industriali. Evita le incrostazioni calcaree. / Suitable for topping up lead-acid batteries, for industrial use, mechanical workshops, accumulators, irons, aquariums, cooling circuits, and industrial processes. Prevents limescale build-up. | 10 lt |

ACCESSORI PER BATTERIA

BATTERY ACCESSORIES
ACCESSOIRES POUR BATTERIE
ZUBEHÖR FÜR BATTERIEN
ACCESORIOS PARA BATERÍA

1

2

| Skü | Pos. | Descrizione / Description |
|--------------|------|--|
| 84696 | 1 | Pulitore a spazzola, per togliere rapidamente le incrostazioni nocive sia dai poli che dai morsetti della batteria / Brush cleaner, to quickly remove harmful deposits from both battery poles and terminals |
| 84698 | 2 | densimetro per antigelo / densimeter for antifreeze |

DISSODIDANTE SECCO PER CONTATTI ELETTRICI

DRY DEOXIDIZER FOR ELECTRONIC CONTACTS
 DÉSOXYDANT SEC POUR CONTACTS ÉLECTRONIQUES
 KONTAKSPRAY
 DEOXIDANTE SECO



| Skü | Colore / Colour | Capacità / Capacity | Descrizione / Description |
|-------|-----------------|---------------------|---|
| 78740 | senza colore | 400 ml | DISSODIDANTE SECCO CONTATTI ELETTRICI 400ML Prodotto testato per la disossidazione di componenti e materiale elettrici ed elettronici. Di rapida essiccazione, evapora in pochi secondi senza lasciare residui. Settori: officine meccaniche, ferramenta automobilistico, applicazioni di vario tipo ad uso / Flux Specifically developed for the deoxidization of components on all electric and electronic equipment. Strong penetrating properties, quick evaporation; the products does not leave remainders. Properties: deoxidizer, antioxidant, quick evaporation. |

DISSODIDANTE OLEOSO PER CONTATTI ELETTRICI

OIL BASED DEOXIDIZER FOR ELECTRONIC CONTACTS
 DÉSOXYDANT À BASE D'HUILE POUR CONTACTS ÉLECTRIQUE
 KONTAKSPRAY MIT KORROSIONSSCHUTZ
 DESOXIDANTE OLEOSO PARA CONTACTOS ELÉCTRICOS



| Skü | Capacità / Capacity | Descrizione / Description |
|-------|---------------------|--|
| 78741 | 400 ml | DISSODIDANTE OLEOSO CONTATTI ELETTRICI 400ML Spray idoneo per apparecchiature elettroniche, relè contatti, centraline e semiconduttori. Penetra rapidamente e con facilità in zone di difficile accesso. Evapora in pochi secondi senza lasciare residui. E' idrorepellente e previene la corrosione. / Flux Suitable for electric equipment, relays, contact, switchboard, semi-conductors. Penetrate quickly and easily in otherwise hard to reach areas. Quick evaporation no remainders. Properties: deoxidizer, antioxidant, quick evaporation. |

PROTETTIVO PER POLI BATTERIE

BATTERY TERMINALS PROTECTIVE AGENT
 PORTECTEUR POUR COSSES DE BATTERIE
 SCHUTZ FÜR BATTERIEPOLE
 AGENTE PROTECTOR PARA BORNES DE BATERIA



| Skü | Colore / Colour | Capacità / Capacity | Descrizione / Description |
|-------|-----------------|---------------------|---|
| 78742 | pastoso rosa | 400 ml | Protettivo poli batteria 400ML Protettivo antiacido per morsetti batteria, è ideale per impedire la solfatazione e la corrosione in rame o bronzo. E' resistente alle variazioni di temperatura. Proprietà: Antiadesivo, antiossidante, anticorrosivo. / protective poly an anti-acid protctive agent for battery terminals, it is the ideal product to prevent sulfation and corrosion of copper or bronze terminals. Resitant of great temperature variations. Properties: antiadhesive, antioxidant, and anti corrosion characteristics. |



Girofari e piantoni

Beacons and beacon holders

I prodotti recanti il marchio AMA qui indicati sono realizzati da AMA S.p.A. e destinati a essere utilizzati come ricambi adattabili e non originali. I riferimenti a marchi, codici originali e costruttori di terzi, riportati in corrispondenza degli articoli AMA compatibili, hanno esclusivamente la finalità di identificare il modello, l'applicazione o la destinazione d'uso del prodotto, in conformità a quanto previsto dal Regolamento (CE) n. 1400/2002 e dalla normativa vigente in materia di concorrenza e uso lecito dei marchi di terzi. / The products bearing the AMA brand name listed here are manufactured by AMA S.p.A. and are intended for use as adaptable, non-original spare parts. References to trademarks, original codes and third-party manufacturers, shown alongside compatible AMA items, are intended solely to identify the model, application or intended use of the product, in accordance with Regulation (EC) No. 1400/2002 and current legislation on competition and the lawful use of third-party trademarks.

GIROFARI LED A BATTERIA 12-24V, 6 ORE DI AUTONOMIA

BEACON LED RECHARGEABLE 12-24V, 6 HOURS OF RUNTIME

GYROPHARE LED RECHARGEABLE 12-24V, AUTONOMIE DE 6 HEURES

LED-RUNDUMLEUCHTE WIEDERAUFLADBAR 12-24V, 6 STUNDEN LAUFZEIT

FARO DESTELLANTE LED RECARGABLE 12-24V, 6 HORAS DE AUTONOMIA



1



2

Articoli a ricambio

| | | |
|---|--------------|--|
|  | 66008 | Spina per alimentazione batteria |
|  | 66009 | Spina accendisigari per alimentazione batteria |
|  | 66149 | Telecomando per girofari art. 66150 e art. 68081 |

ECE, CE, RoHS, RED e UKCA

| Skù | Pos. | Tipo luce / Light type | Linea / Line | Tensione nominale / Rated voltage | Funzioni / Functions | Numero led / Number of LEDs | Descrizione / Description | Grado protezione ip / Degree of protection ip | Temperatura di esercizio / Operating temperature | Corpo faro / Light body | Materiale lente / Lens material |
|--------------|------|---------------------------|---|---|--|-----------------------------------|--|--|---|----------------------------|---------------------------------------|
| 66010 | 1 | LED | Base magnetica / Magnetic base | 12-24 V | 3 modalità flash e 4 modalità di rotazio- ne / 3 modes flash & 4 modes rotation | 10 | Durata batteria 6 ore, tempo di ricarica 4 ore / Discharging time 6 hours, charging time 4 hours | IP67 | -40° / +65° C | ABS | PC |
| 66150 | 2 | LED | Base magnetica / Magnetic base | 12-24 V | 3 modalità flash e 4 modalità di rotazio- ne / 3 modes flash & 4 modes rotation | 10 | Durata batteria 6 ore, tempo di ricarica 4 ore / Discharging time 6 hours, charging time 4 hours | IP67 | -40° / +65° C | ABS | PC |

GIROFARO MAGNETICO A LED A BATTERIA 12-24V

RECHARGEABLE MAGNETIC LED BEACON 12-24V
 GYROPHARE À LED MAGNÉTIQUE ALIMENTÉE PAR BATTERIE 12-24V
 WIEDERAUFLADBARE MAGNETISCHE LED-RUNDUMLEUCHTE 12-24V
 BALIZA LED RECARGABLE MAGNÉTICA 12-24V

1

2
Articoli a ricambio

| | | |
|--|--------------|--|
|  | 66008 | Spina per alimentazione batteria |
|  | 66009 | Spina accendisigari per alimentazione batteria |
|  | 66149 | Telecomando per girofari art. 66150 e art. 68081 |

ECE, CE, RoHS, RED e UKCA

| Skù | Pos. | Tipo luce / Light type | Linea / Line | Tensione nominale / Rated voltage | Funzioni / Functions | Descrizione / Description | Grado protezione ip / Degree of protection ip | Temperatura di esercizio / Operating temperature | Corpo faro / Light body | Materiale lente / Lens material |
|--------------|------|------------------------|--------------------------------|-----------------------------------|---|--|---|--|-------------------------|---------------------------------|
| 68080 | 1 | LED | Base magnetica / Magnetic base | 12-24 V | 3 modalità flash e 4 modalità di rotazione / 3 modes flash & 4 modes rotation | Durata batteria 6,5 ore, tempo di ricarica 4 ore / Discharging time 6,5 hours, charging time 4 hours | IP67 | -40° / +65° C | Alluminio | PC |
| 68081 | 2 | LED | Base magnetica / Magnetic base | 12-24 V | 3 modalità flash e 4 modalità di rotazione / 3 modes flash & 4 modes rotation | Durata batteria 6,5 ore, tempo di ricarica 4 ore / Discharging time 6,5 hours, charging time 4 hours | IP67 | -40° / +65° C | Alluminio | PC |

SET DA 2 LAMPEGGIANTI LED SINCRONIZZATI 12-24V

SET OF 2 SYNCHRONIZED LED BEACONS, 12-24V
 SET DE 2 GYROPHARES LED SYNCHRONISÉS, 12-24V
 SET AUS 2 SYNCHRONISIERTEN LED-BLITZLEUCHTEN, 12-24V
 SET DE 2 BALIZAS LED SINCRONIZADAS, 12-24V



| Skù | Tipo luce / Light type | Modello / Model | Linea / Line | Tensione nominale / Rated voltage | Funzioni / Functions | Numero led / Number of LEDs | Grado protezione ip / Degree of protection ip | Temperatura di esercizio / Operating temperature | Corpo faro / Light body | Materiale lente / Lens material |
|--------------|------------------------|------------------------------|-----------------------|-----------------------------------|---|-----------------------------|---|--|-------------------------|---------------------------------|
| 65137 | LED | sincronizzati / synchronized | Base flex / DIN mount | 12-24 V | Flash singolo sincronizzato, Flash singolo alternato, Flash doppio sincronizzato, Flash doppio alternato, Rotazione sincronizzata / Synchronized single flash, alternating single flash, synchronized double flash, alternating double flash, synchronized rotation | 4 | IP66 | -20°C / +50°C | ABS | PC |

GIROFARI LED 12-24V, 27W, 18 LED

BEACON LED 12-24V, 27W, 18 LED
 GYROPHARE LED 12-24V, 27W, 18 LED
 LED-RUNDUMLEUCHTE 12-24V, 27W, 18 LED
 FARO DESTELLANTE LED 12-24V, 27W, 18 LED



1



2



3

Articoli a ricambio



04597

Cavo spiralato con spina ON/OFF e pulsante per selezionare il flash

ECE, CE, RoHS, UKCA, CISPR 25 CLASSE 3

| Skü | Pos. | Tipo luce / Light type | Linea / Line | Tensione nominale / Rated voltage | Funzioni / Functions | Numero led / Number of LEDs | Grado protezione ip / Degree of protection ip | Corpo faro / Light body | Temperatura di esercizio / Operating temperature | Materiale lente / Lens material |
|-------|------|------------------------|--------------------------------|-----------------------------------|--|-----------------------------|---|-------------------------|--|---------------------------------|
| 63120 | 1 | LED | Base piana / Flat base | 12-24 V | Flash singolo, Doppio flash veloce, Doppio flash lento, Triplo flash, Quad flash, Mega flash, Rotazione / 7 Flash patterns: Single flash, Double flash, Double flash - slow, Triple flash, Quad flash, Mega flash, Rotate. Multiple units are synchronizable and can flash simultaneously. | 18 | IP67 | Alluminio / Aluminium | -30° / +60° C | PC |
| 63121 | 2 | LED | Base magnetica / Magnetic base | 12-24 V | Flash singolo, Doppio flash veloce, Doppio flash lento, Triplo flash, Quad flash, Mega flash, Rotazione / 7 Flash patterns: Single flash, Double flash, Double flash - slow, Triple flash, Quad flash, Mega flash, Rotate. | 18 | IP67 | Alluminio / Aluminium | -30° / +60° C | PC |
| 63122 | 3 | LED | Base flex / DIN pole mount | 12-24 V | Flash singolo, Doppio flash veloce, Doppio flash lento, Triplo flash, Quad flash, Mega flash, Rotazione / 7 Flash patterns: Single flash, Double flash, Double flash - slow, Triple flash, Quad flash, Mega flash, Rotate. | 18 | IP67 | Flex | -30° / +60° C | PC |

GIROFARO A LED BASE PIANA, 10-110V

LED BEACON, SCREW MOUNTING BASE, 10-110V
 GYROPHARE LED À BASE PLATE, 10-110V
 LED-RUNDUMLEUCHTE MIT FLACHEM SOCKEL, 10-110V
 BALIZA LED CON BASE PLANA, 10-110V



| Skü | Tensione nominale / Rated voltage | Funzioni / Functions | Numero led / Number of LEDs | Grado protezione ip / Degree of protection ip | Temperatura di esercizio / Operating temperature | Omologazioni / Homologations |
|-------|-----------------------------------|--|-----------------------------|---|--|------------------------------|
| 65103 | 10-110 V | Flash singolo, Flash doppio / Single flash, Double flash | 8 | IP65 | -30°C / +50°C | ECE-R10, ECE-R65 |

GIROFARI LED 12-24V, 16W, 12 LED

 BEACON LED 12-24V, 16W, 12 LED
 GYROPHARE LED 12-24V, 16W, 12 LED
 LED-RUNDUMLEUCHTE 12-24V, 16W, 12 LED
 FARO DESTELLANTE LED 12-24V, 16W, 12 LED

1

2

3
Articoli a ricambio

59113 Calotta a ricambio

04593 Cavo spiralato con spina agricola on/off

04594 Spina agricola on/off

ECE, CE, RoHS, UKCA, CISPR 25 CLASSE 3

| Skü | Pos. | Tipo luce / Light type | Linea / Line | Tensione nominale / Rated voltage | Funzioni / Functions | Numero led / Number of LEDs | Grado protezione ip / Degree of protection ip | Temperatura di esercizio / Operating temperature | Corpo faro / Light body | Materiale lente / Lens material |
|--------------|------|------------------------|--------------------------------|-----------------------------------|---|-----------------------------|---|--|-------------------------|---------------------------------|
| 60116 | 1 | LED | Base piana / Bolt-on base | 12-24 V | Rotazione, Flash singolo, Doppio flash, Quad flash / Pattern: rotation, single flash, quick flash | 12 | IP66 | -30° / +60° C | PP | PC |
| 60117 | 2 | LED | Base flex / Flexi base | 12-24 V | Rotazione, Flash singolo, Doppio flash, Quad flash / Pattern: rotation, single flash, quick flash | 12 | IP66 | -30° / +60° C | PP | PC |
| 60118 | 3 | LED | Base magnetica / Magnetic base | 12-24 V | Rotazione, Flash singolo, Doppio flash, Quad flash / Pattern: rotation, single flash, quick flash | 12 | IP66 | -30° / +60° C | PP | PC |

LAMPEGGIANTE 12-24V LED VERDI E ARANCONI PER SEGNALAZIONE VEICOLI AL LAVORO

 WARNING LED BEACON 12-24 V, 20 W FOR WORK VEHICLES
 GYROPHARE LED 12-24 V VERT ET ORANGE POUR VÉHICULES DE CHANTIER
 LED-RUNDUMKENNLEUCHTE 12-24 V IN GRÜN UND ORANGE FÜR BAUSTELLENFAHRZEUGE
 BALIZA LED 12-24 V VERDE Y AMBAR PARA VEHÍCULOS DE TRABAJO

Operatore seduto e cintura allacciata
 Operator seated with seatbelt fastened

Veicolo operativo in area di lavoro
 Vehicle operating in work zone – slow speed

| Skü | Tipo luce / Light type | Linea / Line | Tensione nominale / Rated voltage | Funzioni / Functions | Numero led / Number of LEDs | Temperatura di esercizio / Operating temperature | Grado protezione ip / Degree of protection ip |
|--------------|------------------------|---------------------------------|-----------------------------------|--|---|--|---|
| 65002 | LED | Base flex / Flexible pole mount | 12-24 V | Operatore seduto e cintura allacciata lampeggio verde: Flash singolo, Doppio flash, Quad flash, Fisso. Veicolo operativo in area di lavoro lampeggio arancione: Flash singolo (ECE-R65), Doppio flash (ECE-R65), Quad flash (ECE-R65), Rotazione. / Operator seated with seatbelt fastened green flash: Single flash, Double flash, Quad flash, Steady on. Vehicle operating in work zone amber flash: Single flash (ECE R65), Double flash (ECE R65), Quad flash (ECE R65), Rotation. | 24 LED arancioni, 24 LED verdi / 24 amber, 24 green | -30°C / +60°C | IP67 |

GIROFARI LED 12-24V, 12W, 8 LED

BEACON LED 12-24V, 12W, 8 LED
 GYROPHARE LED 12-24V, 12W, 8 LED
 LED-RUNDUMLEUCHTE 12-24V, 12W, 8 LED
 FARO DESTELLANTE LED 12-24V, 12W, 8 LED



1



2



3

Articoli a ricambio

| | | |
|--|--------------|---|
| | 55404 | Calotta girofaro art. 55401, 55402, 55403 |
| | 04593 | Cavo spiralato con spina agricola on/off |
| | 04594 | Spina agricola on/off |

ECE, CE, RoHS, UKCA, CISPR 25 CLASSE 3

| Skù | Pos. | Tipo luce / Light type | Linea / Line | Tensione nominale / Rated voltage | Funzioni / Functions | Numero led / Number of LEDs | Temperatura di esercizio / Opera- ting temperature | Grado protezio- ne ip / Degree of protection ip | Corpo faro / Light body | Materiale lente / Lens material |
|-------|------|---------------------------|--|---|--|-----------------------------------|--|---|----------------------------|---------------------------------------|
| 55401 | 1 | LED | Base piana / Bolt-on base | 12-24 V | Rotazione, Flash singolo, Doppio flash, Quad flash / Four types of flash: Rotation, Single flash Double flash, Triple (Octa) flash. | 12 | -30° / +60° C | IP66 | PC | PP |
| 55402 | 2 | LED | Base magneti- ca / Magnetic base | 12-24 V | Rotazione, Flash singolo, Doppio flash, Quad flash / Four types of flash: Rotation, Single flash Double flash, Triple (Octa) flash. | 12 | -30° / +60° C | IP66 | PC | PP |
| 55403 | 3 | LED | Base flex / Flexi base | 12-24 V | Rotazione, Flash singolo, Doppio flash, Quad flash / Four types of flash: Rotation, Single flash Double flash, Triple (Octa) flash. | 12 | -30° / +60° C | IP66 | PC | PP |

GIROFARI LED 12-24V, 16W, 24 LED

BEACON LED 12-24V, 16W, 24 LED
 GYROPHARE LED 12-24V, 16W, 24 LED
 LED-RUNDUMLEUCHTE 12-24V, 16W, 24 LED
 FARO DESTELLANTE LED 12-24V, 16W, 24 LED

1

2

3
Articoli a ricambio

59114 Calotta a ricambio

04593 Cavo spiralato con spina agricola on/off

04594 Spina agricola on/off

ECE, CE, RoHS, UKCA, CISPR 25 CLASSE 3

| Skù | Pos. | Tipo luce / Light type | Linea / Line | Tensione no- minale / Rated voltage | Funzioni / Functions | Numero led / Number of LEDs | Grado protezione ip / Degree of protection ip | Temperatura di esercizio / Operating temperature | Corpo faro / Light body | Materiale lente / Lens material |
|--------------|------|---------------------------|--|---|---|--------------------------------|---|--|----------------------------|---------------------------------------|
| 62480 | 1 | LED | Base plana / Bolt-on base | 12-24 V | Rotazione, Flash singolo, Doppio flash, Quad flash / Pattern: rotation, sigle flash, quick flash | 24 | IP66 | -30° / +60° C | PP | PC |
| 62481 | 2 | LED | Base flex / Flexi base | 12-24 V | Rotazione, Flash singolo, Doppio flash, Quad flash / Pattern: rotation, sigle flash, quick flash | 24 | IP66 | -30° / +60° C | PP | PC |
| 62482 | 3 | LED | Base magneti- ca / Magnetic base | 12-24 V | Rotazione, Flash singolo, Doppio flash, Quad flash / Pattern: rotation, sigle flash, quick flash | 24 | IP66 | -30° / +60° C | PP | PC |

GIROFARI LED 12-24V, 20W, 30 LED

BEACON LED 12-24V, 20W, 30 LED
 GYROPHARE LED 12-24V, 20W, 30 LED
 LED-RUNDUMLEUCHTE 12-24V, 22W,
 FARO DESTELLANTE LED 12-24V, 20W, 30 LED



1



2



3

Articoli a ricambio

| | | |
|--|--------------|---|
| | 63123 | Calotta girofaro art. 63117, 63118, 63119 |
| | 04593 | Cavo spiralato con spina agricola on/off |
| | 04594 | Spina agricola on/off |

ECE, CE, RoHS, UKCA, CISPR 25 CLASSE 3

| SKU | Pos. | Tipo luce / Light type | Linea / Line | Tensione nominale / Rated voltage | Funzioni / Functions | Numero led / Number of LEDs | Grado protezione ip / Degree of protection ip | Temperatura di esercizio / Operating temperature | Corpo faro / Light body | Materiale lente / Lens material |
|-------|------|------------------------|--------------------------------|-----------------------------------|--|-----------------------------|---|--|-------------------------|---------------------------------|
| 63117 | 1 | LED | Base piana / Bolt-on base | 12-24 V | Flash singolo, Doppio flash, Quad flash, Mega flash / 4 Flash patterns: Single flash, Double flash, Quad flash, Mega flash | 30 | IP67 | -30° / +60° C | PC | PC |
| 63118 | 2 | LED | Base magnetica / Magnetic base | 12-24 V | Flash singolo, Doppio flash, Quad flash, Mega flash / 4 Flash patterns: Single flash, Double flash, Quad flash, Mega flash | 30 | IP67 | -30° / +60° C | PC | PC |
| 63119 | 3 | LED | Base flex / Flexi base | 12-24 V | Flash singolo, Doppio flash, Quad flash, Mega flash / 4 Flash patterns: Single flash, Double flash, Quad flash, Mega flash | 30 | IP67 | -30° / +60° C | PC | PC |

LAMPEGGIANTE MINI A LED 12-24V, 12W, 8 LED

MINI LED BEACON 12-24V, 12W, 8 LED
 GYROPHARE MINI LED 12-24V, 12W, 8 LED
 MINI-LED-RUNDUMLEUCHTE MIT FLEXIBLER BASIS 12-24V, 12W, 8 LED
 BALIZA MINI LED 12-24V, 12W, 8 LED

**Articoli a ricambio**

| | | |
|--|--------------|---|
| | 04597 | Cavo spiralato con spina ON/OFF e pulsante per selezionare il flash |
|--|--------------|---|

ECE, CE, RoHS, UKCA

| SKU | Tipo luce / Light type | Linea / Line | Tensione nominale / Rated voltage | Funzioni / Functions | Numero led / Number of LEDs | Grado protezione ip / Degree of protection ip | Temperatura di esercizio / Operating temperature | Corpo faro / Light body | Materiale lente / Lens material |
|-------|------------------------|--|-----------------------------------|--|-----------------------------|---|--|-------------------------|---------------------------------|
| 68110 | LED | Base magnetica e a ventosa / Magnetic and suction base | 12-24 V | Rotazione (R65), Flash singolo, Flash doppio, Quad flash, Flash Octa, Luce Fissa / Rotation (R65), Single Flash, Double Flash, Quad Flash, Octa Flash, Steady on | 8 | IP67 | -30° / +60° C | Alluminio / Aluminium | PC |

GIROFARI MINI A LED

SMALL LED BEACON LIGHTS
 PETITS GYROPHARES LED
 KLEINE LED-RUNDUMLEUCHTEN
 LUCES GIRATORIAS LED PEQUEÑAS

1

2
Articoli a ricambio

65101L Calotta girofaro 65101

| Skù | Pos. | Tipo luce / Light type | Linea / Line | Tensione nominale / Rated voltage | Funzioni / Functions | Numero led / Number of LEDs | Grado protezione ip / Degree of protection ip | Temperatura di esercizio / Operating temperature |
|--------------|------|---------------------------|----------------------------------|---|---|--------------------------------|---|--|
| 65101 | 1 | LED | Base flex / Flexi base | 12-24 V | Flash singolo, Flash doppio/ Single flash, Double flash | 24 | IP65 | -30° / +50° C |
| 65120 | 2 | LED | Base flex / DIN pole mount | 12-24V | Flash quadruplo, Flash singolo, Flash doppio, Flash ottuplo, Flash singolo lento, Flash singolo - effetto "respiro" lento, Rotazione/ Quadruple flash, single flash, double flash, eight-fold flash, slow single flash, slow single flash "breathing" effect, rotating | 18 | IP67 | -30° / +60° C |

LAMPEGGIANTE A LED 12-24V, 24 LED, 36W. APPROVATO ICAO

LED BEACON 12-24V, 24 LEDS, 36W. ICAO APPROVED
 GYROPHARE LED 12-24V, 24 LEDS, 36W. APPROUVÉ PAR L'ICAO
 RUNDUMLEUCHTE LED MIT FLEXIBLER BASIS 12-24V, 12W, 8 LEDS 12-24V, 24 LEDS, 36W. ICAO-ZERTIFIZIERT
 BALIZA LED 12-24V, 24 LEDS, 36W. APROBADA POR LA ICAO

1

2

3
Articoli a ricambio

68614

 Calotta girofaro ambra in
 policarbonato art. 68611, 68612,
 68613

64495

04597

 Cavo spiralato con spina ON/OFF e
 pulsante per selezionare il flash

ECE, CE, RoHS, UKCA, CISPR 25 CLASSE 4 ICAO, SAE-J845 CLASSE 1

| Skù | Pos. | Tipo luce / Light type | Modello / Model | Tensione nominale / Rated voltage | Funzioni / Functions | Numero led / Number of LEDs | Grado protezio- ne ip / Degree of protection ip | Materiale lente / Lens material | Temperatura di esercizio / Opera- ting temperature |
|--------------|------|---------------------------|---|---|---|-----------------------------------|---|---------------------------------------|--|
| 68611 | 1 | LED | Base piana / Bolt-on base | 12-24 | Flash singolo, Doppio flash, Quad flash, Flash veloce, Rotazio- ne, Rotazione+Quad flash, Flash singolo ICAO / Single flash, Double flash, Quad flash, Quick flash, Rotating flash, Rotating + Quad flash, Single flash ICAO | 24 | IP67 | PC | -30°C a +60°C |
| 68612 | 2 | LED | Base magnetica / Magnetic base | 12-24 | Flash singolo, Doppio flash, Quad flash, Flash veloce, Rotazio- ne, Rotazione+Quad flash, Flash singolo ICAO / Single flash, Double flash, Quad flash, Quick flash, Rotating flash, Rotating + Quad flash, Single flash ICAO | 24 | IP67 | PC | -30°C a +60°C |
| 68613 | 3 | LED | Base flessi- bile / Flexi base | 12-24 | Flash singolo, Doppio flash, Quad flash, Flash veloce, Rotazio- ne, Rotazione+Quad flash, Flash singolo ICAO / Single flash, Double flash, Quad flash, Quick flash, Rotating flash, Rotating + Quad flash, Single flash ICAO | 24 | IP67 | PC | -30°C a +60°C |

LAMPEGGIANTE LED 12-24V, 25W, 50 LED

LED BEACON 12-24V, 25W, 50 LED
 GYROPHARE LED 12-24V, 25W, 50 LED
 RUNDUMLEUCHTE LED MIT FLEXIBLER BASIS 12-24V, 12W, 8 LED
 BALIZA LED 12-24V, 25W, 50 LED



1



2



3

Articoli a ricambio



04597

Cavo spiralato con spina ON/OFF e pulsante per selezionare il flash

ECE, CE, RoHS, CISPR 25 CLASSE 3, SAE-J845

| Skù | Pos. | Tipo luce / Light type | Linea / Line | Tensione nominale / Rated voltage | Funzioni / Functions | Numero led / Number of LEDs | Grado protezione ip / Degree of protection ip | Temperatura di esercizio / Operating temperature | Corpo faro / Light body | Materiale lente / Lens material |
|-------|------|------------------------|--------------------------------|-----------------------------------|--|-----------------------------|---|--|-------------------------|---------------------------------|
| 64495 | 1 | LED | Base piana / Bolt-on base | 12-24 V | 3 modalità flash e 4 modalità di rotazione / 3 flashing modes and 4 rotating modes | 50 | IP67 | -40° / +60° C | PC | PC |
| 64496 | 2 | LED | Base magnetica / Magnetic base | 12-24 V | 3 modalità flash e 4 modalità di rotazione / 3 flashing modes and 4 rotating modes | 50 | IP67 | -40° / +60° C | PC | PC |
| 64497 | 3 | LED | Base flex / Flexi base | 12-24 V | 3 modalità flash e 4 modalità di rotazione / 3 flashing modes and 4 rotating modes | 50 | IP67 | -40° / +60° C | PC | PC |

LAMPEGGIANTE LED BASE FLESSIBILE 12-24V, 12W, 8 LED

FLEXI DIN LED BEACON 12-24V, 12W, 8 LED
 GYROPHARE LED À BASE FLEXIBLE 12-24V, 12W, 8 LED
 RUNDUMLEUCHTE LED MIT FLEXIBLER BASIS 12-24V, 12W, 8 LED
 BALIZA LED CON BASE FLEXIBLE 12-24V, 12W, 8 LED



1



2

CE, RoHS, UKCA, CISPR 25 CLASSE 3

| Skù | Pos. | Tipo luce / Light type | Linea / Line | Tensione nominale / Rated voltage | Funzioni / Functions | Numero led / Number of LEDs | Grado protezione ip / Degree of protection ip | Temperatura di esercizio / Operating temperature | Corpo faro / Light body | Materiale lente / Lens material | Colore / Colour |
|-------|------|------------------------|------------------------|-----------------------------------|---|-----------------------------|---|--|-------------------------|---------------------------------|-----------------|
| 55415 | 1 | LED | Base flex / Flexi base | 12-24 V | Rotazione, Flash singolo, Doppio flash, Quad flash / Rotation, Single flash Double flash, Triple (Octa) flash | 12 | IP67 | -30° / +60° C | PC | PC | Verde / Green |
| 55416 | 2 | LED | Base flex / Flexi base | 12-24 V | Rotazione, Flash singolo, Doppio flash, Quad flash / Rotation, Single flash Double flash, Triple (Octa) flash | 12 | IP67 | -30° / +60° C | PC | PC | Rosso / Red |

GIROFARO A LED BLU, MAGNETICO 12-24V

MAGNETIC BLUE LED BEACON 12-24V
 GYROPHARE LED BLEU MAGNÉTIQUE 12-24V
 MAGNETISCHES BLAUES LED-GIROFARO 12-24V
 GIROFARO LED AZUL MAGNÉTICO 12-24V

1

2
Articoli a ricambio

04597

Cavo spiralato con spina ON/OFF e pulsante per selezionare il flash

| Skù | Pos. | Tipo luce / Light type | Linea / Line | Tensione nominale / Rated voltage | Funzioni / Functions | Numero led / Number of LEDs | Grado protezio- ne ip / Degree of protection ip | Temperatura di esercizio / Opera- ting temperature | Corpo faro / Light body | Materiale lente / Lens material |
|--------------|------|---------------------------|---|---|--|-----------------------------------|---|--|----------------------------|---------------------------------------|
| 63129 | 2 | LED | Base magnetica / Magnetic base | 12-24 V | Flash singolo, Doppio flash veloce, Doppio flash lento, Triplo flash, Quad flash, Mega flash, Rotazione/ Single flash, Double flash, Double flash - slow, Triple flash, Quad flash, Mega flash, Rotate. | 18 | IP67 | -30° / +60° C | PC | PC |
| 65142 | 1 | LED | Base flex / DIN pole mount | 12-24 V | Flash singolo, Doppio flash veloce, Doppio flash lento, Triplo flash, Quad flash, Mega flash, Rotazione/ 7 Flash pattern: Single fla- sh, Double flash, Double flash - slow, Triple flash, Quad flash, Mega flash, Rotate. | 18 | IP67 | -30° / +60° C | Flex | PC |

GIROFARI LED 12V, BASE AD ASTA FLESSIBILE, 36 LED

LED BEACON 12V, FLEXI DIN BASE, 36 LEDS
 GYROPHARE LED 12V, BASE FLEXI DIN, 36 LEDS
 LED-RUNDUMLEUCHTE 12V, FLEXI-DIN-BASIS, 36 LEDS
 BALIZA LED 12V, BASE FLEXI DIN, 36 LEDS

1

2

ECE, CE, RoHS, UKCA, CISPR 25 CLASSE 5, SAE CLASSE 2

| Skù | Pos. | Tipo luce / Light type | Linea / Line | Tensione nominale / Rated voltage | Funzioni / Functions | Numero led / Number of LEDs | Grado protezione ip / Degree of protection ip | Temperatura di esercizio / Operating temperature | Corpo faro / Light body | Materiale lente / Lens material |
|--------------|------|---------------------------|--|---|---------------------------------|--------------------------------|---|--|----------------------------|------------------------------------|
| 68160 | 1 | LED | Base flex / Flexi base | 12 V | Flash singolo / Single flash | 36 | IP67 | -40°/+70°C | ABSe FRB / ABS & FRP | PMMA |
| 68161 | 2 | LED | Base magneti- ca / Magnetic base | 12 V | Flash singolo / Single flash | 36 | IP67 | -40°/+70°C | ABS e FRP / ABS & FRP | PMMA |

GIROFARO LED 10-110V BASE PIANA

LED BEACON 10-110V, BOLT MOUNTING
 GYROPHARE LED 10-110V, FIXATION PAR BOULON
 LED-RUNDUMLEUCHTE 10-110V, SCHRAUBBEFESTIGUNG
 BALIZA LED 10-110V, MONTAJE CON PERNO



CE, RoHS, UKCA

| Skü | Tipo luce / Light type | Modello / Model | Tensione nominale / Rated voltage | Funzioni / Functions | Numero led / Number of LEDs | Grado protezione ip / Degree of protection ip | Temperatura di esercizio / Operating temperature | Materiale lente / Lens material | Corpo faro / Light body | Destinazione d'uso / Intended use | Omolo- gazioni Homolo- gations |
|-------|---------------------------|--------------------|---|-------------------------|--------------------------------------|--|---|---------------------------------------|-------------------------------|---|---|
| 65121 | LED | Base piana | 10-110 | Quad flash | 24 | IP67 | -30°C a +60°C | PC | PC | Carrelli elevatori, spazzatrici indu- striali, piattaforme aeree, piattaforme semoventi per raccolta frutta e altre macchine simili indoor / orklifts, industrial sweepers, aerial and fruit-pi- cking platforms, and similar indoor machines | ECE-R10 |

GIROFARO LED 10-110V BASE PIANA

LED BEACON 10-110V, BOLT MOUNTING
 GYROPHARE LED 10-110V, FIXATION PAR BOULON
 LED-RUNDUMLEUCHTE 10-110V, SCHRAUBBEFESTIGUNG
 BALIZA LED 10-110V, MONTAJE CON PERNO

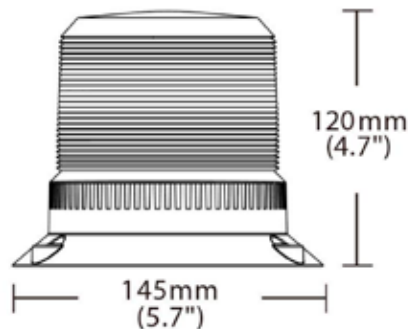

CE, RoHS, UKCA

| Skü | Modello / Model | Tensione nominale / Rated voltage | Funzioni / Functions | Numero led / Number of LEDs | Grado pro- tezione ip / Degree of protection ip | Temperatura di esercizio / Operating temperature | Materiale lente / Lens material | Corpo faro / Light body | Destinazione d'uso / Intended use | Omolo- gazioni Homolo- gations |
|-------|------------------------------|---|-------------------------|-----------------------------------|--|---|--|-------------------------------|--|---|
| 68470 | Base piana / Bolt-on base | 10-110 V | Quad flash | 24 | IP67 | -30°C a +60°C | PC | PC | Carrelli elevatori, spazzatrici industriali, piattafor- me aeree, piattaforme semoventi per raccolta frutta e altre macchine simili indoor / Forklifts, industrial sweepers, aerial and fruit-picking platforms, and similar indoor machines | ECE-R11 |

GIROFARI ALOGENI 12V E 24V

HALOGEN BEACON 12V AND 24V
 GYROPHARE HALOGÈNE 12V ET 24V
 RUNDUMLEUCHTE HALOGENE 12V UND 24V
 FARO DESTELLANTE HALÓGENO 12V Y 24V

1

2

3
Articoli a ricambio

| | | |
|--|--------------|--|
| | 63113 | Calotta ambra a ricambio 63110 - 63111 - 63112 |
| | 04593 | Cavo spiralato con spina agricola on/off |
| | 04594 | Spina agricola on/off |
| | 08048 | Lampadina alogena H1 12V55W P14,5s. |
| | 08049 | Lampadina alogena H1 24V 70W P14,5s |

ECE, CE, RoHS, UKCA, CISPR 25 CLASS

| Skù | Pos. | Tipo luce / Light type | Linea / Line | Tensione nominale / Rated voltage | Funzioni / Functions | Grado protezione ip / Degree of protection ip | Temperatura di esercizio / Operating temperature | Materiale lente / Lens material | Corpo faro / Light body | Omologazioni / Homologations |
|------------------|------|------------------------|--------------------------------|-----------------------------------|----------------------|---|--|---------------------------------|-------------------------|------------------------------|
| 63110 | 1 | Alogeno / Halogen | Base piana / Bolt-on base | 12 V | Rotazione / Rotation | IP67 | -30° / +60° C | PC | PC | ECE R10, ECE R65 |
| 63111 | 2 | Alogeno / Halogen | Base magnetica / Magnetic base | 12 V | Rotazione / Rotation | IP67 | -30° / +60° C | PC | PC | ECE R10, ECE R65 |
| 63112 | 3 | Alogeno / Halogen | Base flex / Flexi base | 12 V | Rotazione / Rotation | IP67 | -30° / +60° C | PC | PC | ECE R10, ECE R65 |
| 63110.24V | 1 | Alogeno / Halogen | Base piana / Bolt-on base | 24 V | Rotazione / Rotation | IP67 | -30° / +60° C | PC | PC | ECE R10, ECE R65 |
| 63111.24V | 2 | Alogeno / Halogen | Base magnetica / Magnetic base | 24 V | Rotazione / Rotation | IP67 | -30° / +60° C | PC | PC | ECE R10, ECE R65 |
| 63112.24V | 3 | Alogeno / Halogen | Base flex / Flexi base | 24 V | Rotazione / Rotation | IP67 | -30° / +60° C | PC | PC | ECE R10, ECE R65 |

GIROFARI LED DI EMERGENZA

EMERGENCY RECHARGEABLE MAGNETIC LED LIGHTS
 LAMPES LED D'URGENCE RECHARGEABLES ET MAGNÉTIQUES
 WIEDERAUFLADBARE MAGNETISCHE LED-NOTLEUCHTEN
 LUCES LED DE EMERGENCIA RECARGABLES Y MAGNÉTICAS



Articoli a ricambio



68133 Luce LED di emergenza magnetico e appendibile per kit 68132 68132

| Skù | Pos. | Tipo luce / Light type | Modello / Model | Tensione nominale / Rated voltage | Funzioni / Functions | Numero led / Number of LEDs | Note / Notes | Temperatura di esercizio / Operating temperature | Corpo faro / Light body | Materiale lente / Lens material | Destinazione d'uso / Intended use |
|-------|------|------------------------|--|-----------------------------------|--|--|---|--|---|---------------------------------|---|
| 68132 | 1 | LED | Base magnetica e gancio appendibile / Magnetic base and hanging hook | 12-24V | Rotazione, Quad flash, Flash singolo, Flash intermittente, SOS flash, Luce alta continua, Luce bassa continua, Flash 2 LED, Flash 4 LED, Luce da lavoro / Rotation, Quad flash, Single flash, Intermittent flash, SOS flash, High steady light, Low steady light, 2-LED flash, 4-LED flash, Work light | 16 arancioni, 3 bianchi / 16 orange LEDs, 3 white LEDs | Durata batteria 7 ore (con luce fissa), ricarica 3,5 ore / Battery life: 7 hours (with steady light), charging time: 3.5 hours | -30°C a +50°C | PC+gomma in silicone / PC + silicone rubber | ABS | Universale, luce di emergenza stradale, non per circolazione / Universal, road emergency light, not for circulation |
| 77006 | 2-3 | LED | Base magnetica / Magnetic base | 12-24V | Quintuplo flash arancione (V16-mercato spagnolo); Flash singolo arancione; Flash SOS arancione; Luce di lavoro bianca / Quintuple orange flash (V16 - Spanish market); Single orange flash; Orange SOS flash; White work light | 28 arancioni, 4 bianchi / 28 orange LED's, 4 white LED's | Durata batteria 4 ore, tempo di ricarica 3-4 ore / Battery life: 4 hours, charging time: 3-4 hours | -30°C a +50°C | ABS | PC | Universale, luce di emergenza stradale, non per circolazione / Universal, road emergency light, not for circulation |

LUCI DI SEGNALAZIONE LED ARANCIONE 12-24V

WARNING FLASH LAMPS ORANGE 12-24V
 LAMPES FLASH D'AVERTISSEMENT ORANGE 12-24V
 WARNBLITZLAMPEN ORANGE 12-24V
 LÁMPARAS DE DESTELLO DE ADVERTENCIA NARANJA 12-24V



1



2

ECE, CE, RoHS

| Skù | Pos. | Tipo luce / Light type | Tensione nominale / Rated voltage | Funzioni / Functions | Numero led / Number of LEDs | Colore / Colour | Grado protezione ip / Degree of protection ip | Temperatura di esercizio / Operating temperature | Corpo faro / Light body | Materiale lente / Lens material | Omologazioni Homologations |
|-------|------|------------------------|-----------------------------------|---|-----------------------------|--------------------|---|--|-------------------------|---------------------------------|----------------------------|
| 64468 | 1 | LED | 12-24 V | Flash singolo, Doppio flash veloce, Doppio flash lento, Triplo flash, Quad flash, Mega flash, Rotazione / Single flash, Double flash, Triple flash, Four flash, Steady burn flash | 3 | Arancione / Orange | IP67 | -40° / +65° C | Alluminio / Aluminium | PC | ECE R10, ECE R65 |
| 64469 | 2 | LED | 12-24 V | Flash singolo, Flash doppio, Triplo flash, Quad flash, Flash dinamico / Single flash, Double flash, Triple flash, Four flash, Single flash alt. left&right half, Double flash alt. left&right half, Triple flash alt. left&right half, Four flash alt. left&right half, Steady burn flash | 6 | Arancione / Orange | IP67 | -40° / +65° C | Alluminio / Aluminium | PC | ECE R10, ECE R65 |

LUCI DI SEGNALAZIONE LED ARANCIONE 12-24V

WARNING FLASH LAMPS ORANGE 12-24V

LAMPES FLASH D'AVERTISSEMENT ORANGE 12-24V

WARNBLITZLAMPEN ORANGE 12-24V

LÁMPARAS DE DESTELLO DE ADVERTENCIA NARANJA 12-24V

1

2

CE, RoHS

| Skü | Pos. | Tipo luce / Light type | Tensione nominale / Rated voltage | Funzioni / Functions | Numero led / Number of LEDs | Colore / Colour | Grado protezione ip / Degree of protection ip | Temperatura di esercizio / Operating temperature | Corpo faro / Light body | Materiale lente / Lens material | Omologazioni Homologations |
|--------------|------|------------------------|-----------------------------------|---------------------------------------|-----------------------------|--------------------|---|--|----------------------------|---------------------------------|----------------------------|
| 64493 | 1 | LED | 12-24 V | 26 modalità flash / 26 flash patterns | 3 | Arancione / Orange | IP67 | -30° / +60° C | PC/Alluminio / PC/Aluminum | PC | ECE R10, ECE R65 |
| 64494 | 2 | LED | 12-24 V | 26 modalità flash / 26 flash patterns | 4 | Arancione / Orange | IP67 | -30° / +60° C | PC/Alluminio / PC/Aluminum | PC | ECE R10, ECE R65 |

BARRA A LED CON CONTROLLER 12-24V

LED LIGHT BAR WITH CONTROLLER, 12-24V

RAMPE LED AVEC CONTRÔLEUR, 12-24V

LED-LEISTE MIT STEUERGERÄT, 12-24V

BARRA LED CON CONTROLADOR, 12-24V

1

2

3

| Skü | Pos. | Tipo luce / Light type | Modello / Model | Tensione nominale / Rated voltage | Potenza nominale / Rated power | Numero led / Number of LEDs | Funzioni / Functions | Colore / Colour | Lunghezza cavo / Cable length |
|--------------|------|------------------------|----------------------------------|-----------------------------------|--------------------------------|-----------------------------|------------------------------------|------------------------------|-------------------------------|
| 69410 | 1 | LED | con controller / with controller | 12-24 V DC | 85 W | 222 | 27 Modalità flash / 27 flash modes | Luce arancione / Amber light | 3,5 m + 3,5 m + 1,5 m |
| 69411 | 2 | LED | con controller / with controller | 12-24 V DC | 102 W | 282 | 27 Modalità flash / 27 flash modes | Luce arancione / Amber light | 3,5 m + 3,5 m + 1,5 m |
| 69412 | 3 | LED | con controller / with controller | 12-24 V DC | 117 W | 342 | 27 Modalità flash / 27 flash modes | Luce arancione / Amber light | 3,5 m + 3,5 m + 1,5 m |

BARRA A LED MAGNETICA 12-24V

MAGNETIC LED BAR 12-24V
 BARRE LED MAGNÉTIQUE 12-24V
 MAGNETISCHE LED-LEISTE 12-24V
 BARRA MAGNÉTICA LED 12-24V



ECE, CE, RoHS, CISPR 25 CLASSE 3

| Skü | Pos. | Tipo luce / Light type | Tensione nominale / Rated voltage | Materiale lente / Lens material | Corpo faro / Light body | Numero led / Number of LEDs | Collegamento elettrico / Electrical connection | Potenza nominale / Rated power | Grado protezio- ne ip / Degree of protection ip | Temperatura di esercizio / Opera- ting temperature | Funzioni / Functions |
|-------|------|---------------------------|---|---------------------------------------|---|-----------------------------------|--|--------------------------------------|---|--|--|
| 69400 | 1 | LED | 12-24 V | PC | PC e allumi- nio / PC&Alu- minium | 48 | Spina accendisigari / Cigarette lighter plug | 48 W | IP67 | -30°C; +60°C | 17 modalità fash / 17 flashing patterns |
| 69401 | 2 | LED | 12-24 V | PC | PC | 72 | Spina accendisigari / Cigarette lighter plug | 76 W | IP67 | -30°C; +60°C | 26 modalità flash / 26 flashing patterns |
| 69402 | 3 | LED | 12-24 V | PC | PC | 72 | Spina accendisigari / Cigarette lighter plug | 76 W | IP67 | -30°C; +60°C | 26 modalità flash / 26 flashing patterns |

CALOTTE A RICAMBIO

WARNING BEACON LENS
 LENTILLE DE GYROPHARES
 STREUSCHEIBE RUNDUMLEUCHTE
 TULIPAS PARA FAROS DESTELLANTE



| Skü | Pos. | Colore / Colour | Linea / Line | Diametro / Diameter |
|-------|------|--------------------|--------------------|---------------------|
| 03435 | 1 | arancione / orange | Serie Pulsar -Ajba | 127 mm |
| 34107 | 2 | arancione / orange | Serie One | 135 mm |

SPINA ACCENDISIGARI CON CAVO A SPIRALE

CIGAR PLUG WITH SPIRAL CABLE
 PRISE ALLUME-CIGARE AVEC CÂBLE SPIRALÉ
 STECKER ZIGARETTENANZÜNDER MIT SPIRALKABEL
 ENCHUFE DE MECHERO CON CABLE ESPIRAL



1

2

3

| Skü | Pos. | Lunghezza / Length | Modello / Model | Linea / Line |
|-------|------|--------------------|--|--|
| 04590 | 1 | 3,50 m | Presä accendisigari / Cigarette lighter socket | pulsante On/Off / On/Off button |
| 04593 | 2 | 3,50 m | Presä agricola / Agricultural plug | pulsante On/Off / On/Off button |
| 04597 | 3 | 3,50 m | Presä agricola / Agricultural plug | pulsante On/Off e pulsante per selezionare il flash / On/Off button and flash selection button |

SPINE ACCENDISIGARI

CIGAR PLUG
 PRISE ALLUME-CIGARE
 STECKER ZIGARETTENANZÜNDER
 ENCHUFE DE MECHERO



1

2

3

4

5

| Skü | Pos. | Modello / Model | Linea / Line |
|-------|------|--|---------------------------------|
| 04592 | 1 | Presä accendisigari / For cigarette lighter socket | Pulsante On/Off / On/Off button |
| 04594 | 2 | Presä agricola / Agricultural plug | Pulsante On/Off / On/Off button |
| 04596 | 3 | Adattatore spina accendisigari e spina agricola / Cigarette lighter to agricultural plug adapter | |
| 55444 | 4 | 2 poli / 2-pole | LED verde / Green LED |
| 55445 | 5 | 2 poli / 2-pole | |

KIT MAGNETICO

MAGNETIC KIT
 KIT MAGNETIQUE
 MAGNETISCHER SATZ
 KIT MAGNÉTICO



| Skü | Contenuto / Content |
|-------|--|
| 03426 | Magnete, cuffia, vite / Magnet, cap, screw |



PIANTONI PER GIROFARI

BEACON HOLDERS

SUPPORTS POUR GYROPHARE

HALTERUNGEN FÜR RUNDUMLEUCHTEN

SOPORTES PARA BALIZAS

| Skü | Fissaggio / Fastening | Collegamento elettrico / Electrical connection |
|-------|---|---|
| 55360 |  da saldare / to be soldered | presa con cavi 20 cm / connector with 20 cm wires |
| 55361 |  a vite / screw-fastened | presa con cavi 20 cm / connector with 20 cm wires |
| 55362 |  con staffa, inclinabile 90° / with bracket, adjustable up to 90° | presa con cavi 20 cm / connector with 20 cm wires |
| 55363 |  con staffa a T / with T-bracket | presa con cavi 20 cm / connector with 20 cm wires |
| 55364 |  con staffa laterale / with side bracket | presa con cavi 20 cm / connector with 20 cm wires |
| 55365 |  con staffa a L / with L-bracket | presa con cavi 20 cm / connector with 20 cm wires |
| 55366 |  con staffa, inclinabile 180° / with bracket, adjustable up to 180° | presa con cavi 20 cm / connector with 20 cm wires |
| 55367 |  con staffa lunga laterale / with long side bracket | presa con cavi 20 cm / connector with 20 cm wires |
| 76499 |  con staffa, inclinabile 360° / with bracket, adjustable up to 360° | presa / connector |

PIANTONE E SUPPORTO GIROFARI IN NYLON

BEACON POLE AND HOLDER IN NYLON
 TIGE ET SUPPORT DE GYROPHARE EN NYLON
 STANGE UND HALTERUNG FÜR RUNDUMLEUCHTE AUS NYLON
 PÉRTIGA Y SOPORTE PARA BALIZA EN NYLON



| Skü | Tipo / Type | Materiali / Material | Note / Notes |
|---------|-----------------|--|--|
| 0A27231 | piantone / pole | Nylon con fibra di vetro / Nylon with fiberglass | |
| 0A27232 | supporto / base | Nylon con fibra di vetro / Nylon with fiberglass | Permette una rotazione del piantone di 104° / Allows a pole rotation of 104° |

CAPPUCCIO DI PROTEZIONE PER SUPPORTI GIROFARI

RUBBER CAP BEACON BRACKET
 EMBOUT CAOUTCHOUC POUR SUPPORTS
 GUMMIKAPPE FÜR POLE BEACON HALTERUNGEN
 TAPA DE GOMA PARA SOPORTES



| Skü | Descrizione / Description |
|-------|---|
| 19412 | Tappo di protezione per piantoni girofari in PVC, il giunto con occhiello permette di fissare il coperchio al piantone / PVC protective cap for beacon poles, with eyelet joint to secure cover to pole |



Fari da lavoro

Work lights

I prodotti recanti il marchio AMA qui indicati sono realizzati da AMA S.p.A. e destinati a essere utilizzati come ricambi adattabili e non originali. I riferimenti a marchi, codici originali e costruttori di terzi, riportati in corrispondenza degli articoli AMA compatibili, hanno esclusivamente la finalità di identificare il modello, l'applicazione o la destinazione d'uso del prodotto, in conformità a quanto previsto dal Regolamento (CE) n. 1400/2002 e dalla normativa vigente in materia di concorrenza e uso lecito dei marchi di terzi. / The products bearing the AMA brand name listed here are manufactured by AMA S.p.A. and are intended for use as adaptable, non-original spare parts. References to trademarks, original codes and third-party manufacturers, shown alongside compatible AMA items, are intended solely to identify the model, application or intended use of the product, in accordance with Regulation (EC) No. 1400/2002 and current legislation on competition and the lawful use of third-party trademarks.

FARO LAVORO LED RETTANGOLARE 10-30V 3080 LM

RECTANGULAR LED WORK LIGHT 10-30V 3080 LM
 PHARE DE TRAVAIL LED RECTANGULAIRE 10-30V 3080 LM
 RECHTECKIGE LED-ARBEITSSCHEINWERFER 10-30V 3080 LM
 FARO DE TRABAJO LED RECTANGULAR 10-30V 3080 LM



CE, RoHS, REACH, CISPR 25 Classe 4

| Skü | Tensione nominale / Rated voltage | Potenza nominale / Rated power | Lumen | Flusso luminoso / Luminous flux | Numero led / Number of LEDs | Materiale lente / Lens material | Corpo fero / Light body | Collegamento elettrico / Electrical connection | Fissaggio / Fastening | Grado protezione ip / Degree of protection ip |
|--------------|-----------------------------------|--------------------------------|---------|---------------------------------|-----------------------------|---------------------------------|-------------------------|--|-----------------------|---|
| 65250 | 10-30 V / 10-30 V DC | 40 W | 3080 LM | Ampio/largo / Flood beam | 40 | PC | alluminio / aluminum | cavo 50 cm / cable 50 cm | Vite M8 / M8 screw | IP68 |

FARO LAVORO LED RETTANGOLARE 10-30V 4620 LM

RECTANGULAR LED WORK LIGHT 10-30V 4620 LM
 PHARE DE TRAVAIL LED RECTANGULAIRE 10-30V 4620 LM
 RECHTECKIGE LED-ARBEITSSCHEINWERFER 10-30V 4620 LM
 FARO DE TRABAJO LED RECTANGULAR 10-30V 4620 LM



CE, RoHS, REACH, CISPR 25 Classe 4

| Skü | Tensione nominale / Rated voltage | Potenza nominale / Rated power | Lumen | Flusso luminoso / Luminous flux | Numero led / Number of LEDs | Materiale lente / Lens material | Corpo fero / Light body | Collegamento elettrico / Electrical connection | Fissaggio / Fastening | Grado protezione ip / Degree of protection ip |
|--------------|-----------------------------------|--------------------------------|---------|---------------------------------|-----------------------------|---------------------------------|-------------------------|--|-----------------------|---|
| 65252 | 10-30 V / 10-30 V DC | 60 W | 4620 LM | Ampio/largo / Flood beam | 60 | PC | Alluminio / Aluminum | cavo 50 cm / cable 50 cm | Vite M10 / M10 screw | IP68 |

FARO LAVORO LED RETTANGOLARE 10-30V 12800 LM

RECTANGULAR LED WORK LIGHT 10-30V 12800 LM
 PHARE DE TRAVAIL LED RECTANGULAIRE 10-30V 12800 LM
 RECHTECKIGE LED-ARBEITSSCHEINWERFER 10-30V 12800 LM
 FARO DE TRABAJO LED RECTANGULAR 10-30V 12800 LM



CE, RoHS, REACH, CISPR 25 Classe 4

| Skü | Tensione nominale / Rated voltage | Potenza nominale / Rated power | Lumen | Flusso luminoso / Luminous flux | Numero led / Number of LEDs | Materiale lente / Lens material | Corpo fero / Light body | Collegamento elettrico / Electrical connection | Fissaggio / Fastening | Grado protezione ip / Degree of protection ip |
|--------------|-----------------------------------|--------------------------------|----------|---------------------------------|-----------------------------|---------------------------------|-------------------------|--|-----------------------|---|
| 65253 | 10-30 V / 10-30 V DC | 160 W | 12800 LM | Ampio/largo / Flood beam | 160 | PC | Alluminio / Aluminum | cavo 50 cm / cable 50 cm | Vite M10 / M10 screw | IP68 |

FARI DA LAVORO LED RETTANGOLARI 10-30V, RAGGIO COMBO

RECTANGULAR LED WORK LIGHTS 10-30V, COMBO BEAM
 PROJECTEURS DE TRAVAIL LED RECTANGULAIRES 10-30V, FAISCEAU COMBO
 RECHTECKIGE LED-ARBEITSSCHEINWERFER 10-30V, COMBO-LICHTSTRAHL
 FAROS DE TRABAJO LED RECTANGULARES 10-30V, HAZ COMBO



1



2

| Skü | Pos. | Tensione nominale / Rated voltage | Potenza nominale / Rated power | Lumen | Flusso luminoso / Luminous flux | Numero led / Number of LEDs | Materiale lente / Lens material | Corpo fero / Light body | Fissaggio / Fastening | Grado protezione ip / Degree of protection ip |
|-------|------|-----------------------------------|--------------------------------|-----------|---|-----------------------------|---------------------------------|-------------------------|-----------------------|---|
| 61081 | 1 | 10-30 V DC | 25 W | 2800 | Combo (ampio e profondo) / Combo beam (wide and long-range) | 30 | PC | Alluminio / Aluminium | Vite / Screw | IP67 |
| 61082 | 2 | 10-30 V DC | 25 W | 3375/2750 | Combo (ampio e profondo) / Combo beam (wide and long-range) | 18 Osram / 18 Osram LED's | PC | Alluminio / Aluminium | Vite / Screw | IP69K |

FARI DA LAVORO LED RETTANGOLARI

RECTANGULAR LED WORK LIGHTS
 PHARES DE TRAVAIL LED RECTANGULAIRES
 RECHTECKIGE LED-ARBEITSSCHEINWERFER
 FAROS DE TRABAJO LED RECTANGULARES



CE, RoHS, CISPR 25 Classe 3

| Skü | Tensione nominale / Rated voltage | Potenza nominale / Rated power | Lumen | Flusso luminoso / Luminous flux | Numero led / Number of LEDs | Materiale lente / Lens material | Corpo fero / Light body | Collegamento elettrico / Electrical connection | Fissaggio / Fastening | Grado protezione ip / Degree of protection ip |
|---------|-----------------------------------|--------------------------------|---------|---------------------------------|-----------------------------|---------------------------------|-------------------------|--|-----------------------|---|
| 0F01103 | 10-30 V | 18 W | 1080 LM | Ampio raggio (60°) / Flood beam | 6 | PC | Alluminio / Aluminium | Cavo 40-60 cm / Cable 40-60 cm | Vite M8 / M8 screw | IP67 |
| 61103 | 10-36 V | 18 W | 1350 LM | Ampio/largo / Flood beam | 6 | PMMA | Alluminio / Aluminium | Cavo 40 cm / Cable 40 cm | Vite M8 / M8 screw | IP67 |

FARO LAVORO LED RETTANGOLARE 10-36V, 50W, 4000LM

LED WORK LIGHT RECTANGULAR 10-36V, 50W, 4000LM
 PROJECTEUR DE TRAVAIL LED RECTANGULAIRE 10-36V, 50W, 4000LM
 RECHTECKIGER LED-ARBEITSSCHEINWERFER 10-36V, 50W, 4000LM
 FARO DE TRABAJO LED RECTANGULAR 10-36V, 50W, 4000LM



CE, RoHS, UKCA, CISPR 25 Classe 2

| Skü | Tensione nominale / Rated voltage | Potenza nominale / Rated power | Lumen | Flusso luminoso / Luminous flux | Numero led / Number of LEDs | Materiale lente / Lens material | Corpo fero / Light body | Collegamento elettrico / Electrical connection | Fissaggio / Fastening | Grado protezione ip / Degree of protection ip |
|-------|-----------------------------------|--------------------------------|---------|---------------------------------|-----------------------------|---------------------------------|-------------------------|--|-----------------------|---|
| 61118 | 10-36 V | 50 W | 4000 LM | Ampio/largo / Flood beam | 5 | PMMA | Alluminio / Aluminium | Cavo 38 cm / Cable 38 cm | Vite M8 / M8 screw | IP67 |

FARO DA LAVORO RETTANGOLARE LED 10-30V 2850LM RAGGIO COMBO

RECTANGULAR LED WORK LIGHT 10-30V 2850LM COMBO BEAM
 PHARE DE TRAVAIL LED RECTANGULAIRE 10-30V 2850LM FAISCEAU COMBO
 RECHTECKIGER LED-ARBEITSSCHEINWERFER 10-30V 2850LM COMBO-STRAHL
 LUZ DE TRABAJO LED RECTANGULAR 10-30V 2850LM HAZ COMBO



CE, RoHS, REACH, CISPR 25 Classe 3

| Skù | Tensione nominale / Rated voltage | Potenza nominale / Rated power | Lumen | Flusso luminoso / Luminous flux | Numero led / Number of LEDs | Materiale lente / Lens material | Corpo faro / Light body | Collegamento elettrico / Electrical connection | Fissaggio / Fastening | Grado protezione ip / Degree of protection ip |
|-------|-----------------------------------|--------------------------------|---------|---------------------------------|-----------------------------|---------------------------------|-------------------------|--|-----------------------|---|
| 64499 | 10-30 V | 22,5 W | 2850 LM | COMBO (ampio e lungo) / COMBO | 15 | PMMA | Alluminio / Aluminum | Cavo 30 cm / Cable 30 cm | Vite M8 / M8 screw | IP67, IP69K |

FARO LAVORO LED RETTANGOLARE 10-36V, 36W, 2800 LM

LED WORK LIGHT RECTANGULAR 10-36V, 36W, 2800LM
 PROJECTEUR DE TRAVAIL LED RECTANGULAIRE 10-36V, 36W, 2800LM
 LED-ARBEITSLUCHTE RECHTECK 10-36V, 36W, 2800LM
 FARO DE TRABAJO LED RECTANGULAR 10-36V, 36W, 2800LM



CE, RoHS, CISPR 25 Classe 2

| Skù | Tensione nominale / Rated voltage | Potenza nominale / Rated power | Lumen | Flusso luminoso / Luminous flux | Numero led / Number of LEDs | Materiale lente / Lens material | Corpo faro / Light body | Collegamento elettrico / Electrical connection | Fissaggio / Fastening | Grado protezione ip / Degree of protection ip |
|-------|-----------------------------------|--------------------------------|---------|--|-----------------------------|---------------------------------|-------------------------|--|-----------------------|---|
| 64479 | 10-36 V | 36 W | 2800 LM | COMBO (ampio e lungo) / Combo (Flood&Spot) | 12 | PMMA | Alluminio / Aluminium | Cavo 40 cm / Cable 40 cm | Vite M8 / M8 screw | IP67 |

FARO LAVORO LED RETTANGOLARE 12-28V, 1350LM INTERRUPTORE, ATTACCO A MAGNETE E SPINA ACCENDISIGARI

RECTANGULAR LED WORK LIGHT 12-28V, 1350LM WITH SWITCH, MAGNETIC MOUNT, AND CIGARETTE LIGHTER PLUG
 PHARE DE TRAVAIL LED RECTANG. 12-28V, 1350LM AV. INTERRUPTEUR, FIXATION MAGNÉTIQUE ET PRISE ALL
 RECHTECKIGER LED-ARBEITSSCHEINWERFER 12-28V, 1350LM MIT SCHALTER, MAGNETBEFESTIGUNG UND ZIGARETTENAN
 LUZ DE TRABAJO LED RECTANGULAR 12-28V, 1350LM CON INTERRUPTOR, SOPORTE MAGNÉTICO Y ENCHUFE DE ENCEND

Articoli a ricambio

| | | |
|--|--------------|-------------------------|
| | 04594 | Spina agricola on/off |
| | 55444 | Spina accendisigari 12V |
| | 55445 | Spina accendisigari |

CE, RoHS, CISPR 25 Classe 3

| Skù | Tensione nominale / Rated voltage | Potenza nominale / Rated power | Lumen | Flusso luminoso / Luminous flux | Numero led / Number of LEDs | Materiale lente / Lens material | Corpo faro / Light body | Collegamento elettrico / Electrical connection | Fissaggio / Fastening | Grado protezione ip / Degree of protection ip | Note / Notes |
|-------|-----------------------------------|--------------------------------|---------|---------------------------------|-----------------------------|---------------------------------|------------------------------|---|-----------------------|---|--|
| 64521 | 12-28 V | 18 W | 1350 LM | Ampio/largo / Flood beam | 6 | PC | Alluminio / Aluminum housing | Cavo spirale 9000 mm con spina agricola / Coiled power cable 9000 mm with agri-plug | Magnetico / Magnetic | IP67 | Interruttore impermeabile / With waterproof switch |

FARO LAVORO LED RETTANGOLARE 10-30V 3465 LM

RECTANGULAR LED WORK LIGHT 10-30V 3465 LM
 PHARE DE TRAVAIL LED RECTANGULAIRE 10-30V 3465 LM
 RECHTECKIGE LED-ARBEITSSCHEINWERFER 10-30V 3465 LM
 FARO DE TRABAJO LED RECTANGULAR 10-30V 3465 LM



CE, RoHS, REACH, CISPR 25 Classe 4

| Skü | Tensione nominale / Rated voltage | Potenza nominale / Rated power | Lumen | Flusso luminoso / Luminous flux | Numero led / Number of LEDs | Materiale lente / Lens material | Corpo faro / Light body | Collegamento elettrico / Electrical connection | Fissaggio / Fastening | Grado protezione ip / Degree of protection ip |
|--------------|-----------------------------------|--------------------------------|---------|---------------------------------|-----------------------------|---------------------------------|-------------------------|--|-----------------------|---|
| 65251 | 10-30 V / 10-30 V DC | 45 W | 3465 LM | Ampio/largo / Flood beam | 45 | PC | alluminio / aluminum | cavo 50 cm / cable 50 cm | Vite M8 / M8 screw | IP68 |

FARO LAVORO LED 10-36V, 2600 LM, LUCE AMPIA 240°

LED WORK LIGHT 10-36V, 2600 LM, 240° FLOOD BEAM
 PHARE DE TRAVAIL LED 10-36V, 2600 LM, FAISCEAU LARGE 240°
 LED-ARBEITSSCHEINWERFER 10-36V, 2600LM, 240° FLUTLICHT
 FARO DE TRABAJO LED 10-36V, 2600 LM, HAZ AMPLIO DE 240°



| Skü | Tensione nominale / Rated voltage | Potenza nominale / Rated power | Lumen | Flusso luminoso / Luminous flux | Numero led / Number of LEDs | Materiale lente / Lens material | Corpo faro / Light body | Collegamento elettrico / Electrical connection | Fissaggio / Fastening | Grado protezione ip / Degree of protection ip |
|--------------|-----------------------------------|--------------------------------|---------|---------------------------------|-----------------------------|---------------------------------|-------------------------|--|-----------------------|---|
| 65271 | 10-36 V | 36 W | 2600 LM | Ampio/largo 240° | 12/ | PC | alluminio / aluminum | cavo 37 cm / 240° Flood beam | Vite M8 / M8 screw | IP67 |

BARRA LUCE DA LAVORO LED 10-36V 1260LM

LED WORK LIGHT BAR 10-36V 1260LM
 BARRE LUMINEUSE LED 10-36V 1260LM
 LICHTLEISTE LED 10-36V 1260LM
 BARRA DE LUCES DE TRABAJO LED 10-36V 1260LM



CE, RoHS, CISPR 25 Classe 3

| Skü | Tensione nominale / Rated voltage | Potenza nominale / Rated power | Lumen | Flusso luminoso / Luminous flux | Numero led / Number of LEDs | Materiale lente / Lens material | Corpo faro / Light body | Collegamento elettrico / Electrical connection | Fissaggio / Fastening | Grado protezione ip / Degree of protection ip |
|--------------|-----------------------------------|--------------------------------|---------|---------------------------------|-----------------------------|---------------------------------|-------------------------|--|-----------------------|---|
| 64431 | 10-36 V | 18 W | 1260 LM | Lungo/profondo / Spot beam | 6 | PMMA | Alluminio / Aluminum | Cavo 40 cm / Cable 40 cm | Vite M8 / M8 screw | IP67 |

BARRA LUCE DA LAVORO LED 10-36V 1710LM

LED WORK LIGHT BAR 10-36V 1710LM

BARRE LUMINEUSE LED 10-36V 1710LM

LICHTLEISTE LED 10-36V 1710LM

BARRA DE LUCES DE TRABAJO LED 10-36V 1710LM



CE, RoHS, CISPR 25 Classe 3

| Skü | Tensione nominale / Rated voltage | Potenza nominale / Rated power | Lumen | Flusso luminoso / Luminous flux | Numero led / Number of LEDs | Materiale lente / Lens material | Corpo fero / Light body | Collegamento elettrico / Electrical connection | Fissaggio / Fastening | Grado protezione ip / Degree of protection ip |
|--------------|-----------------------------------|--------------------------------|---------|---------------------------------|-----------------------------|---------------------------------|-------------------------|--|-----------------------|---|
| 63760 | 10-36 V | 30 W | 1710 LM | Lungo/profondo / Spot beam | 6 | PMMA | Alluminio / Aluminim | Cavo 40 cm / Cable 40 cm | 2 staffe / 2 brackets | IP67 |
| 67409 | 10-36 V | 30 W | 1710 LM | Ampio/largo / Flood beam | 6 | PMMA | Alluminio / Aluminium | Cavo 40 cm / Cable 40 cm | 2 staffe / 2 brackets | IP67 |

FARO LAVORO LED ROTONDO 10-30V 5120 LM

ROUND LED WORK LIGHTS 10-30V 5120 LM

PHARE DE TRAVAIL LED ROND 10-30V 5120 LM

RUNDER LED-ARBEITSSCHEINWERFER 10-30V 5120 LM

FARO DE TRABAJO LED REDONDO 10-30V 5120 LM



CE, RoHS, REACH, CISPR 25 Classe 4

| Skü | Tensione nominale / Rated voltage | Potenza nominale / Rated power | Lumen | Flusso luminoso / Luminous flux | Numero led / Number of LEDs | Materiale lente / Lens material | Corpo fero / Light body | Collegamento elettrico / Electrical connection | Fissaggio / Fastening | Grado protezione ip / Degree of protection ip |
|--------------|-----------------------------------|--------------------------------|---------|---------------------------------|-----------------------------|---------------------------------|-------------------------|--|-----------------------|---|
| 65254 | 10-30 V / 10-30 VDC | 64 W | 5120 LM | Ampio/largo / Flood beam | 64 | PC | alluminio / aluminum | cavo 50 cm / cable 50 cm | Vite M8 / M8 screw | IP68 |

FARO LAVORO LED 10-30V ROTONDO 6400 LM

ROUND LED WORK LIGHTS 10-30V 6400 LM

PHARE DE TRAVAIL LED ROND 10-30V 6400 LM

RUNDER LED-ARBEITSSCHEINWERFER 10-30V 6400 LM

FARO DE TRABAJO LED REDONDO 10-30V 6400 LM



CE, RoHS, REACH, CISPR 25 Classe 4

| Skü | Tensione nominale / Rated voltage | Potenza nominale / Rated power | Lumen | Flusso luminoso / Luminous flux | Numero led / Number of LEDs | Materiale lente / Lens material | Corpo fero / Light body | Collegamento elettrico / Electrical connection | Fissaggio / Fastening | Grado protezione ip / Degree of protection ip |
|--------------|-----------------------------------|--------------------------------|---------|---------------------------------|-----------------------------|---------------------------------|-------------------------|--|-----------------------|---|
| 65255 | 10-30 V / 10-30 VDC | 80 W | 6400 LM | Ampio/largo / Flood beam | 80 | PC | alluminio / aluminum | cavo 50 cm / cable 50 cm | Vite M10 / M10 screw | IP68 |

FARO LAVORO LED ROTONDO 10-30V 8000 LM

ROUND LED WORK LIGHTS 10-30V 8000 LM

PHARE DE TRAVAIL LED ROND 10-30V 8000 LM

RUNDER LED-ARBEITSSCHEINWERFER 10-30V 8000 LM

FARO DE TRABAJO LED REDONDO 10-30V 8000 LM



CE, RoHS, REACH, CISPR 25 Classe 4

| Skü | Tensione nominale / Rated voltage | Potenza nominale / Rated power | Lumen | Flusso luminoso / Luminous flux | Numero led / Number of LEDs | Materiale lente / Lens material | Corpo fero / Light body | Collegamento elettrico / Electrical connection | Fissaggio / Fastening | Grado protezione ip / Degree of protection ip |
|-------|--------------------------------------|-----------------------------------|---------|------------------------------------|--------------------------------|------------------------------------|----------------------------|---|--------------------------|--|
| 65256 | 10-30 V / 10-30 V DC | 100 W | 8000 LM | Ampio/largo / Flood beam | 100 | PC | alluminio / aluminum | cavo 50 cm / cable 50 cm | Vite M10 / M10 screw | IP68 |

FARO LAVORO LED ROTONDO 10-30V 11520 LM

ROUND LED WORK LIGHTS 10-30V 11520 LM

PHARE DE TRAVAIL LED ROND 10-30V 11520 LM

RUNDER LED-ARBEITSSCHEINWERFER 10-30V 11520 LM

FARO DE TRABAJO LED REDONDO 10-30V 11520 LM



CE, RoHS, REACH, CISPR 25 Classe 4

| Skü | Tensione nominale / Rated voltage | Potenza nominale / Rated power | Lumen | Flusso luminoso / Luminous flux | Numero led / Number of LEDs | Materiale lente / Lens material | Corpo fero / Light body | Collegamento elettrico / Electrical connection | Fissaggio / Fastening | Grado protezione ip / Degree of protection ip |
|-------|--------------------------------------|-----------------------------------|----------|------------------------------------|--------------------------------|------------------------------------|----------------------------|---|--------------------------|--|
| 65257 | 10-30 V | 144 W | 11520 LM | Ampio/largo / Flood beam | 144 | PC | alluminio / aluminum | cavo 50 cm / cable 50 cm | Vite M10 / M10 screw | IP68 |

FARO LAVORO A LED ROTONDO 10-30V, 4500 LM, AMPIO RAGGIO (90°)

ROUND LED WORK LIGHT, 10-30V, 4500 LM, FLOOD BEAM (90°)

PROJECTEUR DE TRAVAIL LED ROND, 10-30V, 4500 LM, FAISCEAU LARGE (90°)

RUNDER LED-ARBEITSSCHEINWERFER, 10-30V, 4500 LM, BREITER LICHTSTRAHL (90°)

FARO DE TRABAJO LED REDONDO, 10-30V, 4500 LM, HAZ AMPLIO (90°)



| Skü | Tensione nominale / Rated voltage | Potenza nominale / Rated power | Lumen | Flusso luminoso / Luminous flux | Numero led / Number of LEDs | Materiale lente / Lens material | Corpo fero / Light body | Collegamento elettrico / Electrical connection | Fissaggio / Fastening | Grado protezione ip / Degree of protection ip |
|-------|--------------------------------------|-----------------------------------|---------|-------------------------------------|--------------------------------|------------------------------------|----------------------------|--|--------------------------|--|
| 65088 | 10-30 V DC | 28 W | 4500 LM | Ampio/largo 90° / 90° Flood beam | 15 | PC | alluminio / aluminum | Cavo 18 cm + connettore H11 / Cable 18 cm + H11 connector | M10 | IP69K |

FARI DA LAVORO LED ROTONDI

ROUND LED WORK LIGHTS
 PHARES DE TRAVAIL LED ROUNDS
 RUNDE LED-ARBEITSSCHEINWERFER
 FAROS DE TRABAJO LED REDONDOS



CE, RoHS, CISPR 25 Classe 3

| Skü | Tensione nominale / Rated voltage | Potenza nominale / Rated power | Lumen | Flusso luminoso / Luminous flux | Numero led / Number of LEDs | Materiale lente / Lens material | Corpo fero / Light body | Collegamento elettrico / Electrical connection | Fissaggio / Fastening | Grado protezione ip / Degree of protection ip |
|----------------|-----------------------------------|--------------------------------|--------|---------------------------------|-----------------------------|---------------------------------|-------------------------|--|-----------------------|---|
| 0F01106 | 12-24 V | 12 W | 720 LM | Ampio/largo / Flood beam | 4 | PC | Alluminio / Aluminium | Cavo 40-60 cm / Cable 40-60 cm | Vite M10 / M10 screw | IP67 |
| 61106 | 10-36 V | 12 W | 900 | Ampio/largo / Flood beam | 4 | PC | Alluminio / Aluminium | Cavo 40 cm / Cable 40 cm | Vite M8 / M8 screw | IP67 |

FARO DA LAVORO ROTONDO LED 12-24V 1350LM

ROUND LED WORK LIGHT 12-24V 1350LM
 PHARE DE TRAVAIL LED ROND 12-24V 1350LM
 RUNDER LED-ARBEITSSCHEINWERFER 12-24V 1350LM
 LUZ DE TRABAJO LED REDONDO 12-24V 1350LM



| Skü | Tensione nominale / Rated voltage | Potenza nominale / Rated power | Lumen | Flusso luminoso / Luminous flux | Numero led / Number of LEDs | Materiale lente / Lens material | Corpo fero / Light body | Collegamento elettrico / Electrical connection | Fissaggio / Fastening | Grado protezione ip / Degree of protection ip |
|----------------|-----------------------------------|--------------------------------|---------|---------------------------------|-----------------------------|---------------------------------|-------------------------|--|-----------------------|---|
| 0F01107 | 12-24 V | 18 W | 1350 LM | Ampio/largo / Flood beam | 6 | PMMA | Alluminio / Aluminium | Cavo 40-60 cm / Cable 40-60 cm | Vite M10 / M10 screw | IP67 |

FARI DA LAVORO LED ROTONDI

ROUND LED WORK LIGHTS
 PHARES DE TRAVAIL LED ROUNDS
 RUNDE LED-ARBEITSSCHEINWERFER
 FAROS DE TRABAJO LED REDONDOS



CE, RoHS, REACH, UKCA, CISPR 25 Classe 5

| Skü | Tensione nominale / Rated voltage | Potenza nominale / Rated power | Lumen | Flusso luminoso / Luminous flux | Numero led / Number of LEDs | Materiale lente / Lens material | Corpo fero / Light body | Collegamento elettrico / Electrical connection | Fissaggio / Fastening | Grado protezione ip / Degree of protection ip |
|--------------|-----------------------------------|--------------------------------|---------|---------------------------------|-----------------------------|---------------------------------|-------------------------|--|-----------------------|---|
| 61093 | 10-36 V | 27 W | 2025 LM | Ampio/largo / Flood beam | 9 | PMMA | Alluminio / Aluminium | Cavo 65 cm / Cable 65 cm | Vite M8 / M8 screw | IP67 |

FARI LAVORO LED TONDO 10-30V, 42W, 3150LM

LED WORK LIGHT ROUND 10-30V, 42W, 3150LM
 PROJECTEUR DE TRAVAIL LED ROND 10-30V, 42W, 3150LM
 LED-ARBEITSSCHEINWERFER RUND 10-30V, 42W, 3150LM
 FARO DE TRABAJO LED REDONDO 10-30V, 42W, 3150LM



CE, RoHS, CISPR 25 Classe 3

| Skü | Tensione nominale / Rated voltage | Potenza nominale / Rated power | Lumen | Flusso luminoso / Luminous flux | Numero led / Number of LEDs | Materiale lente / Lens material | Corpo fero / Light body | Collegamento elettrico / Electrical connection | Fissaggio / Fastening | Grado protezione ip / Degree of protection ip |
|-------|-----------------------------------|--------------------------------|---------|---------------------------------|-----------------------------|---------------------------------|-------------------------|--|-----------------------|---|
| 61117 | 10-36 V | 42 W | 3150 LM | Ampio/largo / Flood beam | 14 | PMMA | Alluminio / Aluminium | Cavo 40 cm / Cable 40 cm | Vite M8 / M8 screw | IP67 |

FARO DA LAVORO ROTONDO LED 12-28V 4050LM, CON INTERRUOTORE E MANIGLIA

ROUND LED WORK LIGHT 12-28V 4050LM, WITH SWITCH AND HANDLE
 PHARE DE TRAVAIL ROND LED 12-28V 4050LM, AVEC INTERRUPTEUR ET POIGNÉE
 RUNDER LED-ARBEITSSCHEINWERFER 12-28V 4050LM, MIT SCHALTER UND GRIFF
 FARO DE TRABAJO REDONDO LED 12-28V 4050LM, CON INTERRUPTOR Y ASA



CE, RoHS, CISPR 25 Classe 2

| Skü | Tensione nominale / Rated voltage | Potenza nominale / Rated power | Lumen | Flusso luminoso / Luminous flux | Numero led / Number of LEDs | Materiale lente / Lens material | Corpo fero / Light body | Collegamento elettrico / Electrical connection | Fissaggio / Fastening | Grado protezione ip / Degree of protection ip | Note / Notes |
|-------|-----------------------------------|--------------------------------|---------|---------------------------------|-----------------------------|---------------------------------|-------------------------|--|-----------------------|---|--------------------------------|
| 64488 | 12-28 V | 36 W | 4050 LM | Ampio/largo / Flood beam | 12 | PMMA | Alluminio / Aluminium | Cavo 2 m / Cable 2 m | Vite M10 / M10 screw | IP67 | con interruttore / with switch |
| 64489 | 12-28 V | 36 W | 4050 LM | Lungo/profondo / Spot beam | 12 | PMMA | Alluminio / Aluminium | Cavo 2 m / Cable 2 m | Vite M10 / M10 screw | IP67 | con interruttore / with switch |

FARO LAVORO LED QUADRATO 10-30V 5120 LM

SQUARE LED WORK LIGHT 10-30V 5120 LM
 PHARE DE TRAVAIL LED CARRÉ 10-30V 5120 LM
 QUADRATISCHER LED-ARBEITSSCHEINWERFER 10-30V 5120 LM
 FARO DE TRABAJO LED CUADRADO 10-30V 5120 LM



CE, RoHS, REACH, CISPR 25 Classe 4

| Skü | Tensione nominale / Rated voltage | Potenza nominale / Rated power | Lumen | Flusso luminoso / Luminous flux | Numero led / Number of LEDs | Materiale lente / Lens material | Corpo fero / Light body | Collegamento elettrico / Electrical connection | Fissaggio / Fastening | Grado protezione ip / Degree of protection ip |
|-------|-----------------------------------|--------------------------------|---------|---------------------------------|-----------------------------|---------------------------------|-------------------------|--|-----------------------|---|
| 65258 | 10-30 V / 10-30 VDC | 64 W | 5120 LM | Ampio/largo / Flood beam | 64 | PC | alluminio / aluminium | cavo 50 cm / cable 50 cm | Vite M8 / M8 screw | IP68 |

FARO LAVORO LED QUADRATO 10-30V 6400 LM

SQUARE LED WORK LIGHT 10-30V 6400 LM
 PHARE DE TRAVAIL LED CARRÉ 10-30V 6400 LM
 QUADRATISCHER LED-ARBEITSSCHEINWERFER 10-30V 6400 LM
 FARO DE TRABAJO LED CUADRADO 10-30V 6400 LM



CE, RoHS, REACH, CISPR 25 Classe 4

| Skü | Tensione nominale / Rated voltage | Potenza nominale / Rated power | Lumen | Flusso luminoso / Luminous flux | Numero led / Number of LEDs | Materiale lente / Lens material | Corpo fero / Light body | Collegamento elettrico / Electrical connection | Fissaggio / Fastening | Grado protezione ip / Degree of protection ip |
|--------------|--------------------------------------|-----------------------------------|---------|------------------------------------|--------------------------------|------------------------------------|----------------------------|---|--------------------------|--|
| 65259 | 10-30 V / 10-30 V DC | 80 W | 6400 LM | Ampio/largo / Flood beam | 80 | PC | alluminio / aluminum | cavo 50 cm / cable 50 cm | Vite M10 / M10 screw | IP68 |

FARO LAVORO LED QUADRATO 10-30V 8000 LM

SQUARE LED WORK LIGHT 10-30V 8000 LM
 PHARE DE TRAVAIL LED CARRÉ 10-30V 8000 LM
 QUADRATISCHER LED-ARBEITSSCHEINWERFER 10-30V 8000 LM
 FARO DE TRABAJO LED CUADRADO 10-30V 8000 LM



CE, RoHS, REACH, CISPR 25 Classe 4

| Skü | Tensione nominale / Rated voltage | Potenza nominale / Rated power | Lumen | Flusso luminoso / Luminous flux | Numero led / Number of LEDs | Materiale lente / Lens material | Corpo fero / Light body | Collegamento elettrico / Electrical connection | Fissaggio / Fastening | Grado protezione ip / Degree of protection ip |
|--------------|--------------------------------------|-----------------------------------|---------|------------------------------------|--------------------------------|------------------------------------|----------------------------|---|--------------------------|--|
| 65260 | 10-30 V / 10-30 V DC | 100 W | 8000 LM | Ampio/largo / Flood beam | 100 | PC | alluminio / aluminum | cavo 50 cm / cable 50 cm | Vite M10 / M10 screw | IP68 |

FARO LAVORO LED QUADRATO 10-30V 11520 LM

SQUARE LED WORK LIGHT 10-30V 11520 LM
 PHARE DE TRAVAIL LED CARRÉ 10-30V 11520 LM
 QUADRATISCHER LED-ARBEITSSCHEINWERFER 10-30V 11520 LM
 FARO DE TRABAJO LED CUADRADO 10-30V 11520 LM



CE, RoHS, REACH, CISPR 25 Classe 4

| Skü | Tensione nominale / Rated voltage | Potenza nominale / Rated power | Lumen | Flusso luminoso / Luminous flux | Numero led / Number of LEDs | Materiale lente / Lens material | Corpo fero / Light body | Collegamento elettrico / Electrical connection | Fissaggio / Fastening | Grado protezione ip / Degree of protection ip |
|--------------|--------------------------------------|-----------------------------------|----------|------------------------------------|--------------------------------|------------------------------------|----------------------------|---|--------------------------|--|
| 65261 | 10-30 V / 10-30 V DC | 144 W | 11520 LM | Ampio/largo / Flood beam | 144 | PC | alluminio / aluminum | cavo 50 cm / cable 50 cm | Vite M10 / M10 screw | IP68 |

FARO LAVORO LED QUADRATO 10-36V, 27W, 2025LM

LED WORK LIGHT SQUARE 10-36V, 27W, 2025LM
 PROJECTEUR DE TRAVAIL LED CARRÉ 10-36V, 27W, 2025LM
 LED-ARBEITSSCHEINWERFER QUADRATISCH 10-36V, 27W, 2025LM
 FARO DE TRABAJO LED CUADRADO 10-36V, 27W, 2025LM



CE, RoHS, REACH, CISPR 25 Classe 5

| Skü | Tensione nominale / Rated voltage | Potenza nominale / Rated power | Lumen | Flusso luminoso / Luminous flux | Numero led / Number of LEDs | Materiale lente / Lens material | Corpo fero / Light body | Collegamento elettrico / Electrical connection | Fissaggio / Fastening | Grado protezione ip / Degree of protection ip |
|--------------|-----------------------------------|--------------------------------|---------|---------------------------------|-----------------------------|---------------------------------|-------------------------|--|-----------------------|---|
| 61094 | 10-36 V | 27 W | 2025 LM | Ampio/largo / Flood beam | 9 | PMMA | Alluminio / Aluminium | Cavo 65 cm / Cable 65 cm | Vite M8 / M8 screw | IP67 |

FARO LAVORO A LED QUADRATO 10-110V DC, 27W, 2160LM

LED WORK LIGHT SQUARE 10-110V DC, 27W, 2160LM
 PROJECTEUR DE TRAVAIL LED CARRÉ 10-110V DC, 27W, 2160LM
 LED-ARBEITSLEUCHTE QUADRAT 10-110V DC, 27W, 2160LM
 FARO DE TRABAJO LED CUADRADO 10-110V DC, 27W, 2160LM



CE, RoHS, CISPR 25 Classe 4

| Skü | Tensione nominale / Rated voltage | Potenza nominale / Rated power | Lumen | Flusso luminoso / Luminous flux | Numero led / Number of LEDs | Materiale lente / Lens material | Corpo fero / Light body | Collegamento elettrico / Electrical connection | Fissaggio / Fastening | Grado protezione ip / Degree of protection ip |
|--------------|-----------------------------------|--------------------------------|---------|---------------------------------|-----------------------------|---------------------------------|-------------------------|--|-----------------------|---|
| 68053 | 10-110 V | 27 W | 2160 LM | Ampio/largo / Flood beam | 9 | PMMA | Alluminio / Aluminium | Cavo 20 cm / Cable 20 cm | Vite M8 / M8 screw | IP68, IP69K |

FARO LAVORO LED QUADRATO 10-32V, 20W, 1800LM

LED WORK LIGHT SQUARE 10-32V, 20W, 1800LM
 PROJECTEUR DE TRAVAIL LED CARRÉ 10-32V, 20W, 1800LM
 LED-ARBEITSLEUCHTE QUADRAT 10-32V, 20W, 1800LM
 FARO DE TRABAJO LED CUADRADO 10-32V, 20W, 1800LM



ECE, CE, RoHS, CISPR 25 Classe 3

| Skü | Tensione nominale / Rated voltage | Potenza nominale / Rated power | Lumen | Flusso luminoso / Luminous flux | Numero led / Number of LEDs | Materiale lente / Lens material | Corpo fero / Light body | Collegamento elettrico / Electrical connection | Fissaggio / Fastening | Grado protezione ip / Degree of protection ip |
|--------------|-----------------------------------|--------------------------------|-------|---------------------------------|-----------------------------|---------------------------------|-------------------------|--|-----------------------|---|
| 68051 | 10-32 V | 20 W | 1800 | Ampio/largo / Flood beam | 4 | PMMA | Alluminio / Aluminium | Cavo elettrico 60 cm / Cable 60 cm | Vite M8 / M8 screw | IP67 |

FARI LAVORO LED QUADRATI 10-30V

SQUARE LED WORK LIGHTS 10-30V
 PHARE DE TRAVAIL LED CARRÉ 10-30V
 QUADRATISCHE LED-ARBEITSLEUCHTEN 10-30V
 FAROS DE TRABAJO LED CUADRADOS 10-30V

1

2

3

ECE, CE, RoHS, UKCA, CISPR 25 Classe 4

| Skü | Pos. | Tensione nominale / Rated voltage | Potenza nominale / Rated power | Lumen | Flusso luminoso / Luminous flux | Numero led / Number of LEDs | Materiale lente / Lens material | Corpo faro / Light body | Collegamento elettrico / Electrical connection | Fissaggio / Fastening | Grado protezione ip / Degree of protection ip | Note / Notes |
|--------------|------|-----------------------------------|--------------------------------|-------|---------------------------------|-----------------------------|---------------------------------|-------------------------|--|-----------------------|---|--------------------------------|
| 48048 | 1 | 10-30 V | 11,5 W | 1800 | Ampio/largo / Flood beam | 12 | PMMA | Alluminio / Aluminium | Cavo 100 cm / Cable 100 cm | Vite M8 / M8 screw | IP67 | senza interruttore / no switch |
| 68048 | 1 | 10-30 V | 10,5 W | 1800 | Ampio/largo / Flood beam | 12 | PMMA | Alluminio / Aluminium | Cavo 100 cm / Cable 100 cm | Vite M8 / M8 screw | IP67 | con interruttore / with switch |
| 48049 | 2 | 10-30 V | 14,2 W | 2400 | Ampio/largo / Flood beam | 16 | PMMA | Alluminio / Aluminium | Cavo 100 cm / Cable 100 cm | Vite M8 / M8 screw | IP67 | senza interruttore / no switch |
| 68049 | 2 | 10-30 V | 13,2 W | 2400 | Ampio/largo / Flood beam | 16 | PMMA | Alluminio / Aluminium | Cavo 100 cm / Cable 100 cm | Vite M8 / M8 screw | IP67 | con interruttore / with switch |
| 48050 | 3 | 10-30 V | 26,3 W | 3800 | Ampio/largo / Flood beam | 30 | PMMA | Alluminio / Aluminium | Cavo 100 cm / Cable 100 cm | Vite M10 / M10 screw | IP67 | senza interruttore / no switch |
| 68050 | 3 | 10-30 V | 26,3 W | 3800 | Ampio/largo / Flood beam | 30 | PMMA | Alluminio / Aluminium | Cavo 100 cm / Cable 100 cm | Vite M10 / M10 screw | IP67 | con interruttore / with switch |

FARI DA LAVORO LED QUADRATI

SQUARE LED WORK LIGHTS
 PHARES DE TRAVAIL LED CARRÉS
 QUADRATISCHE LED-ARBEITSSCHEINWERFER
 FAROS DE TRABAJO LED CUADRADOS



CE, RoHS, CISPR 25 Classe 2

| Skü | Tensione nominale / Rated voltage | Potenza nominale / Rated power | Lumen | Flusso luminoso / Luminous flux | Numero led / Number of LEDs | Materiale lente / Lens material | Corpo faro / Light body | Collegamento elettrico / Electrical connection | Fissaggio / Fastening | Grado protezione ip / Degree of protection ip |
|----------------|-----------------------------------|--------------------------------|-------|---------------------------------|-----------------------------|---------------------------------|-------------------------|--|-----------------------|---|
| OF01105 | 10-30 V | 48 W | 3200 | Ampio/largo / Flood beam | 16 | PMMA | Alluminio / Aluminium | Cavo 40-60 cm / Cable 40-60 cm | Vite M8 / M8 screw | IP68 |
| 61105 | 10-36 V | 48 W | 3600 | Ampio/largo / Flood beam | 16 | PMMA | Alluminio / Aluminium | Cavo 40 cm / Cable 40 cm | Vite M8 / M8 screw | IP67 |

FARO LAVORO LED QUADRATO 10-30V, 50W, 4200LM

LED WORK LIGHT SQUARE 10-30V, 50W, 4200LM
 PROJECTEUR DE TRAVAIL LED CARRÉ 10-30V, 50W, 4200LM
 LED-ARBEITSLEUCHTE QUADRAT 10-30V, 50W, 4200LM
 FARO DE TRABAJO LED CUADRADO 10-30V, 50W, 4200LM



CE, RoHS, CISPR 25 Classe 3

| Skü | Tensione nominale / Rated voltage | Potenza nominale / Rated power | Lumen | Flusso luminoso / Luminous flux | Numero led / Number of LEDs | Materiale lente / Lens material | Corpo fero / Light body | Collegamento elettrico / Electrical connection | Fissaggio / Fastening | Grado protezione ip / Degree of protection ip |
|--------------|-----------------------------------|--------------------------------|---------|---------------------------------|-----------------------------|---------------------------------|-------------------------|---|-----------------------|---|
| 62105 | 10-30 V | 50 W | 4200 LM | Ampio/largo / Flood beam | 5 | PMMA | Alluminio / Aluminium | Connettore Deutsch 2 vie / 2-pole Deutsch connector | Vite M8 / M8 screw | IP68 |

FARO DA LAVORO A LED QUADRATO 12-24V 1000LM

SQUARE LED WORK LIGHT 12-24V 1000LM
 PHARE DE TRAVAIL LED CARRÉ 12-24V 1000LM
 QUADRATISCHER LED-ARBEITSSCHEINWERFER 12-24V 1000LM
 LUZ DE TRABAJO LED CUADRADO 12-24V 1000LM



CE, RoHS, CISPR 25 Classe 2

| Skü | Tensione nominale / Rated voltage | Potenza nominale / Rated power | Lumen | Flusso luminoso / Luminous flux | Numero led / Number of LEDs | Materiale lente / Lens material | Corpo fero / Light body | Collegamento elettrico / Electrical connection | Fissaggio / Fastening | Grado protezione ip / Degree of protection ip |
|----------------|-----------------------------------|--------------------------------|---------|---------------------------------|-----------------------------|---------------------------------|-------------------------|--|-----------------------|---|
| 0F01108 | 12-24 V | 9 W | 1000 LM | Ampio/largo / Flood beam | 9 | PC | Alluminio / Aluminium | Cavo 30 cm / Cable 30 cm | Vite M10 / M10 screw | IP67 |

FARO LAVORO LED OVALE 10-30V 4620 LM

OVAL LED WORK LIGHT 10-30V 4620 LM
 PHARE DE TRAVAIL LED OVALE 10-30V 4620 LM
 OVALER LED-ARBEITSSCHEINWERFER 10-30V 4620 LM
 FARO DE TRABAJO LED OVALADO 10-30V 4620 LM



CE, RoHS, REACH, CISPR 25 Classe 4

| Skü | Tensione nominale / Rated voltage | Potenza nominale / Rated power | Lumen | Flusso luminoso / Luminous flux | Numero led / Number of LEDs | Materiale lente / Lens material | Corpo fero / Light body | Collegamento elettrico / Electrical connection | Fissaggio / Fastening | Grado protezione ip / Degree of protection ip |
|--------------|-----------------------------------|--------------------------------|---------|---------------------------------|-----------------------------|---------------------------------|-------------------------|--|-----------------------|---|
| 65262 | 10-30 V / 10-30 V DC | 60 W | 4620 LM | Ampio/largo / Flood beam | 60 | PC / polycarbonate | alluminio / aluminum | cavo 50 cm / cable 50 cm | Vite M10 / M10 screw | IP68 |

FARO LAVORO LED OVALE 10-30V 9600 LM

OVAL LED WORK LIGHT 10-30V 9600 LM
 PHARE DE TRAVAIL LED OVALE 10-30V 9600 LM
 OVALER LED-ARBEITSSCHEINWERFER 10-30V 9600 LM
 FARO DE TRABAJO LED OVALADO 10-30V 9600 LM



CE, RoHS, REACH, CISPR 25 Classe 4

| Skü | Tensione nominale / Rated voltage | Potenza no- minale / Rated power | Lumen | Flusso lumino- so / Luminous flux | Numero led / Number of LEDs | Materiale lente / Lens material | Corpo fero / Light body | Collegamento elettrico / Electrical connection | Fissaggio / Fastening | Grado protezione ip / Degree of protection ip |
|--------------|--------------------------------------|--|---------|---|--------------------------------|---------------------------------------|----------------------------|--|--------------------------|---|
| 65263 | 10-30 V / 10-30 V DC | 120 W | 9600 LM | Ampio/largo / Flood beam | 120 | PC | alluminio / aluminum | cavo 50 cm / cable 50 cm | Vite M10 / M10 screw | IP68 |

FARO LAVORO LED OVALE 10-30V 12000 LM

OVAL LED WORK LIGHT 10-30V 12000 LM
 PHARE DE TRAVAIL LED OVALE 10-30V 12000 LM
 OVALER LED-ARBEITSSCHEINWERFER 10-30V 12000 LM
 FARO DE TRABAJO LED OVALADO 10-30V 12000 LM



CE, RoHS, REACH, CISPR 25 Classe 4

| Skü | Tensione nominale / Rated voltage | Potenza no- minale / Rated power | Lumen | Flusso lumino- so / Luminous flux | Numero led / Number of LEDs | Materiale lente / Lens material | Corpo fero / Light body | Collegamento elettrico / Electrical connection | Fissaggio / Fastening | Grado protezione ip / Degree of protection ip |
|--------------|--------------------------------------|--|----------|---|--------------------------------|---------------------------------------|----------------------------|--|--------------------------|---|
| 65264 | 10-30 V / 10-30 V DC | 150 W | 12000 LM | Ampio/largo / Flood beam | 150 | PC | alluminio / aluminum | cavo 50 cm / cable 50 cm | Vite M10 / M10 screw | IP68 |

FARO LAVORO LED OVALE 10-30V 12800 LM

OVAL LED WORK LIGHT 10-30V 12800 LM
 PHARE DE TRAVAIL LED OVALE 10-30V 12800 LM
 OVALER LED-ARBEITSSCHEINWERFER 10-30V 12800 LM
 FARO DE TRABAJO LED OVALADO 10-30V 12800 LM



CE, RoHS, REACH, CISPR 25 Classe 4

| Skü | Tensione nominale / Rated voltage | Potenza no- minale / Rated power | Lumen | Flusso lumino- so / Luminous flux | Numero led / Number of LEDs | Materiale lente / Lens material | Corpo fero / Light body | Collegamento elettrico / Electrical connection | Fissaggio / Fastening | Grado protezione ip / Degree of protection ip |
|--------------|--------------------------------------|--|----------|---|--------------------------------|---------------------------------------|----------------------------|--|--------------------------|---|
| 65265 | 10-30 V / 10-30 V DC | 160 W | 12800 LM | Ampio/largo / Flood beam | 160 | PC | alluminio / aluminum | cavo 50 cm / cable 50 cm | Vite M10 / M10 screw | IP68 |

FARO LAVORO A LED OVALE 10-30V, 8840 LM

OVAL LED WORK LIGHT, 10-30V, 8840 LM
 PROJECTEUR DE TRAVAIL LED OVALE, 10-30V, 8840 LM
 OVALER LED-ARBEITSSCHEINWERFER, 10-30V, 8840 LM
 FARO DE TRABAJO LED OVALADO, 10-30V, 8840 LM



| Skü | Tensione nominale / Rated voltage | Potenza nominale / Rated power | Lumen | Flusso luminoso / Luminous flux | Numero led / Number of LEDs | Materiale lente / Lens material | Corpo fero / Light body | Collegamento elettrico / Electrical connection | Fissaggio / Fastening | Grado protezione ip / Degree of protection ip |
|-------|-----------------------------------|--------------------------------|--------|------------------------------------|-----------------------------|---------------------------------|-------------------------|--|-----------------------|---|
| 65090 | 10-30 V DC | 40W-68W | 8840LM | Ampio/largo (90°) / Flood beam 90° | 4 | PC | alluminio / aluminum | connettore 9006 / 9006 connector | M10 | IP69K |

FARI LAVORO LED OVALI 1800 LM

OVAL LED WORK LIGHTS 1800LM
 PHARES DE TRAVAIL LED OVALES 1800LM
 OVALE LED-ARBEITSSCHEINWERFER 1800 LM
 FAROS DE TRABAJO LED OVALADOS 1800LM



CE, RoHS, CISPR 25 Classe 2

| Skü | Tensione nominale / Rated voltage | Potenza nominale / Rated power | Lumen | Flusso luminoso / Luminous flux | Numero led / Number of LEDs | Materiale lente / Lens material | Corpo fero / Light body | Collegamento elettrico / Electrical connection | Fissaggio / Fastening | Grado protezione ip / Degree of protection ip |
|---------|-----------------------------------|--------------------------------|---------|---------------------------------|-----------------------------|---------------------------------|-------------------------|--|-----------------------|---|
| 0F01115 | 12-28 V | 24 W | 1800 LM | Lungo/profondo / Spot beam | 8 | PC | Alluminio / Aluminium | Cavo 40 cm / Cable 40 cm | Vite M10 / M10 screw | IP67 |
| 61115 | 10-36 V | 24 W | 1800 LM | Lungo/profondo / Spot beam | 8 | PMMA | Alluminio / Aluminium | Cavo 40 cm / Cable 40 cm | Vite M8 / M8 screw | IP67 |

FARO LAVORO LED OVALE 10-36V DC, 39W, 3120LM

LED WORK LIGHT OVAL 10-36V DC, 39W, 3120LM
 PROJECTEUR DE TRAVAIL LED OVALE 10-36V DC, 39W, 3120LM
 LED-ARBEITSLUCHTE OVAL 10-36V DC, 39W, 3120LM
 FARO DE TRABAJO LED OVALADO 10-36V DC, 39W, 3120LM



CE, RoHS, UKCA, CISPR 25 Classe 2

| Skü | Tensione nominale / Rated voltage | Potenza nominale / Rated power | Lumen | Flusso luminoso / Luminous flux | Numero led / Number of LEDs | Materiale lente / Lens material | Corpo fero / Light body | Collegamento elettrico / Electrical connection | Fissaggio / Fastening | Grado protezione ip / Degree of protection ip |
|-------|-----------------------------------|--------------------------------|---------|---------------------------------|-----------------------------|---------------------------------|-------------------------|--|-----------------------|---|
| 68052 | 10-36 V | 39 W | 3120 LM | Ampio/largo / Flood beam | 13 | PMMA | Alluminio / Aluminium | Cavo 38 cm / Cable 38 cm | Vite M8 / M8 screw | IP67 |

FARO LAVORO LED OVALE 10-36V, 42W, 3150LM

LED WORK LIGHT OVAL 10-36V, 42W, 3150LM
 PROJECTEUR DE TRAVAIL LED OVALE 10-36V, 42W, 3150LM
 LED-ARBEITSLEUCHTE OVAL 10-36V, 42W, 3150LM
 FARO DE TRABAJO LED OVALADO 10-36V, 42W, 3150LM



CE, RoHS, UKCA, CISPR 25 Classe 3

| Skü | Tensione nominale / Rated voltage | Potenza nominale / Rated power | Lumen | Flusso luminoso / Luminous flux | Numero led / Number of LEDs | Materiale lente / Lens material | Corpo fero / Light body | Collegamento elettrico / Electrical connection | Fissaggio / Fastening | Grado protezione ip / Degree of protection ip |
|--------------|-----------------------------------|--------------------------------|---------|------------------------------------|--|---------------------------------|-------------------------|--|-----------------------|---|
| 61080 | 10-36 V | 42W | 3150 LM | Ampio e lungo (COMBO) / Flood beam | 8 bianchi, 6 arancioni / white 8 LED's, orange 6 LED's | PMMA | Alluminio / Aluminium | Cavo 35 cm / Cable 35 cm | Vite M8 / M8 screw | IP67 |

FARI DA LAVORO LED OVALE

OVAL LED WORK LIGHTS
 PHARES DE TRAVAIL LED OVALES
 OVALE LED-ARBEITSSCHEINWERFER
 FAROS DE TRABAJO LED OVALADOS

1
2

CE, RoHS, CISPR 25 Classe 2

| Skü | Pos. | Tensione nominale / Rated voltage | Potenza nominale / Rated power | Lumen | Flusso luminoso / Luminous flux | Numero led / Number of LEDs | Materiale lente / Lens material | Corpo fero / Light body | Collegamento elettrico / Electrical connection | Fissaggio / Fastening | Grado protezione ip / Degree of protection ip |
|----------------|------|-----------------------------------|--------------------------------|---------|---------------------------------|-----------------------------|---------------------------------|-------------------------|--|-----------------------|---|
| 0F01088 | 2 | 10-60 V | 10 W | 850 LM | Lungo/profondo / Spot beam | 2 bianchi / white 2 LED's | PMMA | Alluminio / Aluminium | Cavo 32 cm / Cable 32 cm | Vite M8 / M8 screw | |
| 61088 | 2 | 10-36 V | 20 W | 850 LM | Lungo/profondo / Spot beam | 2 bianchi / white 2 LED's | PMMA | Alluminio / Aluminium | Cavo 40 cm / Cable 40 cm | Vite M8 / M8 screw | IP67 |
| 63107 | 1 | 10-60 V | 10 W | 1000 LM | Lungo/profondo / Spot beam | 2 blu / blue 2 LED's | PMMA | Alluminio / Aluminium | Cavo 32 cm / Cable 32 cm | Vite M8 / M8 screw | IP67 |

FARO DA LAVORO A LED OVALE 12-24V 1500LM

OVAL LED WORK LIGHT 12-24V 1500LM
 PHARE DE TRAVAIL LED OVALE 12-24V 1500LM
 OVALER LED-ARBEITSSCHEINWERFER 12-24V 1500LM
 LUZ DE TRABAJO LED OVALADO 12-24V 1500LM



| Skü | Tensione nominale / Rated voltage | Potenza nominale / Rated power | Lumen | Flusso luminoso / Luminous flux | Numero led / Number of LEDs | Materiale lente / Lens material | Corpo fero / Light body | Collegamento elettrico / Electrical connection | Fissaggio / Fastening | Grado protezione ip / Degree of protection ip |
|----------------|-----------------------------------|--------------------------------|---------|---------------------------------|-----------------------------|---------------------------------|-------------------------|---|-----------------------|---|
| 0F01131 | 12-24 V | 18 W | 1500 LM | Ampio/largo / Flood beam | 6 | PMMA | PMMA | Connettore Deutsch 2 vie / 2-pole Deutsch connector | Vite M8 / M8 screw | IP 68 |

FARO LAVORO TRIANGOLARE LED 10-30V, 9W, 1200LM

LED WORK LIGHT TRIANGULAR 10-30V, 9W, 1200LM
 PROJECTEUR DE TRAVAIL LED TRIANGULAIRE 10-30V, 9W, 1200LM
 LED-ARBEITSLEUCHTE DREIECK 10-30V, 9W, 1200LM
 FARO DE TRABAJO LED TRIANGULAR 10-30V, 9W, 1200LM



CE, RoHS, UKCA, CISPR 25 Classe 2

| Skü | Tensione nominale / Rated voltage | Potenza nominale / Rated power | Lumen | Flusso luminoso / Luminous flux | Numero led / Number of LEDs | Materiale lente / Lens material | Corpo faro / Light body | Collegamento elettrico / Electrical connection | Fissaggio / Fastening | Grado protezione ip / Degree of protection ip |
|--------------|-----------------------------------|--------------------------------|---------|---------------------------------|-----------------------------|---------------------------------|-------------------------|--|-----------------------|---|
| 68038 | 10-30 V | 9 W | 1200 LM | Ampio/largo / Flood beam | 3 | PC | Alluminio / Aluminum | Cavo 40 cm / Cable 40 cm | Vite M8 / M8 screw | IP67 |

FARO LAVORO LED QUADRATO CON LENTE RISCALDATA 9-30V, 40W, 4590 LM

LED WORK LIGHT SQUARE WITH HEATED LENS 9-30V, 40W, 4590LM
 PROJECTEUR DE TRAVAIL LED CARRÉ AVEC LENTILLE CHAUFFÉE 9-30V, 40W, 4590LM
 LED-ARBEITSLEUCHTE QUADRAT MIT BEHEIZTEM LINSENEINSATZ 9-30V, 40W, 4590LM
 FARO DE TRABAJO LED CUADRADO CON LENTE CALEFACTADA 9-30V, 40W, 4590LM



CE, RoHS, CISPR 25 Classe 5

| Skü | Tensione nominale / Rated voltage | Potenza nominale / Rated power | Lumen | Flusso luminoso / Luminous flux | Numero led / Number of LEDs | Materiale lente / Lens material | Corpo faro / Light body | Collegamento elettrico / Electrical connection | Fissaggio / Fastening | Grado protezione ip / Degree of protection ip | Note / Notes |
|--------------|-----------------------------------|--------------------------------|---------|---------------------------------|-----------------------------|---------------------------------|-------------------------|---|-----------------------|---|---|
| 64477 | 9-30 V | 40 W | 4590 LM | Ampio/largo / Flood beam | 36 | Vetro temprato / Tempered glass | Alluminio / Aluminium | Connettore Deutsch 2 vie / 2-pole Deutsch connector | vite M10 / M10 screw | IP69K | Sistema automatico anti-neve e anti-ghiaccio / Automatic snow and ice protection system |

FARO DA LAVORO LED QUADRATO 12-24V, 13,5W, 1650LM, PER RETROMARCIA

LED WORK LIGHT SQUARE 12-24V, 13.5W, 1650LM, FOR REVERSING
 PROJECTEUR DE TRAVAIL LED CARRÉ 12-24V, 13,5W, 1650LM, POUR MARCHÉ ARRIÈRE
 LED-ARBEITSLEUCHTE QUADRAT 12-24V, 13,5W, 1650LM, FÜR RÜCKWÄRTSFAHRT
 FARO DE TRABAJO LED CUADRADO 12-24V, 13,5W, 1650LM, PARA MARCHA ATRÁS



ECE, CE, RoHS, CISPR 25 Classe 3

| Skü | Tensione nominale / Rated voltage | Potenza nominale / Rated power | Lumen | Flusso luminoso / Luminous flux | Numero led / Number of LEDs | Materiale lente / Lens material | Corpo faro / Light body | Collegamento elettrico / Electrical connection | Fissaggio / Fastening | Grado protezione ip / Degree of protection ip | Funzioni / Functions |
|--------------|-----------------------------------|--------------------------------|---------|---------------------------------|-----------------------------|---------------------------------|-------------------------|--|-----------------------|---|---|
| 64476 | 12-24 V | 13,5 W | 1650 LM | Ampio/largo / Flood beam | 9 | PMMA | Alluminio / Aluminum | Cavo 50 cm / Cable 50 cm | Vite M10 / M10 screw | IP67, IP69K | omologato per retromarcia / type-approved for reverse |

LUCE DA LAVORO QUADRATA LED LUCE BLU, ILLUMINAZIONE DISERBO

SQUARE LED WORK LIGHT WITH BLUE LIGHT, LIGHTING FOR WEEDING
 LAMPE DE TRAVAIL LED CARRÉE AVEC LUMIÈRE BLEUE, ÉCLAIRAGE POUR LE DÉSHÉRBAGE
 QUADRATISCHE LED-ARBEITSLEUCHTE MIT BLAUEM LICHT, BELEUCHTUNG ZUM JÄTEN
 LUZ DE TRABAJO LED CUADRADA CON LUZ AZUL, ILUMINACIÓN PARA DESHERBE



CE, RoHS, CISPR 25 Classe 2

| Skü | Tensione nominale / Rated voltage | Potenza nominale / Rated power | Flusso luminoso / Luminous flux | Numero led / Number of LEDs | Materiale lente / Lens material | Corpo fero / Light body | Fissaggio / Fastening | Grado protezione ip / Degree of protection ip |
|--------------|-----------------------------------|--------------------------------|---------------------------------|-----------------------------|---------------------------------|-------------------------|-----------------------|---|
| 64023 | 12-30V | 24 W | Ampio/largo / Flood beam | 4 blu / 4 blue | PC | Alluminio / Aluminum | M8 | IP69K |

LUCE DA LAVORO QUADRATA LED LUCE BLU, 10-30V 180LM ILLUMINAZIONE DISERBO

SQUARE LED WORK LIGHT BLUE LIGHT, 10-30V 180LM, WEEDING ILLUMINATION
 PHARE DE TRAVAIL CARRÉ LED LUMIÈRE BLEUE, 10-30V 180LM, ÉCLAIRAGE DE DÉSHÉRBAGE
 QUADRATISCHER LED-ARBEITSSCHEINWERFER MIT BLAUEM LICHT, 10-30V 180LM, UNKRAUTBEKÄMPFUNGSBELEUCHTUNG
 LUZ DE TRABAJO CUADRADA LED LUZ AZUL, 10-30V 180LM, ILUMINACIÓN PARA DESHERBE



CE, RoHS, CISPR 25 Classe 2

| Skü | Tensione nominale / Rated voltage | Potenza nominale / Rated power | Lumen | Flusso luminoso / Luminous flux | Numero led / Number of LEDs | Materiale lente / Lens material | Corpo fero / Light body | Collegamento elettrico / Electrical connection | Fissaggio / Fastening | Grado protezione ip / Degree of protection ip |
|--------------|-----------------------------------|--------------------------------|--------|---------------------------------|-----------------------------|---------------------------------|-------------------------|---|-----------------------|---|
| 63115 | 10-30V | 16 W | 180 LM | Ampio/largo / Flood beam | 4 blu / blue 4 LED's | PMMA | Alluminio / Aluminium | Connettore Deutsch 2 vie / 2-pole Deutsch connector | Vite M10 / M10 screw | IP6K9K |

FARI LAVORO LED OVALI, LUCE BLU E ROSSA 10-100V, 10W, 500LM, ILLUMINAZIONE PAVIMENTO

LED WORK LIGHTS OVAL, BLUE AND RED LIGHT 10-100V, 10W, 500LM, FLOOR SAFETY LIGHTING

PROJECTEURS DE TRAVAIL LED OVALES, BLEUE ET ROUGE 10-100V, 10W, 500LM, ÉCLAIRAGE DE SÉCURITÉ

LED-ARBEITSLEUCHTEN OVAL, BLAUE UND ROTE BELEUCHTUNG 10-100V, 10W, 500LM, SICHERHEITSBODENBELEUCHTUNG

FAROS DE TRABAJO LED OVALADOS, LUZ AZUL Y ROJA 10-100V, 10W, 500LM, ILUMINACIÓN DE SEGURIDAD EN EL S



1



2



CE, RoHS, REACH, CISPR 25 Classe 2

| Skü | Pos. | Tensione nominale / Rated voltage | Potenza nominale / Rated power | Lumen | Flusso luminoso / Luminous flux | Numero led / Number of LEDs | Materiale lente / Lens material | Corpo fero / Light body | Collegamento elettrico / Electrical connection | Fissaggio / Fastening | Grado protezione ip / Degree of protection ip |
|--------|------|-----------------------------------|--------------------------------|--------|---------------------------------|-----------------------------|---------------------------------|-------------------------|---|-----------------------|---|
| 57380T | 1 | 10-110 V | 10 W | 500 LM | Luce a pavimento / Zone light | 2 Blu / 2 blue | PMMA | Alluminio / Aluminium | Cavo 40 cm con connettore 2 poli / 40 cm cable with 2-pin connector | Vite M10 / M10 screw | IP67 |
| 57381 | 2 | 10-110 V | 10 W | 500 LM | Luce a pavimento / Zone light | 2 Rossi / Red 2 LED's | PMMA | Alluminio / Aluminium | Cavo 40 cm / Cable 40 cm | Vite M10 / M10 screw | IP67 |

BARRE LUCI DA LAVORO LED OVALI, LUCE BLU E ROSSA 10-80V, 18W, 500LM, ILLUMINAZIONE PAVIMENTO

OVAL LED WORK LIGHT BARS, BLUE AND RED LIGHT 10-80V, 18W, 500LM, FLOOR SAFETY LIGHTING

BARRES DE LUMIÈRES DE TRAVAIL LED OVALES, BLEUE ET ROUGE 10-80V, 18W, 500LM, ÉCLAIRAGE DE SÉ

OVALE LED-ARBEITSLICHTLEISTEN, BLAUE UND ROTE BELEUCHTUNG 10-100V, 10W, 500LM, SICHERHEITSBODENBELEU

BARRAS DE LUCES DE TRABAJO LED OVALADAS, LUZ AZUL Y ROJA 10-80V, 18W, 500LM, ILUMINACIÓN DE SEGURIDA



1



2



CE, RoHS, CISPR 25 Classe 2

| Skü | Pos. | Tensione nominale / Rated voltage | Potenza nominale / Rated power | Lumen | Flusso luminoso / Luminous flux | Numero led / Number of LEDs | Materiale lente / Lens material | Corpo fero / Light body | Collegamento elettrico / Electrical connection | Fissaggio / Fastening | Grado protezione ip / Degree of protection ip |
|-------|------|-----------------------------------|--------------------------------|--------|---------------------------------|-----------------------------|---------------------------------|-------------------------|--|-----------------------|---|
| 57390 | 1 | 10-80 V | 18 W | 500 LM | Luce a pavimento / Zone light | 6 Blu / Blue 6 LED's | PMMA | Alluminio / Aluminium | Cavo 40 cm / Cable 40 cm | Viti M8 / M8 screws | IP67 |
| 57391 | 2 | 10-80 V | 18 W | 500 LM | Luce a pavimento / Zone light | 6 Rossi / Red 6 LED's | PMMA | Alluminio / Aluminium | Cavo 40 cm / Cable 40 cm | Viti M8 / M8 screws | IP67 |

BARRE A LED 9-30V, LUCE DIURNA, DA LAVORO E LAMPEGGIANTE

LED LIGHT BAR 9-30V, DRL, WORK LIGHT AND FLASHING LIGHT
 BARRE LED 9-30V, DRL, LUMIÈRE DE TRAVAIL ET CLIGNOTANTE
 LED-LICHTLEISTE 9-30V, TFL, ARBEITSLICHT UND BLINKLICHT
 BARRE LED 9-30V, DRL, LUMIÈRE DE TRAVAIL ET CLIGNOTANTE



| Skü | Pos. | Tensione nominale / Rated voltage | Potenza nominale / Rated power | Lumen | Flusso luminoso / Luminous flux | Numero led / Number of LEDs | Funzioni / Functions | Materiali / Material | Interasse fori / Hole spacing |
|-------|------|-----------------------------------|---|-------|---|------------------------------|--|-------------------------------|-------------------------------|
| 65240 | 1 | 9-30 V DC | 9W (luce lavoro), 18W (luce lampeggiante) / 9W (work light), 18W (strobe light) | 600 | COMBO (ampio e lungo) / Combo (flood and spot beam) | 9 LED Osram / 9 Osram LEDs | Luce diurna (bianco+ambra), Luce lampeggiante su due lati (R65), Luce da lavoro (bianca). / DRL (white + amber), two-side strobe light (R65), work light (white) | alluminio, PC / aluminium, PC | 273 mm |
| 65241 | 2 | 9-30 V DC | 36W (luce lavoro), 18W (luce lampeggiante) / 36W (work light), 18W (strobe light) | 1800 | COMBO (ampio e lungo) / Combo (flood and spot beam) | 18 LED Osram / 18 Osram LEDs | Luce diurna (bianco+ambra), Luce lampeggiante su due lati (R65), Luce da lavoro (bianca). / DRL (white + amber), two-side strobe light (R65), work light (white) | alluminio, PC / aluminium, PC | 460 mm |
| 65242 | 3 | 9-30 V DC | 54W (luce lavoro), 18W (luce lampeggiante) / 54W (work light), 18W (strobe light) | 3200 | COMBO (ampio e lungo) / Combo (flood and spot beam) | 24 LED Osram / 24 Osram LEDs | Luce diurna (bianco+ambra), Luce lampeggiante su due lati (R65), Luce da lavoro (bianca). / DRL (white + amber), two-side strobe light (R65), work light (white) | alluminio, PC / aluminium, PC | 618 mm |

BARRE LUCI DA LAVORO LED 10-30V

LED WORK LIGHT BARS 10-30V
 BARRES DE LUMIÈRES DE TRAVAIL LED 10-30V
 LED ARBEITSLICHTLEISTEN 10-30V
 BARRAS DE LUCES DE TRABAJO LED 10-30V



CE, RoHS, UKCA, CISPR 25 Classe 1

| Skü | Pos. | Tensione nominale / Rated voltage | Potenza nominale / Rated power | Lumen | Flusso luminoso / Luminous flux | Numero led / Number of LEDs | Materiali lente / Lens material | Corpo fero / Light body | Collegamento elettrico / Electrical connection | Fissaggio / Fastening | Grado protezione ip / Degree of protection ip |
|-------|------|-----------------------------------|--------------------------------|---------|---------------------------------|-----------------------------|---------------------------------|-------------------------|--|-----------------------|---|
| 99394 | 1 | 10-30 V | 18 W | 1620 LM | Ampio/largo (90°) / Flood beam | 6 | PMMA | Alluminio / Aluminium | Cavo 25 cm / Cable 25 cm | Vite M8 / M8 screw | IP68 |
| 99395 | 2 | 10-30 V | 36 W | 3240 LM | Ampio/largo (90°) / Flood beam | 12 | PMMA | Alluminio / Aluminium | Cavo 25 cm / Cable 25 cm | Vite M8 / M8 screw | IP68 |

BARRA LUCE DA LAVORO LED 12-28V 2700LM

LED WORK LIGHT BAR 12-28V 2700LM

BARRE LUMINEUSE LED 12-28V 2700LM

LICHTLEISTE LED 12-28V 2700LM

BARRA DE LUCES DE TRABAJO LED 12-28V 2700LM



CE, RoHS, CISPR 25 Classe 3

| Skü | Tensione nominale / Rated voltage | Potenza nominale / Rated power | Lumen | Flusso luminoso / Luminous flux | Numero led / Number of LEDs | Materiale lente / Lens material | Corpo fero / Light body | Collegamento elettrico / Electrical connection | Fissaggio / Fastening | Grado protezione ip / Degree of protection ip |
|-------|-----------------------------------|--------------------------------|---------|---------------------------------|-----------------------------|---------------------------------|-------------------------|--|-----------------------|---|
| 84027 | 12-28 V | 36 W | 2700 LM | Lungo/profondo / Spot beam | 12 | PMMA | Alluminio / Aluminium | Cavo 40 cm / Cable 40 cm | Vite M10 / M10 screw | IP67 |

BARRE LUCI DA LAVORO LED 10-30V

LED WORK LIGHT BARS 10-30V

BARRES DE LUMIÈRES DE TRAVAIL LED 10-30V

LED ARBEITSLICHTLEISTEN 10-30V

BARRAS DE LUCES DE TRABAJO LED 10-30V



1



2



3

CE, RoHS, UKCA, CISPR 25 Classe 1

| Skü | Pos. | Tensione nominale / Rated voltage | Potenza nominale / Rated power | Lumen | Flusso luminoso / Luminous flux | Numero led / Number of LEDs | Materiale lente / Lens material | Corpo fero / Light body | Collegamento elettrico / Electrical connection | Fissaggio / Fastening | Grado protezione ip / Degree of protection ip | Interasse fori / Hole spacing |
|-------|------|-----------------------------------|--------------------------------|-------|--|-----------------------------|---------------------------------|-------------------------|--|-----------------------|---|-------------------------------|
| 99396 | 1 | 10-48 V | 36 W | 3240 | Ampio/largo (90°) / Flood beam | 12 | PMMA | Alluminio / Aluminium | Cavo 25 cm / Cable 25 cm | 2 asole M6 / M6 slots | IP68 | 222 |
| 99397 | 2 | 10-48 V | 72 W | 6480 | Ampio/largo (90°) / Flood beam | 24 | PMMA | Alluminio / Aluminium | Cavo 25 cm / Cable 25 cm | 2 asole M6 / M6 slots | IP68 | 375 |
| 99398 | 3 | 10-48 V | 120 W | 10800 | COMBO (ampio e lungo) / Combo (Flood&Spot) | 40 | PMMA | Alluminio / Aluminium | Cavo 25 cm / Cable 25 cm | 2 asole M6 / M6 slots | IP68 | 579 |
| 99399 | 3 | 10-48 V | 180 W | 16200 | COMBO (ampio e lungo) / Combo (Flood&Spot) | 60 | PMMA | Alluminio / Aluminium | Cavo 25 cm / Cable 25 cm | 2 asole M6 / M6 slots | IP68 | 834 |
| 99400 | 3 | 10-48 V | 240 W | 21600 | COMBO (ampio e lungo) / Combo (Flood&Spot) | 80 | PMMA | Alluminio / Aluminium | Cavo 25 cm / Cable 25 cm | 2 asole M6 / M6 slots | IP68 | 1069 |
| 99401 | 3 | 10-48 V | 288 W | 25920 | COMBO (ampio e lungo) / Combo (Flood&Spot) | 96 | PMMA | Alluminio / Aluminium | Cavo 25 cm / Cable 25 cm | 2 asole M6 / M6 slots | IP68 | 1293 |
| 99402 | 3 | 10-48 V | 300 W | 27000 | COMBO (ampio e lungo) / Combo (Flood&Spot) | 100 | PMMA | Alluminio / Aluminium | Cavo 25 cm / Cable 25 cm | 2 asole M6 / M6 slots | IP68 | 1364 |

BARRA LUCE DA LAVORO LED 12-28V 4050LM

LED WORK LIGHT BAR 12-28V 4050LM

BARRE LUMINEUSE LED 12-28V 4050LM

LICHTLEISTE LED 12-28V 4050LM

BARRA DE LUCES DE TRABAJO LED 12-28V 4050LM



CE, RoHS, CISPR 25 Classe 3

| Skü | Tensione nominale / Rated voltage | Potenza nominale / Rated power | Lumen | Flusso luminoso / Luminous flux | Numero led / Number of LEDs | Materiale lente / Lens material | Corpo faro / Light body | Collegamento elettrico / Electrical connection | Fissaggio / Fastening | Grado protezione ip / Degree of protection ip |
|-------|-----------------------------------|--------------------------------|---------|---------------------------------|-----------------------------|---------------------------------|-------------------------|--|-----------------------|---|
| 84377 | 12-28 V | 54 W | 4050 LM | Lungo/profondo / Spot beam | 18 | PMMA | Alluminio / Aluminium | Cavo 40 cm / Cable 40 cm | Viti M10 / M10 screws | IP67 |

FARO DA LAVORO ALOGENO RETTANGOLARE

RECTANGULAR HALOGEN WORK LIGHT

PHARE DE TRAVAIL HALOGÈNE RECTANGULAIRE

ALOGENER ARBEITSSCHEINWERFER RECHTECKIG

LUZ DE TRABAJO HALÓGENO RECTANGULAR



1



2

| Skü | Pos. | Tipo luce / Light type | Tensione nominale / Rated voltage | Materiale lente / Lens material | Corpo faro / Light body | Collegamento elettrico / Electrical connection | Note / Notes | Tipo lampadina / Bulb type | Prodotti compatibili / Compatible products | Funzioni / Functions |
|-------|------|------------------------|-----------------------------------|---------------------------------|-------------------------|---|---|----------------------------|--|--------------------------------|
| 19145 | 1 | Alogeno / Halogen | 12-24 V | Vetro / Glass | Plastica / Plastic | Cavo elettrico con terminale 6,3 / cable with 6.3 mm terminal | lampadina non inclusa / bulb not included | 12V 55W, 24V 70W | 00299,00446 | con interruttore / with switch |
| 19146 | 2 | Alogeno / Halogen | 12-24 V | PC | Plastica / Plastic | Cavo elettrico con terminale 6,3 / cable with 6.3 mm terminal | lampadina non inclusa / bulb not included | 12V 55W, 24V 70W | 00299,00446,00447 | |

FARO DA LAVORO ALOGENO RETTANGOLARE CON INTERRUTTORE

RECTANGULAR HALOGEN WORK LIGHT WITH SWITCH

PHARE DE TRAVAIL HALOGÈNE RECTANGULAIRE AVEC INTERRUPTEUR

ALOGENER ARBEITSSCHEINWERFER RECHTECKIG MIT SCHALTER

LUZ DE TRABAJO HALÓGENO RECTANGULAR CON INTERRUPTOR



| Skü | Tipo luce / Light type | Tensione nominale / Rated voltage | Materiale lente / Lens material | Corpo faro / Light body | Collegamento elettrico / Electrical connection | Note / Notes | Tipo lampadina / Bulb type |
|-------|------------------------|-----------------------------------|---------------------------------|-------------------------|---|---|----------------------------|
| 01149 | Alogeno / Halogen | 12-24 V | Vetro / Glass | ABS | Cavo con terminale da 6,3 mm / Cable with 6.3 mm terminal | Lampadina non inclusa / Bulb not included | 12V 55W, 24V 70W |

FARO LAVORO ALOGENO RETTANGOLARE HELLA

HELLA RECTANGULAR HALOGEN WORK LIGHT
 PHARE DE TRAVAIL HALOGÈNE RECTANGULAIRE HELLA
 RECHTECKIGER HALOGEN-ARBEITSSCHEINWERFER VON HELLA
 FARO DE TRABAJO HALÓGENO RECTANGULAR HELLA



| Skü | Tipo luce / Light type | Brand / Brand | Tensione nominale / Rated voltage | Materiale lente / Lens material | Corpo fero / Light body | Note / Notes | Tipo lampadina / Bulb type | Prodotti compatibili / Compatible products |
|---------|------------------------|---------------|-----------------------------------|---------------------------------|-------------------------|---|----------------------------|--|
| 0F01040 | Alogeno / Halogen | Hella | 12-24 V | vetro / glass | PC | lampadina non inclusa / bulb not included | H3 | 00299,00446 |

FARO DA LAVORO ALOGENO RETTANGOLARE

RECTANGULAR HALOGEN WORK LIGHT
 PHARE DE TRAVAIL HALOGÈNE RECTANGULAIRE
 ALOGENER ARBEITSSCHEINWERFER RECHTECKIG
 LUZ DE TRABAJO HALÓGENO RECTANGULAR



| Skü | Tipo luce / Light type | Tensione nominale / Rated voltage | Materiale lente / Lens material | Corpo fero / Light body | Collegamento elettrico / Electrical connection | Note / Notes | Prodotti compatibili / Compatible products |
|-------|------------------------|-----------------------------------|---------------------------------|-------------------------|--|--|--|
| 59775 | Alogeno / Halogen | 12-24 V | Vetro / Glass | PC | Cavo 150 mm / Cable 150 mm | lampadina 12 V inclusa / 12V bulb included | 00299,00446 |

FARO DA LAVORO ALOGENO RETTANGOLARE HELLA

HELLA RECTANGULAR HALOGEN WORK LIGHT
 PHARE DE TRAVAIL HELLA HALOGÈNE RECTANGULAIRE
 HELLA RECHTECKIGER ALOGENER ARBEITSSCHEINWERFER
 LUZ DE TRABAJO HELLA RECTANGULAR HALÓGENO



| Skü | Tipo luce / Light type | Brand / Brand | Tensione nominale / Rated voltage | Materiale lente / Lens material | Corpo fero / Light body | Collegamento elettrico / Electrical connection | Grado protezione ip / Degree of protection ip | Note / Notes | Tipo lampadina / Bulb type | Prodotti compatibili / Compatible products |
|-------|------------------------|---------------|-----------------------------------|---------------------------------|-------------------------|---|---|---|----------------------------|--|
| 35894 | Alogeno / Halogen | Hella | 12-24 V | vetro / glass | PC | Cavo elettrico con terminale 6,3 / cable with 6.3 mm terminal | IP5K4K | lampadina non inclusa / bulb not included | 12V 55W, 24V 70W | 00299,00446 |

FARO DA LAVORO ALOGENO ROTONDO CON MANIGLIA

ROUND HALOGEN WORK LIGHT WITH HANDLE
 PHARE DE TRAVAIL HALOGÈNE ROND AVEC POIGNÉE
 RUNDER ALOGENER ARBEITSSCHEINWERFER MIT GRIFF
 LUZ DE TRABAJO HALÓGENO REDONDO CON ASA



| Skü | Tipo luce / Light type | Tensione nominale / Rated voltage | Materiale lente / Lens material | Corpo fero / Light body | Fissaggio / Fastening | Dimensioni / Dimensions | Note / Notes | Tipo lampadina / Bulb type | Prodotti compatibili / Compatible products |
|----------------|------------------------|-----------------------------------|---------------------------------|-------------------------|-----------------------|-------------------------|---|----------------------------|--|
| 0F01073 | Alogeno / Halogen | 12-24 V | Vetro / Glass | ABS | Vite M8 / M8 screw | 168x100 | lampadina non inclusa / bulb not included | 12V 55W, 24V 70W | 00299,00446 |

FARO DA LAVORO ALOGENO RETTANGOLARE CON ATTACCO LATERALE

RECTANGULAR HALOGEN WORK LIGHT WITH SIDE MOUNT
 PHARE DE TRAVAIL HALOGÈNE RECTANGULAIRE AVEC FIXATION LATÉRALE
 RECHTECKIGER ALOGENER ARBEITSSCHEINWERFER MIT SEITLICHER BEFESTIGUNG
 LUZ DE TRABAJO HALÓGENO RECTANGULAR CON SOPORTE LATERAL



| Skü | Tipo luce / Light type | Tensione nominale / Rated voltage | Materiale lente / Lens material | Corpo fero / Light body | Lato / Side | Note / Notes | Tipo lampadina / Bulb type | Prodotti compatibili / Compatible products |
|----------------|------------------------|-----------------------------------|---------------------------------|-------------------------|--|---|----------------------------|--|
| 0F01081 | Alogeno / Halogen | 12-24 V | Vetro / Glass | ABS | Fissaggio laterale dx e sx / Side mounting, right and left | lampadina non inclusa / bulb not included | 12V 55W, 24V 70W | 00299,00446 |

FARO DA LAVORO ALOGENO QUADRATO

SQUARE HALOGEN WORK LIGHT
 PHARE DE TRAVAIL HALOGÈNE CARRÉ
 ALOGENER ARBEITSSCHEINWERFER QUADRATISCH
 LUZ DE TRABAJO HALÓGENO CUADRADO



| Skü | Tipo luce / Light type | Tensione nominale / Rated voltage | Materiale lente / Lens material | Corpo fero / Light body | Fissaggio / Fastening | Dimensioni / Dimensions | Grado protezione ip / Degree of protection ip | Note / Notes | Tipo lampadina / Bulb type | Prodotti compatibili / Compatible products |
|--------------|------------------------|-----------------------------------|---------------------------------|-------------------------|-----------------------|-------------------------|---|---|----------------------------|--|
| 03943 | Alogeno / Halogen | 12-24V | Vetro / Glass | ABS | Vite M10 / M10 screw | 124x124x84 | IP55 | lampadina non inclusa / bulb not included | 12V 55W, 24V 70W | 00299,00446 |

FARO DA LAVORO ALOGENO QUADRATO

SQUARE HALOGEN WORK LIGHT
 PHARE DE TRAVAIL HALOGÈNE CARRÉ
 ALOGENER ARBEITSSCHEINWERFER QUADRATISCH
 LUZ DE TRABAJO HALÓGENO CUADRADO



| Skü | Tipo luce / Light type | Tensione nominale / Rated voltage | Materiale lente / Lens material | Corpo fero / Light body | Collegamento elettrico / Electrical connection | Note / Notes | Tipo lampadina / Bulb type | Prodotti compatibili / Compatible products |
|-------|------------------------|-----------------------------------|---------------------------------|-------------------------|--|--|----------------------------|--|
| 17685 | Alogeno / Halogen | 12-24 V | Vetro / Glass | PC | Connettore AMP / AMP connector | lampadine non inclusa / bulbs not included | 12V 55W, 24V 70W | 00299,00446 |

FARO DA LAVORO ROTONDO ALOGENO DIAMETRO 118 MM

ROUND HALOGEN WORK LIGHT, DIAMETER 118 MM
 PHARE DE TRAVAIL HALOGÈNE ROND, DIAMÈTRE 118 MM
 RUNDER HALOGENER ARBEITSSCHEINWERFER, DURCHMESSER 118 MM
 FARO DE TRABAJO HALÓGENO REDONDO, DIÁMETRO 118 MM

**Articoli a ricambio**

01144 Lente trasparente

| Skü | Tipo luce / Light type | Tensione nominale / Rated voltage | Materiale lente / Lens material | Corpo fero / Light body | Note / Notes | Tipo lampadina / Bulb type | Prodotti compatibili / Compatible products |
|-------|------------------------|-----------------------------------|---------------------------------|---|--|----------------------------|--|
| 00903 | Alogeno / Halogen | 12-24 V | Vetro / glass | ABS con gomma antiurto / ABS with shockproof rubber | Lampadina non inclusa, con interruttore / Bulb not included, with switch | 12V 55W, 24V 70W | 00299,00446,01144 |

FARO DA LAVORO ALOGENO ROTONDO CON GOMMA ANTI-URTO

ROUND HALOGEN WORK LIGHT WITH SHOCKPROOF RUBBER
 PHARE DE TRAVAIL HALOGÈNE ROND AVEC CAOUTCHOUC ANTICHOC
 RUNDER ALOGENER ARBEITSSCHEINWERFER MIT STOSSFESTEM GUMMI
 LUZ DE TRABAJO HALÓGENO REDONDO CON GOMA ANTICHOQUE



| Skü | Tipo luce / Light type | Tensione nominale / Rated voltage | Materiale lente / Lens material | Corpo fero / Light body | Diametro esterno / Outer diameter | Note / Notes | Tipo lampadina / Bulb type | Prodotti compatibili / Compatible products |
|-------|------------------------|-----------------------------------|---------------------------------|--|-----------------------------------|---|----------------------------|--|
| 02047 | Alogeno / Halogen | 12-24 V | Vetro / Glass | ABS con gomma anti-urto / ABS with impact-resistant rubber | 124 mm | lampadina non inclusa / bulb not included | 12V 55W, 24V 70W | 00299,00446 |

FARO DA LAVORO ALOGENO ROTONDO CON MANIGLIA, INTERRUPTORE E GRIGLIA DI PROTEZIONE

ROUND HALOGEN WORK LIGHT WITH HANDLE, SWITCH, AND PROTECTIVE GRILLE
 PHARE DE TRAVAIL HALOGÈNE ROND AVEC POIGNÉE, INTERRUPTEUR ET GRILLE DE PROTECTION
 RUNDER ALOGENER ARBEITSSCHEINWERFER MIT GRIFF, SCHALTER UND SCHUTZGITTER
 LUZ DE TRABAJO HALÓGENO REDONDO CON ASA, INTERRUPTOR Y REJILLA DE PROTECCIÓN



| Skü | Tipo luce / Light type | Materiale lente / Lens material | Corpo faro / Light body | Diametro esterno / Outer diameter | Note / Notes | Tipo lampadina / Bulb type | Prodotti compatibili / Compatible products |
|-------|------------------------|---------------------------------|-------------------------|-----------------------------------|---|----------------------------|--|
| 02092 | Alogeno / Halogen | Vetro / Glass | Alluminio / Aluminium | 135 mm | lampadina non inclusa / bulb not included | 12V 55W, 24V 70W | 00299,00446 |

FARI LAVORO ALOGENI RETTANGOLARI

RECTANGULAR HALOGEN WORK LIGHTS
 PHARES DE TRAVAIL HALOGÈNES RECTANGULAIRES
 RECHTECKIGE HALOGEN-ARBEITSSCHEINWERFER
 FAROS DE TRABAJO HALÓGENOS RECTANGULARES



| Skü | Tipo luce / Light type | Tensione nominale / Rated voltage | Diametro esterno / Outer diameter | Note / Notes | Tipo lampadina / Bulb type | Prodotti compatibili / Compatible products |
|-------|------------------------|-----------------------------------|-----------------------------------|---|----------------------------|--|
| 69303 | Alogeno / Halogen | 12-24 V | 153 mm | lampadina non inclusa / bulb not included | 12V 55W, 24V 70W | 00299,00446 |

FARO DA LAVORO ALOGENO ROTONDO CON MANIGLIA E INTERRUTTORE

ROUND HALOGEN WORK LIGHT WITH HANDLE AND SWITCH
 PHARE DE TRAVAIL HALOGÈNE ROND AVEC POIGNÉE ET INTERRUPTEUR
 RUNDER ALOGENER ARBEITSSCHEINWERFER MIT GRIFF UND SCHALTER
 LUZ DE TRABAJO HALÓGENO REDONDO CON ASA Y INTERRUPTOR



| Skü | Tensione nominale / Rated voltage | Tipo luce / Light type | Materiale lente / Lens material | Corpo faro / Light body | Diametro esterno / Outer diameter | Collegamento elettrico / Electrical connection | Grado protezione ip / Degree of protection ip | Fissaggio / Fastening | Note / Notes | Tipo lampadina / Bulb type | Prodotti compatibili / Compatible products |
|-------|-----------------------------------|------------------------|---------------------------------|-------------------------|-----------------------------------|--|---|------------------------|---|----------------------------|--|
| 02084 | 12-24 V | Alogeno / Halogen | Vetro / Glass | ABS | 161 mm | Cavo / Cable | IP56 | con viti / with screws | lampadina non inclusa / bulb not included | 12V 55W, 24V 70W | 00299,00446 |

FARO DA LAVORO ALOGENO ROTONDO DIAMETRO 161 MM

ROUND HALOGEN WORK LIGHT, DIAMETER 161 MM
 PHARE DE TRAVAIL HALOGÈNE ROND, DIAMÈTRE 161 MM
 RUNDER HALOGEN-ARBEITSSCHEINWERFER, DURCHMESSER 161 MM
 FARO DE TRABAJO HALÓGENO REDONDO, DIÁMETRO 161 MM



| Skü | Tipo luce / Light type | Tensione nominale / Rated voltage | Materiale lente / Lens material | Corpo faro / Light body | Diametro esterno / Outer diameter | Collegamento elettrico / Electrical connection | Grado protezione ip / Degree of protection ip | Note / Notes | Tipo lampadina / Bulb type | Prodotti compatibili / Compatible products |
|---------|------------------------|-----------------------------------|---------------------------------|-------------------------|-----------------------------------|--|---|---|----------------------------|--|
| 0F01054 | Alogeno / Halogen | 12-24 V | vetro / glass | ABS | 161 | Cavo / Cable | IP56 | lampadina non inclusa / bulb not included | H3 | 00299,00446 |



Fanali

Lights

I prodotti recanti il marchio AMA qui indicati sono realizzati da AMA S.p.A. e destinati a essere utilizzati come ricambi adattabili e non originali. I riferimenti a marchi, codici originali e costruttori di terzi, riportati in corrispondenza degli articoli AMA compatibili, hanno esclusivamente la finalità di identificare il modello, l'applicazione o la destinazione d'uso del prodotto, in conformità a quanto previsto dal Regolamento (CE) n. 1400/2002 e dalla normativa vigente in materia di concorrenza e uso lecito dei marchi di terzi. / The products bearing the AMA brand name listed here are manufactured by AMA S.p.A. and are intended for use as adaptable, non-original spare parts. References to trademarks, original codes and third-party manufacturers, shown alongside compatible AMA items, are intended solely to identify the model, application or intended use of the product, in accordance with Regulation (EC) No. 1400/2002 and current legislation on competition and the lawful use of third-party trademarks.

FANALE DIREZIONE-POSIZIONE LED DX-SX 12V

LED DIRECTION-POSITION LIGHT RIGHT-LEFT 12V
 FEU DE POSITION-DIRECTION À LED DROIT-GAUCHE 12V
 LED-POSITIONS-/BLINKLEUCHTE RECHTS-LINKS 12V
 PILOTO LED DE POSICIÓN-DIRECCIÓN DERECHO-IZQUIERDO 12V



| Skü | Tensione nominale / Rated voltage | Lato / Side | Collegamento elettrico / Electrical connection | Fissaggio / Fastening | Dimensioni / Dimensions | Interasse fori / Hole spacing | Certificazioni / Certifications |
|-------|-----------------------------------|---------------|--|-----------------------|-------------------------|-------------------------------|---------------------------------|
| 61418 | 12 V / 12V | Dx-Sx / Rh-Lh | Cavo 100 cm / Cable 100 cm | Viti M5 / M5 Screw | 99,7x30x92,7 mm | 45 mm | ECE |

FANALE DIREZIONE-POSIZIONE LED DX-SX 12-24V

LED DIRECTION-POSITION LIGHT RIGHT-LEFT 12-14V
 FEU DE POSITION-DIRECTION À LED DROIT-GAUCHE 12-24V
 LED-POSITIONS-/BLINKLEUCHTE RECHTS-LINKS 12-24V
 PILOTO LED DE POSICIÓN-DIRECCIÓN DERECHO-IZQUIERDO 12-24V

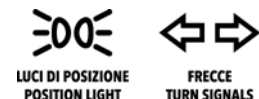

| Skü | Tensione nominale / Rated voltage | Lato / Side | Materiale lente / Lens material | Corpo faro / Light body | Collegamento elettrico / Electrical connection | Fissaggio / Fastening | Dimensioni / Dimensions | Interasse fori / Hole spacing | Certificazioni / Certifications |
|-------|-----------------------------------|---------------|---------------------------------|-------------------------|--|-----------------------|-------------------------|-------------------------------|---------------------------------|
| 61419 | 12-24 V / 12-24V | Dx-Sx / Rh-Lh | PC/PMMA | ABS | Cavo 100 cm / Cable 100 cm | Viti M5 / M5 Screw | 99,5x39,5x93 mm | 45 mm | ECE |

FANALE DIREZIONE-POSIZIONE LED ANTERIORE RETTANGOLARE

LED DIRECTION AND POSITION LIGHT, FRONT, RECTANGULAR
 FEU LED DE POSITION AVANT ET CLIGNOTANT RECTANGULAIRE
 RICHTUNGS- UND POSITIONSLICHT, VORNE, RECHTECKIG, LED
 PILOTO DELANTERO DE POSICIÓN E INTERMITENTE HALÓGENO RECTANGULAR



| Skü | Tensione nominale / Rated voltage | Lato / Side | Materiale lente / Lens material | Corpo faro / Light body | Collegamento elettrico / Electrical connection | Fissaggio / Fastening | Dimensioni / Dimensions | Interasse fori / Hole spacing | Certificazioni / Certifications |
|-------|-----------------------------------|-------------|---------------------------------|-------------------------|--|-----------------------|-------------------------|--|---------------------------------|
| 55453 | 12-24V / 12-24 V | Dx / Rh | PMMA | PP | Cavo 185 cm / Cable 185 cm | Viti M6 / M6 screw | 150x77x70 mm | Due punti di fissaggio: inferiore 110 mm, posteriore 55 mm / Two fastening points: bottom side 110 mm, rear side 55 mm | ECE |
| 55454 | 12-24V | Sx / Lh | PMMA | PP | Cavo 185 cm / Cable 185 cm | Viti M6 / M6 screw | 150x77x70 mm | Due punti di fissaggio: inferiore 110 mm, posteriore 55 mm / Two fastening points: bottom side 110 mm, rear side 55 mm | ECE |

PROIETTORI A LED RETTANGOLARI 12-24V

RECTANGULAR LED HEAD LIGHTS 12-24V
 FEUX AVANT À LED RECTANGULAIRES 12-24V
 RECHTECKIGE LED-SCHNWERFER 12-24V
 FAROS DELANTEROS LED RECTANGULARES 12-24V

1

2

3

| Skü | Pos. | Tensione nominale / Rated voltage | Lato / Side | Grado protezione ip / Degree of protection ip | Temperatura di esercizio / Operating temperature | Materiale lente / Lens material | Corpo faro / Light body | Collegamento elettrico / Electrical connection | Fissaggio / Fastening | Certificazioni / Certifications | Prodotti compatibili / Compatible products |
|-------|------|-----------------------------------|---------------|---|--|---------------------------------|-------------------------|--|-----------------------|---|--|
| 61204 | 1 | 12-24 V | Dx-Sx / Rh-Lh | IP69K | -40°C a +80°C | PC | Alluminio / Aluminium | Connettore H4 / H4 connector | Viti / Screws | ECE, EMC, CE, RoHS, REACH, CISPR 25 Class 3 | 12491 |
| 61206 | 2 | 12-24 V | Dx-Sx / Rh-Lh | IP69K | -40°C a +80°C | Vetro temprato / Glass | Alluminio / Aluminium | Connettore H4 / H4 connector | Viti / Screws | ECE, EMC, CE, RoHS, REACH, CISPR 25 Class 3 | 12491 |
| 61207 | 3 | 12-24 | Dx-Sx / Rh-Lh | IP69K | -40°C a +80°C | PC | Alluminio / Aluminium | Connettore H4 / H4 connector | Viti / Screws | ECE, EMC, CE, RoHS, REACH, CISPR 25 Class 3 | 12491 |

PROIETTORE A LED RETTANGOLARE 10-30V CON 3 ATTACCHI

RECTANGULAR LED HEAD LIGHT 10-30V WITH 3 MOUNTING POINTS
 PHARE AVANT LED RECTANGULAIRE 10-30V AVEC 3 POINTS DE FIXATION
 RECHTECKIGER LED-HAUPTSCHNWERFER 10-30V MIT 3 BEFESTIGUNGSPUNKTEN
 FARO DELANTERO LED RECTANGULAR 10-30V CON 3 PUNTOS DE FIJACIÓN

STAFFA A

STAFFA B

STAFFA C

STAFFA D

| Skü | Tensione nominale / Rated voltage | Lato / Side | Materiale lente / Lens material | Corpo faro / Light body | Collegamento elettrico / Electrical connection | Temperatura di esercizio / Operating temperature | Grado protezione ip / Degree of protection ip | Fissaggio / Fastening |
|-------|-----------------------------------|---------------|---------------------------------|-------------------------|--|--|---|---|
| 61234 | 10-30V DC | Dx-sx / RH-LH | PC | Alluminio / Aluminium | Connettore H4/ H4 connector | -40°C / +80°C | IP69K | Staffe: A, B, C, D / Brackets: A, B, C, D |

PROIETTORE A LED LENTE RISCALDATA E FRECCIA SEQUENZIALE

LED HEADLIGHT WITH HEATED LENS AND SEQUENTIAL INDICATOR
 PROJECTEUR LED AVEC LENTILLE CHAUFFANTE ET CLIGNOTANT SÉQUENTIEL
 LED-SCHWEINWERFER MIT BEHEIZTER LINSE UND SEQUENZIELLEM BLINKER
 PROYECTOR LED CON LENTE CALEFACTADA E INTERMITENTE SECUENCIAL



| Skù | Tensione nominale / Rated voltage | Lato / Side | Materiale lente / Lens material | Corpo faro / Light body | Collegamento elettrico / Electrical connection | Temperatura di esercizio / Operating temperature | Fissaggio / Fastening | Certificazioni / Certifications | Prodotti compatibili / Compatible products |
|-------|-----------------------------------|---------------|---------------------------------|-------------------------|--|--|-----------------------|--|--|
| 61236 | 12-24 V | Dx-Sx / Rh-Lh | Vetro temprato / Glass | Alluminio / Aluminium | connettore H4 / H4 connector | -40°C a +80°C | Vite M10 / M10 Screw | ECE, EMC, CE, RoHS, REACH, IP69K, CISPR 25 Class 3 | 12491 |

PROIETTORE A LED 10-30V CON FRECCIA REMOVIBILE

LED HEADLAMP 10-30 V WITH REMOVABLE INDICATOR
 PHARE AVANT À LED 10-30 V AVEC CLIGNOTANT AMOVIBLE
 LED-SCHWEINWERFER 10-30 V MIT ABNEHMBAREM BLINKER
 FARO DELANTERO LED 10-30 V CON INTERMITENTE DESMONTABLE



| Skù | Tensione nominale / Rated voltage | Lato / Side | Materiale lente / Lens material | Corpo faro / Light body | Collegamento elettrico / Electrical connection | Fissaggio / Fastening | Certificazioni / Certifications |
|-------|-----------------------------------|---------------|---------------------------------|---|--|-----------------------|--|
| 61219 | 12-24 V / 10-30V | Dx-Sx / Rh-Lh | PC | proiettore: alluminio; freccia PC / Headlight: aluminium; indicator light: PC | Proiettore: Connettore H4; Freccia: Connettore AMP 2 pin / Headlight: H4 connector; Indicator light: 2-P AMP connector | Vite M10 / M10 Screw | ECE, EMC, CE, RoHS, CISPR 25 Class 3 / CE, RoHS, REACH, IP69K, CISPR 25 Classe 3 |

KIT PROIETTORI A LED CON 3 CORNICI 12-24V

LED PROJECTOR KIT WITH 3 FRAMES 12-24V

KIT DE PROJECTEURS À LED AVEC 3 CADRES 12-24V

LED-SCHNITWERFER-KIT MIT 3 RAHMEN 12-24V

KIT DE PROYECTORES LED CON 3 MARCOS 12-24V



| Skü | Tensione nominale / Rated voltage | Lato / Side | Grado protezione ip / Degree of protection ip | Temperatura di esercizio / Operating temperature | Materiale lente / Lens material | Corpo faro / Light body | Collegamento elettrico / Electrical connection | Fissaggio / Fastening | Certificazioni / Certifications | Prodotti compatibili / Compatible products |
|-------|-----------------------------------|---------------|---|--|---------------------------------|-------------------------|--|------------------------|---------------------------------|--|
| 61215 | 12-24 V | Dx-Sx / Rh-Lh | IP69K | -40°C a +85°C | PC | Alluminio / Aluminium | Connettore H4 / H4 connector | 3 cornici / 3 brackets | ECE, EMC, CE, ROHS, REACH | 12491 |

KIT PROIETTORI A LED ROTONDI 10-30V

ROUND LED HEADLAMP KIT 10-30V

KIT DE PROJECTEURS À LED RONDS 10-30V

RUNDES LED-SCHNITWERFER-SET 10-30V

KIT DE FAROS DELANTEROS LED REDONDOS 10-30V



| Skü | Tensione nominale / Rated voltage | Lato / Side | Grado protezione ip / Degree of protection ip | Temperatura di esercizio / Operating temperature | Materiale lente / Lens material | Corpo faro / Light body | Collegamento elettrico / Electrical connection | Fissaggio / Fastening | Certificazioni / Certifications | Prodotti compatibili / Compatible products |
|-------|-----------------------------------|-------------|---|--|---------------------------------|-------------------------|--|-----------------------|---------------------------------|--|
| 61216 | 12-24 V | Dx-sx | IP69K | -40°C a +85°C | PC | Alluminio / Aluminium | Connettore H4 / H4 connector | Cornici / Bracket | ECE, EMC, CE, ROHS, REACH | 12491 |

PROIETTORE A LED DIAMETRO 133 MM

LED HEADLAMP, 133 MM DIAMETER
 PHARE AVANT LED, DIAMÈTRE 133 MM
 LED-SCHWEINWERFER, DURCHMESSER 133 MM
 FARO DELANTEROLED, DIAMETRO 133 MM



| SKU | Tensione nominale / Rated voltage | Lato / Side | Materiale lente / Lens material | Corpo faro / Light body | Collegamento elettrico / Electrical connection | Temperatura di esercizio / Operating temperature | Grado protezione ip / Degree of protection ip | Fissaggio / Fastening | Certificazioni / Certifications | Prodotti compatibili / Compatible products |
|-------|-----------------------------------|---------------|---------------------------------|-------------------------|--|--|---|---|--|--|
| 61235 | 12-24 V | Dx-Sx / Rh-Lh | PC | Alluminio / Aluminium | Connettore H4 / H4 connector | -40°C / +80°C | IP69K | Staffa A, B, C, D, E / Bracket options: A, B, C, D, E | ECE, EMC, CE, RoHS, REACH, IP69K, CISPR 25 Class 3 | 12491 |

PROIETTORI A LED QUADRATI 10-30V

SQUARE LED HEAD LIGHTS 10-30V
 PHARES AVANT LED CARRÉS 10-30V
 QUADRATISCHE LED-HAUPTSCHWEINWERFER 10-30V
 FAROS DELANTEROS LED CUADRADOS 10-30V



| SKU | Pos. | Tensione nominale / Rated voltage | Lato / Side | Grado protezione ip / Degree of protection ip | Temperatura di esercizio / Operating temperature | Materiale lente / Lens material | Corpo faro / Light body | Collegamento elettrico / Electrical connection | Fissaggio / Fastening |
|-------|------|-----------------------------------|-----------------|---|--|---------------------------------|-------------------------|--|-----------------------|
| 61237 | 1 | 10-30 V | Dx-Sx / RH / LH | IP69K | -40°C a +80°C | PC | Alluminio / Aluminium | Connettore H4 / H4 connector | Viti / Screws |
| 61238 | 2 | 10-30 V | Dx-Sx / RH - LH | IP69K | -40°C / +80°C | PC | Alluminio / Aluminum | Cavo / Cable | Viti / Screws |

FANALI ANTERIORI LED 10-30V

LED HEADLAMPS 10-30V
 PHARES AVANT À LED 10-30V
 LED-FRONTSCHEINWERFER 10-30V
 FAROS DELANTEROS LED 10-30V



| Skü | Tensione nominale / Rated voltage | Lato / Side | Materiale lente / Lens material | Corpo faro / Light body | Collegamento elettrico / Electrical connection | Fissaggio / Fastening | Certificazioni / Certifications | Prodotti compatibili / Compatible products |
|---------------|-----------------------------------|-------------|---------------------------------|-------------------------|---|-----------------------|--------------------------------------|--|
| F04214 | 12-24 V | Dx / Rh | PC | Alluminio / Aluminium | Cavo 20 cm e connettore Deutsch 6 pin / Cable 20 cm and 6-pin Deutsch connector | Vite M10 / M10 Screw | ECE, EMC, CE, RoHS, CISPR 25 Class 3 | 37889 |
| F04215 | 12-24 V | Sx / Lh | PC | Alluminio / Aluminium | Cavo 20 cm e connettore Deutsch 6 pin / Cable 20 cm and 6-pin Deutsch connector | Vite M10 / M10 Screw | ECE, EMC, CE, RoHS, CISPR 25 Class 3 | 37889 |

PROIETTORE LED 10-30V

LED HEADLIGHT 10-30V
 PROJECTEUR LED 10-30V
 LED-SCHEINWERFER 10-30V
 FARO DELANTERO 10-30V



| Skü | Tensione nominale / Rated voltage | Lato / Side | Materiale lente / Lens material | Corpo faro / Light body | Collegamento elettrico / Electrical connection | Fissaggio / Fastening | Certificazioni / Certifications | Prodotti compatibili / Compatible products |
|---------------|-----------------------------------|-------------|---------------------------------|-------------------------|---|-----------------------|--------------------------------------|--|
| F04212 | 12-24 V | Dx / Rh | PC | Alluminio / Aluminium | Cavo 20 cm e connettore Deutsch 6 pin / Cable 20 cm and 6-pin Deutsch connector | Vite M10 / M10 Screw | ECE, EMC, CE, RoHS, CISPR 25 Class 3 | 37889 |
| F04213 | 12-24 V | Sx / Lh | PC | Alluminio / Aluminium | Cavo 20 cm e connettore Deutsch 6 pin / Cable 20 cm and 6-pin Deutsch connector | Vite M10 / M10 Screw | ECE, EMC, CE, RoHS, CISPR 25 Class 3 | 37889 |

FANALI ANTERIORI LED 12-24V CON FRECCIA DINAMICA

LED HEADLAMPS 12-24V WITH DYNAMIC INDICATOR
 PHARES AVANT À LED 12-24V AVEC CLIGNOTANT DYNAMIQUE
 LED-SCHEINWERFER 12-24V MIT DYNAMISCHEM BLINKER
 FAROS DELANTEROS LED 12-24V CON INTERMITENTE DINÁMICO



| Skü | Tensione nominale / Rated voltage | Lato / Side | Grado protezione ip / Degree of protection ip | Materiale lente / Lens material | Corpo faro / Light body | Temperatura di esercizio / Operating temperature | Collegamento elettrico / Electrical connection | Fissaggio / Fastening | Certificazioni / Certifications | Prodotti compatibili / Compatible products |
|--------------|-----------------------------------|-------------|---|---------------------------------|-------------------------|--|--|-----------------------|---------------------------------|--|
| 65927 | 12-24 V | Sx / Lh | IP6K9K | PC/PMMA | Alluminio / Aluminium | -40° / +50° C | Connettore 6 pin / 6-pin connector | Vite M10 / M10 screw | EMC, ECE | 37889 |
| 65928 | 12-24 V | Dx / Rh | IP6K9K | PC/PMMA | Alluminio / Aluminium | -40° / +50° C | Connettore 6 pin / 6-pin connector | Vite M10 / M10 screw | EMC, ECE | 37889 |

PROIETTORE A LED CON FRECCIA REMOVIBILE E LENTE RISCALDATA

LED HEADLAMP WITH REMOVABLE INDICATOR AND HEATED LENS
 PROJECTEUR À LED AVEC CLIGNOTANT AMOVIBLE ET LENTILLE CHAUFFANTE
 LED-SCHNWERFER MIT ABNEHMBAREM BLINKER UND BEHEIZTER LINSE
 PROYECTOR LED CON INTERMITENTE DESMONTABLE Y LENTE CALEFACTABLE



| Skü | Tensione nominale / Rated voltage | Lato / Side | Grado protezione ip / Degree of protection ip | Temperatura di esercizio / Operating temperature | Materiale lente / Lens material | Corpo faro / Light body | Lumen | Collegamento elettrico / Electrical connection | Fissaggio / Fastening | Certificazioni / Certifications | Prodotti compatibili / Compatible products |
|-------|-----------------------------------|--|---|--|---------------------------------|-------------------------|-------------------------------------|--|-----------------------|---|--|
| 55600 | 12-24 V | Dx/Sx - freccia mobile / Rh/Lh - removable indicator | IP67, IP69K | -40°C a +60°C | Vetro / Glass | Alluminio / Aluminium | High beam: 2200LM; Low beam: 1200LM | Cavo 18 cm / Cable 18 cm | Vite M8 / M8 screw | EMC, ECE, CE, RoHS, REACH, CISPR 25 Class 3 | 37889 |

PROIETTORI ALOGENI CON INDICATORE DI DIREZIONE

HALOGEN HEADLAMPS WITH TURN SIGNAL
 PHARES AVANT HALOGÈNES AVEC CLIGNOTANT
 HALOGEN-SCHNWERFER MIT BLINKER
 FAROS DELANTEROS HALÓGENOS CON INTERMITENTE



Articoli a ricambio

| | | |
|--|--------------|---|
| | 05585 | Lente a ricambio per indicatore di direzione per art. 05538 |
| | 05586 | Lente a ricambio per indicatore di direzione per art. 05539 |
| | 37889 | Kit completo connettore |

| Skü | Tensione nominale / Rated voltage | Lato / Side | Interasse fori / Hole spacing | Fissaggio / Fastening | Collegamento elettrico / Electrical connection | Note / Notes | Certificazioni / Certifications | Prodotti compatibili / Compatible products |
|--------|-----------------------------------|-------------|-------------------------------|--|---|------------------------------------|---------------------------------|--|
| 12955 | 12 V | Dx / Rh | 60 mm | Viti M8x30 mm (sotto al fanale) / M8x30 mm screws (bottom of headlamp) | Connettore Connex 6 poli / Connex 6-pin connector | Lampadine incluse / Bulbs included | ECE | 00373,00441,00451,05538,12491,F04142 |
| 12956 | 12 V | Sx / Lh | 60 mm | Viti M8x30 mm (sotto al fanale) / M8x30 mm screws (bottom of headlamp) | Connettore Connex 6 poli / Connex 6-pin connector | Lampadine incluse / Bulbs included | ECE | 00373,00441,00451,05539,12491,F04142 |
| F04154 | 24 V | Dx / Rh | 60 mm | Viti M8x30 mm (sotto al fanale) / M8x30 mm screws (bottom of headlamp) | Connettore Connex 6 poli / Connex 6-pin connector | Lampadine incluse / Bulbs included | ECE | 00375,00525,04019,05538,12491,F04142 |
| F04155 | 24 V | Sx / Lh | 60 mm | Viti M8x30 mm (sotto al fanale) / M8x30 mm screws (bottom of headlamp) | Connettore Connex 6 poli / Connex 6-pin connector | Lampadine incluse / Bulbs included | ECE | 00375,00525,04019,05539,12491,F04142 |

FANALI ANTERIORI 12V ATTACCO POSTERIORE

FRONT HEADLAMPS 12V WITH REAR MOUNTING
 PHARES AVANT 12V AVEC FIXATION ARRIÈRE
 12V-FRONTSCHEINWERFER MIT RÜCKSEITIGER BEFESTIGUNG
 FAROS DELANTEROS 12V CON FIJACIÓN TRASERA

Articoli a ricambio

05585 Lente a ricambio per indicatore di direzione per art. 05538



05586 Lente a ricambio per indicatore di direzione per art. 05539

| Skù | Tensione nominale / Rated voltage | Lato / Side | Interasse fori / Hole spacing | Fissaggio / Fastening | Collegamento elettrico / Electrical connection | Note / Notes | Certificazioni / Certifications | Prodotti compatibili / Compatible products |
|-------|-----------------------------------|-------------|-------------------------------|--|---|------------------------------------|---------------------------------|--|
| 55354 | 12 V | Dx / Rh | 60 mm | Viti M8x30 mm (sul retro del fanale) / M8x30 mm screws (at the back of the headlamp) | Connettore Connex 6 poli / Connex 6-pin connector | Lampadine incluse / Bulbs included | ECE | 00373,00441,00451,05538,12491,F04142 |
| 55355 | 12 V | Sx / Lh | 60 mm | Viti M8x30 mm (sul retro del fanale) / M8x30 mm screws (at the back of the headlamp) | Connettore Connex 6 poli / Connex 6-pin connector | Lampadine incluse / Bulbs included | ECE | 00373,00441,00451,05539,12491,F04142 |

PROIETTORI ALOGENI CON INDICATORE DI DIREZIONE

HALOGEN HEADLAMPS WITH TURN SIGNAL
 PHARES AVANT HALOGÈNES AVEC CLIGNOTANT
 HALOGEN-SCHEINWERFER MIT BLINKER
 FAROS DELANTEROS HALÓGENOS CON INTERMITENTE

Articoli a ricambio

05585 Lente a ricambio per indicatore di direzione per art. 05538



05586 Lente a ricambio per indicatore di direzione per art. 05539

| Skù | Tensione nominale / Rated voltage | Lato / Side | Dimensioni / Dimensions | Interasse fori / Hole spacing | Collegamento elettrico / Electrical connection | Fissaggio / Fastening | Omologazioni / Homologations | Note / Notes | Prodotti compatibili / Compatible products |
|-------|-----------------------------------|-------------|-------------------------|-------------------------------|--|---------------------------------|------------------------------|--|--|
| 04219 | 12 V | Dx / Rh | 235x135x143 mm | 60 mm | Connettore / Connector | Viti ø 8,5 mm / Screws ø 8,5 mm | ECE | Lampadine 12V incluse / 12V bulbs included | 00295,00441,00451,02582,05538,12589 |
| 05607 | 12 V | Sx / Lh | 235x135x143 mm | 60 mm | Connettore / Connector | Viti ø 8,5 mm / Screws ø 8,5 mm | ECE | Lampadine 12V incluse / 12V bulbs included | 00295,00441,00451,02582,05539,12589 |

PROIETTORI ALOGENI CON INDICATORE DI DIREZIONE HELLA

HALOGEN HEADLAMPS WITH TURN SIGNAL HELLA
 PHARES AVANT HALOGÈNES AVEC CLIGNOTANT HELLA
 HALOGEN-SCHEINWERFER MIT BLINKER HELLA
 FAROS DELANTEROS HALÓGENOS CON INTERMITENTE HELLA



| Skü | Brand / Brand | Modello / Model | Tensione nominale / Rated voltage | Lato / Side | Dimensioni / Dimensions | Fissaggio / Fastening | Collegamento elettrico / Electrical connection | Interasse fori / Hole spacing | Note / Notes | Certificazioni / Certifications | Prodotti compatibili / Compatible products |
|-------|---------------|-----------------|-----------------------------------|-------------|-------------------------|-----------------------|--|-------------------------------|------------------------------------|---------------------------------|--|
| 64596 | Hella | COMBI 120 | 12 V | Sx / Lh | 304,5x146x153,3 mm | Viti M8 / M8 screws | Connettore / Connector | 60 mm | Lampadine incluse / Bulbs included | ECE | 00373,00441, 00451,37889 |
| 64597 | Hella | COMBI 120 | 12 V | Dx / Rh | 304,5x146x153,3 mm | Viti M8 / M8 screws | Connettore / Connector | 60 mm | Lampadine incluse / Bulbs included | ECE | 00373,00441, 00451,37889 |

FANALE ANTERIORE ALOGENO RETTANGOLARE

RECTANGULAR HALOGEN PROJECTOR
 PROJECTEUR HALOGÈNE RECTANGULAIRE
 RECHTECKIGER HALOGENSCHEINWERFER
 PROYECTOR HALÓGENO RECTANGULAR



1



2

| Skü | Pos. | Brand / Brand | Tensione nominale / Rated voltage | Lato / Side | Dimensioni / Dimensions | Fissaggio / Fastening | Collegamento elettrico / Electrical connection | Note / Notes | Certificazioni / Certifications | Prodotti compatibili / Compatible products |
|--------|------|---------------|-----------------------------------|-------------|-------------------------|-----------------------|--|--|---------------------------------|--|
| F04096 | 1 | Hella | 12-24 V | Sx / Lh | 212x101x150 mm | Vite M12 / M12 screws | Connettore AMP 6 poli / AMP 6-pin connector | Lampadine 12V incluse / Bulbs 12V included | ECE | 00441,00451, 12589,34536 |
| F04097 | 2 | Hella | 12-24 V | Dx / Rh | 212x101x150 mm | Vite M12 / M12 screws | Connettore AMP 6 poli / AMP 6-pin connector | Lampadine 12V incluse / Bulbs 12V included | ECE | 00441,00451, 12589,34537 |

PROIETTORI ALOGENI CON INDICATORE DI DIREZIONE

HALOGEN HEADLAMPS WITH TURN SIGNAL
 PHARES AVANT HALOGÈNES AVEC CLIGNOTANT
 HALOGEN-SCHEINWERFER MIT BLINKER
 FAROS DELANTEROS HALÓGENOS CON INTERMITENTE



| Skü | Tensione nominale / Rated voltage | Lato / Side | Dimensioni / Dimensions | Collegamento elettrico / Electrical connection | Fissaggio / Fastening | Note / Notes | Prodotti compatibili / Compatible products |
|-------|-----------------------------------|---------------|-------------------------|--|-----------------------|--|--|
| 69318 | 12-24 V | Dx-Sx / Rh-Lh | 150,4x124,6x212 mm | Connettore / Connector | Vite M12 / M12 screw | Lampadine non incluse / Bulbs not included | 00375,00441,00451,00525,04019,34536,37889 |

PROIETTORI ALOGENI CON INDICATORE DI DIREZIONE

HALOGEN HEADLAMPS WITH TURN SIGNAL
 PHARES AVANT HALOGÈNES AVEC CLIGNOTANT
 HALOGEN-SCHEINWERFER MIT BLINKER
 FAROS DELANTEROS HALÓGENOS CON INTERMITENTE



| Skü | Tensione nominale / Rated voltage | Lato / Side | Dimensioni / Dimensions | Collegamento elettrico / Electrical connection | Fissaggio / Fastening | Note / Notes | Prodotti compatibili / Compatible products |
|--------------|-----------------------------------|---------------|-------------------------|--|-----------------------|--|--|
| 69345 | 12-24 V | Dx-Sx / Rh-Lh | 154,83x120x211,69 mm | passacavo / grommet | Vite M12 / M12 screw | Lampadine non incluse / Bulbs not included | 00295,00441,00451 |

PROIETTORI ALOGENI SIMMETRICI COBO

SYMMETRIC HALOGEN HEADLAMPS COBO
 PHARES HALOGÈNES SYMÉTRIQUES COBO
 SYMMETRISCHE HALOGEN-SCHEINWERFER COBO
 FAROS HALÓGENOS SIMÉTRICOS COBO

Articoli a ricambio

| | | | |
|--|--------------|--------------------------------|-------------------------|
| | 00791 | Cornice nera | 01468,01469,01470 |
| | 00792 | Rodovetro quadrato in plastica | 01468,01469,01470,01621 |
| | 00833 | Cornice cromata | 01621 |

| Skü | Pos. | Brand / Brand | Tensione nominale / Rated voltage | Lato / Side | Dimensioni / Dimensions | Fissaggio / Fastening | Collegamento elettrico / Electrical connection | Note / Notes | Certificazioni / Certifications | Prodotti compatibili / Compatible products |
|--------------|------|---------------|-----------------------------------|---------------|-------------------------|-----------------------|--|--|---------------------------------|--|
| 01468 | 1-2 | Cobo | 12-24 V | Dx-Sx / Rh-Lh | 140x81x140 mm | a molla / with spring | Presä bassa / Low socket | Lampadine non incluse / Bulbs non included | ECE | 00391,00439,00451,00525,00791,00792 |
| 01469 | 3-4 | Cobo | 12-24 V | Dx-Sx / Rh-Lh | 140x81x140 mm | a molla / with spring | Presä bassa / Low socket | Lampadine non incluse / Bulbs non included | ECE | 00391,00439,00451,00525,00791,00792 |
| 01470 | 5-6 | Cobo | 12-24 V | Dx-Sx / Rh-Lh | 140x81x140 mm | a molla / with spring | Presä alta / High socket | Lampadine non incluse / Bulbs non included | ECE | 00391,00439,00451,00525,00791,00792 |
| 01621 | 7-8 | Cobo | 12-24 V | Dx-Sx / Rh-Lh | 140x81x140 mm | a vite / with screw | Presä bassa / Low socket | Lampadine non incluse / Bulbs non included | ECE | 00391,00439,00451,00525,00792,00833 |

GRUPPO OTTICO ALOGENO

HALOGEN HEADLIGHT UNIT
BLOC OPTIQUE HALOGÈNE
HALOGEN-SCHEINWERFEREINHEIT
GRUPO ÓPTICO HALÓGENO



| Skü | Pos. | Tensione nominale / Rated voltage | Lato / Side | Diametro / Diameter | Collegamento elettrico / Electrical connection | Fissaggio / Fastening | Note / Notes | Prodotti compatibili / Compatible products |
|-------|-------|--------------------------------------|---------------|------------------------|---|--|---|---|
| 42847 | 1 / 1 | 12-24 V | Dx-Sx / Rh-Lh | 136 mm | Faston 6,3 mm / 6.3 mm Faston | a incasso con viti / recessed with screws | Lampadina non inclusa / Bulbs not included | 00295,L26012 |

PROIETTORI ALOGENO DIAMETRO 140 MM

HALOGEN PROJECTOR, DIAMETER 140 MM
PROJECTEUR HALOGÈNE, DIAMÈTRE 140 MM
HALOGEN-SCHEINWERFER, DURCHMESSER 140 MM
PROYECTOR HALÓGENO, DIAMETRO 140 MM



| Skü | Brand / Brand | Tensione nominale / Rated voltage | Lato / Side | Diametro / Diameter | Collegamento elettrico / Electrical connection | Fissaggio / Fastening | Note / Notes | Certificazioni / Certifications | Prodotti compa- tibili / Compatible products |
|------------|------------------|---|-------------|------------------------|---|--------------------------|--|------------------------------------|--|
| CB05272000 | Cobo | 12-24 V | Dx / Rh | 140 mm | Faston 6,3 mm / 6,3 mm Faston | 3 viti / screws | Lampadine non include / Bulbs not included | ECE | 00295,L26012 |

PROIETTORE ALOGENO

HALOGEN HEADLAMP
PHARE AVANT HALOGÈNE
HALOGEN-SCHEINWERFER
FARO DELANTERO HALÓGENO



| Skü | Tensione nominale / Rated voltage | Lato / Side | Diametro / Diameter | Collegamento elettrico / Electrical connection | Fissaggio / Fastening | Note / Notes | Certificazioni / Certifications | Prodotti compatibili / Compatible products |
|--------------|-----------------------------------|---------------|---------------------|--|-----------------------|--|---------------------------------|--|
| 02849 | 12-24 V | Dx-Sx / Rh-Lh | 161 mm | Faston 6,3 mm / 6,3 mm Faston | vite M18 / M18 screw | Lampadine non incluse / Bulbs not included | ECE | 00373,00451 |

PROIETTORE ALOGENO

HALOGEN HEADLAMP, 161 MM DIAMETER
PHARE AVANT HALOGÈNE, DIAMÈTRE 161 MM
HALOGEN-SCHEINWERFER, DURCHMESSER 161 MM
FARO DELANTERO HALÓGENO



| Skü | Tensione nominale / Rated voltage | Lato / Side | Diametro / Diameter | Collegamento elettrico / Electrical connection | Fissaggio / Fastening | Note / Notes | Prodotti compatibili / Compatible products |
|--------------|-----------------------------------|---------------|---------------------|--|-----------------------|--|--|
| 02850 | 12-24 V | Dx-Sx / Rh-Lh | 153 mm | faston 6,3 mm / 6,3 mm Faston | Vite M16 / M16 screw | Lampadine non incluse / Bulbs not included | 00295,00451,00525,L26012 |

PROIETTORE ALOGENO DIAMETRO 153 MM

HALOGEN HEADLAMP, 153 MM DIAMETER
PHARE AVANT HALOGÈNE, DIAMÈTRE 153 MM
HALOGEN-SCHEINWERFER, DURCHMESSER 153 MM
FARO DELANTERO HALÓGENO, DIÁMETRO 153 MM



| Skü | Tensione nominale / Rated voltage | Lato / Side | Diametro / Diameter | Colore / Colour | Fissaggio / Fastening | Collegamento elettrico / Electrical connection | Note / Notes | Prodotti compatibili / Compatible products |
|--------------|-----------------------------------|---------------|---------------------|-----------------|-----------------------|--|--|--|
| 02859 | 12-24 V | Dx-Sx / Rh-Lh | 154 mm | blu / blue | Vite M16 / M16 screw | faston 6,3 mm / 6,3 mm Faston | Lampadine non incluse / Bulbs not included | 00295,00451,00525,L26012 |

PROIETTORI ALOGENI ARANCIO TIPO CNH

ORANGE HALOGEN PROJECTORS, CNH TYPE
 PROJECTEURS HALOGÈNES ORANGE, TYPE CNH
 ORANGEFARBENE HALOGEN-SCHEINWERFER, CNH-TYP
 PROYECTORES HALÓGENOS NARANJAS, TIPO CNH



1



2



3



Articoli a ricambio

| | | |
|--|--------------|---------------------|
| | 08822 | Supporto per fanale |
| | 08836 | Gruppo ottico dx/sx |

| Skù | Pos. | Tensione nominale / Rated voltage | Lato / Side | Collegamento elettrico / Electrical connection | Contenuto / Content | Modello / Model | Note / Notes | Prodotti compatibili / Compatible products |
|----------------|------|-----------------------------------|-----------------|--|--|---|------------------------------------|--|
| 08805 | 1 | 12V | Dx / Rh | Cavo 30 cm / Cable 30 cm | Proiettore dx / Rh headlamp | Compatibile con FIAT 5118925 / Compatible with FIAT 5118925 | Lampadine incluse / Bulbs included | 00439,00451,08822,08836 |
| 08805CS | 2 | 12V | Dx e Sx / Rh&Lh | Cavo 30 cm / Cable 30 cm | Proiettore dx, Proiettore sx, n. 2 supporti / Rh headlamp, Lh headlamp, 2 supports | Compatibile con FIAT 5118924, FIAT 5118925, FIAT 4951145 | Lampadine incluse / Bulbs included | 00440,00451,08822,08836 |
| 08806 | 3 | 12V | Sx / Lh | Cavo 30 cm / Cable 30 cm | Proiettore sx / Lh headlamp | Compatibile con FIAT 5118925 / Compatible with FIAT 5118925 | Lampadine incluse / Bulbs included | 00441,00451,08822,08836 |

PROIETTORE ALOGENO ASIMMETTRICO

ASYMMETRIC HALOGEN HEADLAMP
 PHARE HALOGÈNE ASYMÉTRIQUE
 ASYMMETRISCHER HALOGEN-SCHEINWERFER
 FARO HALÓGENO ASIMÉTRICO



| Skù | Tensione nominale / Rated voltage | Lato / Side | Dimensioni / Dimensions | Note / Notes | Certificazioni / Certifications | Prodotti compatibili / Compatible products |
|--------------|-----------------------------------|---------------|-------------------------|---|---------------------------------|--|
| 02811 | 12-24V | Dx-Sx / Rh-Lh | 151,5x85x152,5 mm | Lampadina non inclusa / Bulb not included | ECE | 00295,L26012 |

PROIETTORI ALOGENI

 HALOGEN HEADLAMPS
 PHARES AVANT HALOGÈNES
 HALOGEN-SCHEINWERFER
 FAROS DELANTEROS HALÓGENOS

1

2

3

4

| Skü | Pos. | Tensione nominale / Rated voltage | Funzioni / Functions | Lato / Side | Dimensioni / Dimensions | Fissaggio / Fastening | Note / Notes | Certificazioni / Certifications | Prodotti compatibili / Compatible products |
|--------------|------|-----------------------------------|---|---------------|-------------------------|--|--|---------------------------------|--|
| 01364 | 1 | 12-24 V | Abbagliante, anabbagliante / High beam, low beam | Dx-Sx / Rh-Lh | 155x90x102 mm | interasse 120x110 mm / hole spacing 120x110 mm | Lampadine non incluse / Bulb not included | ECE | 00295,L26012 |
| 03988 | 1 | 12-24 V | Luce di posizione, abbagliante, anabbagliante / Position light, high beam, low beam | Dx-Sx / Rh-Lh | 155x90x102 mm | interasse 120x110 mm / hole spacing 120x110 mm | Lampadine non incluse / Bulbs not included | ECE | 00295,00451,00525,L26012 |
| 26487 | 2 | 12-24 V | Abbagliante, anabbagliante / High beam, low beam | Dx-Sx / Rh-Lh | 185x130x95 mm | interasse 130x140 mm / hole spacing 130x140 mm | Lampadine non incluse / Bulb not included | ECE | 00295,00451 |
| 26946 | 3 | 12-24 V | Abbagliante, anabbagliante / High beam, low beam | Dx-Sx / Rh-Lh | 193x135x95 mm | interasse 120x170 mm / hole spacing 120x170 mm | Lampadine non incluse / Adaptable to original FIAT reference 5154453 | ECE | 00295,00451 |
| 27238 | 4 | 12-24 V | Luce di posizione, abbagliante, anabbagliante / Position light, high beam, low beam | Dx-Sx / Rh-Lh | 184x110x102 mm | vite M10 / M10 screw | Lampadine non incluse / IP54 | ECE | 00373,00375,00451,00525 |

PROIETTORE ALOGENO

 HALOGEN HEADLAMP
 PHARE AVANT HALOGÈNE
 HALOGEN-SCHEINWERFER
 FARO DELANTERO HALÓGENO

| Skü | Tensione nominale / Rated voltage | Lato / Side | Dimensioni / Dimensions | Interasse fori / Hole spacing | Note / Notes | Certificazioni / Certifications |
|---------------|-----------------------------------|---------------|-------------------------|-------------------------------|--|---------------------------------|
| F04142 | 12-24 V | Dx-Sx / Rh-Lh | 175x88x104 mm | 165x74 mm | Lampadine non incluse / Bulbs not included | ECE |

PROIETTORE ALOGENO

HALOGEN HEADLAMP
PHARE AVANT HALOGÈNE
HALOGEN-SCHEINWERFER
FARO DELANTERO HALÓGENO



| Skü | Tensione nominale / Rated voltage | Lato / Side | Dimensioni / Dimensions | Note / Notes | Prodotti compatibili / Compatible products |
|-------|-----------------------------------|---------------|-------------------------|--|--|
| 02860 | 12-24 V | Dx-Sx / Rh-Lh | 191x114x135 mm | Lampadine non incluse / Bulbs not included | 00295,L26012 |

PROIETTORE ALOGENO DIAMETRO 153 MM

HALOGEN PROJECTOR, DIAMETER 153 MM
PROJECTEUR HALOGÈNE, DIAMÈTRE 153 MM
HALOGEN-SCHEINWERFER, DURCHMESSER 153 MM
PROYECTOR HALÓGENO, DIÁMETRO 153 MM



| Skü | Tensione nominale / Rated voltage | Dimensioni / Dimensions | Fissaggio / Fastening | Collegamento elettrico / Electrical connection | Note / Notes | Prodotti compatibili / Compatible products |
|-------|-----------------------------------|-------------------------|-----------------------|--|---|--|
| 42019 | 12-24V | 168x100x108 mm | viti / screws | faston 6,3 mm / 6,3 mm Faston | Lampadina non incluse / Bulb not included | 00295,L26012 |

PROIETTORI ALOGENI COBO

HALOGEN HEADLAMPS COBO
PHARES AVANT HALOGÈNES COBO
HALOGEN-SCHEINWERFER COBO
FAROS DELANTEROS HALÓGENOS COBO



1

2



| Skü | Pos. | Tensione nominale / Rated voltage | Lato / Side | Dimensioni / Dimensions | Interasse fori / Hole spacing | Collegamento elettrico / Electrical connection | Note / Notes | Certificazioni / Certifications | Prodotti compatibili / Compatible products |
|--------|-------|-----------------------------------|---------------|-------------------------|-------------------------------|--|--|---------------------------------|--|
| 09860 | 1 / 1 | 12-24 V | Dx-Sx / Rh-Lh | 183x97x102 mm | 160 mm | faston 6,3 mm / 6,3 mm faston | Lampadine non incluse / Bulbs not included | ECE | 00373,00375,00451,00525 |
| 17270 | 2 / 2 | 12-24 V | Dx-Sx / Rh-Lh | 155x86x92 mm | 165 - 49 mm | faston 6,3 mm / 6,3 mm faston | Lampadine non incluse / Bulbs not included | ECE | 00373,00375,00451,00525 |
| F04124 | 2 / 1 | 12-24V | Dx-Sx / Rh-Lh | 155x86x92 mm | 165 - 49 mm | faston 6,3 mm / 6,3 mm faston | Lampadine non incluse / Bulbs not included | ECE | 00373,00375 |

PROIETTORE ALOGENO

HALOGEN HEADLAMP
PHARE AVANT HALOGÈNE
HALOGEN-SCHEINWERFER
FARO DELANTERO HALÓGENO





| Skü | Tensione nominale / Rated voltage | Lato / Side | Dimensioni / Dimensions | Modello / Model | Interasse fori / Hole spacing | Note / Notes | Prodotti compatibili / Compatible products |
|-------|-----------------------------------|---------------|-------------------------|---|-------------------------------|--|--|
| 01418 | 12-24 V | Dx-Sx / Rh-Lh | 130x84x60,5 mm | compatibile con trattori e motocoltivatori Pasquali, Valpadana, Ferrari / For Pasquali, Valpadana and Ferrari tractors and walking tractors | 138,5 mm | Lampadine non incluse / Bulbs not included | 00391,00439,00451,00525 |

FANALE DIREZIONE-POSIZIONE ALOGENO ANTERIORE RETTANGOLARE

DIRECTION AND POSITION LIGHT HALOGEN, FRONT, RECTANGULAR
FEU DE POSITION AVANT ET CLIGNOTANT RECTANGULAIRE HALOGÈNE
RICHTUNGS- UND POSITIONSLICHT, VORNE, RECHTECKIG, HALOGEN
PILOTO DELANTERO DE POSICIÓN E INTERMITENTE HALÓGENO RECTANGULAR

Articoli a ricambio

| | | |
|---|--------------|-----------------------------|
|  | 00807 | Lente a ricambio anteriore |
|  | 02270 | Scarpetta posteriore fanale |

| Skü | Tensione nominale / Rated voltage | Lato / Side | Dimensioni / Dimensions | Interasse fori / Hole spacing | Collegamento elettrico / Electrical connection | Note / Notes | Certificazioni / Certifications | Prodotti compatibili / Compatible products |
|-------|-----------------------------------|---------------|-------------------------|-------------------------------|--|--|---------------------------------|--|
| 00464 | 12-24 V | Dx-Sx / Rh-Lh | 120x56x90 mm | 58 mm | passacavo / grommet | Lampadine non incluse / Bulbs not included | ECE | 00397,00441,00524,04019 |

FANALE DIREZIONE-POSIZIONE ALOGENO ANTERIORE RETTANGOLARE CON ATTACCO LATERALE

DIRECTION AND POSITION LIGHT HALOGEN, FRONT, RECTANGULAR AND LATERAL MOUNT
 FEU DE POSITION AVANT ET CLIGNOTANT RECTANGULAIRE HALOGENE AVEC MONTAGE LATÉRAL
 RICHTUNGS- UND POSITIONSLICHT, VORNE, RECHTECKIG, HALOGEN MIT SEITLICHER BEFESTIGUNG
 PILOTO DELANTERO DE POSICIÓN E INTERMITENTE HALÓGENO RECTANGULAR CON SOPORTE LATERAL

Articoli a ricambio

00807 Lente a ricambio anteriore

| Skù | Tensione nominale / Rated voltage | Lato / Side | Dimensioni / Dimensions | Interasse fori / Hole spacing | Collegamento elettrico / Electrical connection | Note / Notes | Certificazioni / Certifications | Prodotti compatibili / Compatible products |
|--------------|-----------------------------------|-------------|-------------------------|-------------------------------|--|--|---------------------------------|--|
| 12334 | 12-24 V | Sx / Lh | 120x56x80 mm | 50 mm | passacavo / grommet | Lampadine non incluse / Bulbs not included | ECE | 00397,00441,00524,00807,04019 |
| 12335 | 12-24 V | Dx / Rh | 120x56x80 mm | 50 mm | passacavo / grommet | Lampadine non incluse / Bulbs not included | ECE | 00397,00441,00524,00807,04019 |

FANALE DIREZIONE-POSIZIONE ALOGENO ANTERIORE RETTANGOLARE

DIRECTION AND POSITION LIGHT HALOGEN, FRONT, RECTANGULAR
 FEU DE POSITION AVANT ET CLIGNOTANT RECTANGULAIRE HALOGENE
 RICHTUNGS- UND POSITIONSLICHT, VORNE, RECHTECKIG, HALOGEN
 PILOTO DELANTERO DE POSICIÓN E INTERMITENTE HALÓGENO RECTANGULAR

Articoli a ricambio

00807 Lente a ricambio anteriore



02270 Scarpetta posteriore fanale

| Skù | Tensione nominale / Rated voltage | Lato / Side | Collegamento elettrico / Electrical connection | Note / Notes | Certificazioni / Certifications | Prodotti compatibili / Compatible products |
|--------------|-----------------------------------|---------------|--|--|---------------------------------|--|
| 02862 | 12-24 V | Dx-Sx / Rh-Lh | passacavo / grommet | Lampadine non incluse / Bulbs not included | ECE | 00397,00441,00524,04019 |

FANALE DIREZIONE-POSIZIONE ALOGENO ANTERIORE RETTANGOLARE

DIRECTION AND POSITION LIGHT HALOGEN, FRONT, RECTANGULAR
 FEU DE POSITION AVANT ET CLIGNOTANT RECTANGULAIRE HALOGENE
 RICHTUNGS- UND POSITIONSLICHT, VORNE, RECHTECKIG, HALOGEN
 PILOTO DELANTERO DE POSICIÓN E INTERMITENTE HALÓGENO RECTANGULAR

Articoli a ricambio

00807 Lente a ricambio anteriore



02951 Lente a ricambio posteriore

| Skù | Tensione nominale / Rated voltage | Funzioni / Functions | Lato / Side | Dimensioni / Dimensions | Interasse fori / Hole spacing | Collegamento elettrico / Electrical connection | Note / Notes | Certificazioni / Certifications | Prodotti compatibili / Compatible products |
|--------------|-----------------------------------|---|---------------|-------------------------|-------------------------------|--|--|---------------------------------|---|
| 03579 | 12-24 V | Luce di posizione anteriore, indicatore di direzione anteriore e Luce di posizione e luce stop posteriore, luce di direzione posteriore | Dx-Sx / Rh-Lh | 120x136x80 mm | 53 mm | passacavo / grommet | Lampadine non incluse / Bulbs not included | ECE | 00397,00440,0 0441,00501,00 524,04019 |

FANALE DIREZIONE-POSIZIONE ALOGENO ANTERIORE QUADRATO

DIRECTION AND POSITION LIGHT HALOGEN, FRONT, RECTANGULAR
 FEU DE POSITION AVANT ET CLIGNOTANT CARRÉ HALOGENE
 RICHTUNGS- UND POSITIONSLICHT, VORNE, QUADRATISCHES, HALOGEN
 PILOTO DELANTERO DE POSICIÓN E INTERMITENTE HALÓGENO CUADRADO

Articoli a ricambio

09859 Lente a ricambio

| Skù | Tensione nominale / Rated voltage | Lato / Side | Dimensioni / Dimensions | Interasse fori / Hole spacing | Collegamento elettrico / Electrical connection | Note / Notes | Certificazioni / Certifications | Prodotti compatibili / Compatible products |
|--------------|-----------------------------------|---------------|-------------------------|-------------------------------|--|--|---------------------------------|--|
| 09869 | 12-24 V | Dx-Sx / Rh-Lh | 84x62x83 mm | 45 mm | passacavo / grommet | Lampadine non incluse / Bulbs not included | ECE | 00277,00441,00526,04019,09859 |

FANALE DIREZIONE-POSIZIONE ALOGENO ANTERIORE QUADRATO COBO

DIRECTION AND POSITION LIGHT HALOGEN, FRONT, SQUARE, COBO
 FEU DE POSITION AVANT ET CLIGNOTANT CARRÉ HALOGÈNE COBO
 RICHTUNGS- UND POSITIONSLICHT, VORNE, QUADRATISCHES, HALOGEN COBO
 PILOTO DELANTERO DE POSICIÓN E INTERMITENTE HALÓGENO RECTANGULAR COBO

Articoli a ricambio

00751 Lente a ricambio

| Skù | Brand / Brand | Tensione nominale / Rated voltage | Lato / Side | Dimensioni / Dimensions | Collegamento elettrico / Electrical connection | Note / Notes | Certificazioni / Certifications | Prodotti compatibili / Compatible products |
|-------|---------------|-----------------------------------|---------------|-------------------------|--|--|---------------------------------|--|
| 00750 | Cobo | 12-24 V | Dx-Sx / Rh-Lh | 188x100x140 mm | passacavo / grommet | Lampadine non incluse / Bulbs not included | ECE | 00397,00441,00524,00751,04019 |

FANALE DIREZIONE-POSIZIONE ALOGENO ANTERIORE QUADRATO

DIRECTION AND POSITION LIGHT HALOGEN, FRONT, SQUARE
 FEU DE POSITION AVANT ET CLIGNOTANT CARRÉ HALOGÈNE
 RICHTUNGS- UND POSITIONSLICHT, VORNE, QUADRATISCHES, HALOGEN
 PILOTO DELANTERO DE POSICIÓN E INTERMITENTE HALÓGENO CUADRADO

Articoli a ricambio

12532 Lente a ricambio

| Skù | Tensione nominale / Rated voltage | Lato / Side | Dimensioni / Dimensions | Interasse fori / Hole spacing | Collegamento elettrico / Electrical connection | Note / Notes | Certificazioni / Certifications | Prodotti compatibili / Compatible products |
|-------|-----------------------------------|---------------|-------------------------|-------------------------------|--|--|---------------------------------|--|
| 12531 | 12-24 V | Dx-Sx / Rh-Lh | 110x51x102 mm | 55 mm | passacavo / grommet | Lampadine non incluse / Bulbs not included | ECE | 00277,00441,00526,04019,12532 |

FANALE DIREZIONE-POSIZIONE ALOGENO ANTERIORE RETTANGOLARE

DIRECTION AND POSITION LIGHT HALOGEN, FRONT, RECTANGULAR
 FEU DE POSITION AVANT ET CLIGNOTANT RECTANGULAIRE HALOGÈNE
 RICHTUNGS- UND POSITIONSLICHT, VORNE, RECHTECKIG, HALOGEN
 PILOTO DELANTERO DE POSICIÓN E INTERMITENTE HALÓGENO

Articoli a ricambio

02858 Lente a ricambio

| Skü | Tensione nominale / Rated voltage | Lato / Side | Dimensioni / Dimensions | Interasse fori / Hole spacing | Collegamento elettrico / Electrical connection | Note / Notes | Certificazioni / Certifications | Prodotti compatibili / Compatible products |
|--------------|-----------------------------------|---------------|-------------------------|-------------------------------|--|--|---------------------------------|--|
| 85445 | 12-24 V | Dx-Sx / Rh-Lh | 149x60,5x68 mm | 55 mm | passacavo / grommet | Lampadine non incluse / Bulbs not included | ECE | 00397,00441,00524,02858,04019 |

FANALE DIREZIONE-POSIZIONE ALOGENO ANTERIORE RETTANGOLARE COMPATIBILE FORD

DIRECTION AND POSITION LIGHT HALOGEN, FRONT, RECTANGULAR FORD COMPATIBLE
 FEU DE POSITION AVANT ET CLIGNOTANT RECTANGULAIRE HALOGÈNE COMPATIBLE FORD
 RICHTUNGS- UND POSITIONSLICHT, VORNE, RECHTECKIG, HALOGEN, FORD-KOMPATIBEL
 PILOTO DELANTERO DE POSICIÓN E INTERMITENTE HALÓGENO RECTANGULAR, COMPATIBLE FORD

Articoli a ricambio

22030 Lente a ricambio anteriore per art. 22027 e art. 22028

| Skü | Tensione nominale / Rated voltage | Lato / Side | Dimensioni / Dimensions | Interasse fori / Hole spacing | Collegamento elettrico / Electrical connection | Certificazioni / Certifications | Note / Notes | Prodotti compatibili / Compatible products |
|--------------|-----------------------------------|-------------|-------------------------|-------------------------------|--|---------------------------------|--|--|
| 22027 | 12-24 V | Dx / Rh | 164x151x90 mm | 112,5 mm | passacavo / grommet | ECE | Lampadine non incluse / Bulbs not included | 00397,00441,00524,04019 |
| 22028 | 12-24 V | Sx / Lh | 164x151x90 mm | 112,5 mm | passacavo / grommet | ECE | Lampadine non incluse / Bulbs not included | 00397,00441,00524,04019 |

FANALE DIREZIONE-POSIZIONE ALOGENO ANTERIORE RETTANGOLARE

DIRECTION AND POSITION LIGHT HALOGEN, FRONT, RECTANGULAR
 FEU DE POSITION AVANT ET CLIGNOTANT RECTANGULAIRE HALOGENE
 RICHTUNGS- UND POSITIONSLICHT, VORNE, RECHTECKIG, HALOGEN
 PILOTO DELANTERO DE POSICIÓN E INTERMITENTE HALÓGENO



| Skù | Tensione nominale / Rated voltage | Lato / Side | Dimensioni / Dimensions | Collegamento elettrico / Electrical connection | Note / Notes | Certificazioni / Certifications | Prodotti compatibili / Compatible products |
|--------------|--------------------------------------|---------------|----------------------------|---|---|------------------------------------|---|
| 03944 | 12-24 V | Dx-Sx / Rh-Lh | 182x66x75 mm | passacavo / grommet | Lampadine non incluse / Bulbs not included | ECE | 00397,00441,00524,04019 |

FANALE DIREZIONE-POSIZIONE ALOGENO ANTERIORE RETTANGOLARE

DIRECTION AND POSITION LIGHT HALOGEN, FRONT, RECTANGULAR
 FEU DE POSITION AVANT ET CLIGNOTANT RECTANGULAIRE HALOGENE
 RICHTUNGS- UND POSITIONSLICHT, VORNE, RECHTECKIG, HALOGEN
 PILOTO DELANTERO DE POSICIÓN E INTERMITENTE HALÓGENO RECTANGULAR



1



2

Articoli a ricambio

| | | | |
|--|--------------|---------------------------------|-------------------------|
| | 02808 | Lente a ricambio | |
| | 04525 | Scarpetta posteriore per fanali | 02807,19799,02822,02823 |

| Skù | Pos. | Tensione nominale / Rated voltage | Lato / Side | Dimensioni / Dimensions | Interasse fori / Hole spacing | Collegamento elettrico / Electrical connection | Note / Notes | Certificazioni / Certifications | Prodotti compatibili / Compatible products |
|--------------|------|--------------------------------------|------------------|----------------------------|----------------------------------|---|---|------------------------------------|---|
| 02807 | 1 | 12-24 V | Dx-Sx / Rh-Lh | | 58 mm | passacavo / grommet | Lampadine non incluse / Bulbs not included | ECE | 00397,00441,00524,04019 |
| 19799 | 2 | 12-24 V | Dx-Sx / Rh-Lh | 160x71x70 mm | 58 mm | passacavo / grommet | Lampadine non incluse / Bulbs not included | ECE | 00397,00441,00524,04019 |

FANALE DIREZIONE-POSIZIONE ALOGENO ANTERIORE RETTANGOLARE

DIRECTION AND POSITION LIGHT HALOGEN, FRONT, RECTANGULAR
 FEU DE POSITION AVANT ET CLIGNOTANT RECTANGULAIRE HALOGENE
 RICHTUNGS- UND POSITIONSLICHT, VORNE, RECHTECKIG, HALOGEN
 PILOTO DELANTERO DE POSICIÓN E INTERMITENTE HALÓGENO RECTANGULAR

Articoli a ricambio

| | | | |
|--|--------------|------------------|-------|
| | 04260 | Lente a ricambio | 03826 |
| | 04261 | Lente a ricambio | 03827 |

| Skù | Tensione nominale / Rated voltage | Lato / Side | Dimensioni / Dimensions | Interasse fori / Hole spacing | Collegamento elettrico / Electrical connection | Certificazioni / Certifications | Prodotti compatibili / Compatible products |
|--------------|--------------------------------------|-------------|----------------------------|----------------------------------|---|------------------------------------|---|
| 03826 | 12-24 V | Dx / Rh | 144,2x93x64 mm | 60 mm | passacavo / grommet | ECE | 00397,00441,00524,04019 |
| 03827 | 12-24 V | Sx / Lh | 144,2x93x64 mm | 60 mm | passacavo / grommet | ECE | 00397,00441,00524,04019 |

FANALE DIREZIONE-POSIZIONE ALOGENO ANTERIORE RETTANGOLARE COBO

DIRECTION AND POSITION LIGHT HALOGEN, FRONT, RECTANGULAR COBO
 FEU DE POSITION AVANT ET CLIGNOTANT RECTANGULAIRE HALOGENE COBO
 RICHTUNGS- UND POSITIONSLICHT, VORNE, RECHTECKIG, HALOGEN COBO
 PILOTO DELANTERO DE POSICIÓN E INTERMITENTE HALÓGENO RECTANGULAR COBO

Articoli a ricambio

| | | | |
|--|--------------|------------------|-------|
| | 02868 | Lente a ricambio | 02867 |
|--|--------------|------------------|-------|

| Skù | Brand / Brand | Tensione nominale / Rated voltage | Lato / Side | Dimensioni / Dimensions | Interasse fori / Hole spacing | Collegamento elettrico / Electrical connection | Note / Notes | Certificazioni / Certifications | Prodotti compatibili / Compatible products |
|--------------|------------------|--------------------------------------|-------------|----------------------------|----------------------------------|---|--|------------------------------------|---|
| 02776 | Cobo | 12-24 V | Dx / Rh | 160x102x100 mm | 40 mm | passacavo / grommet | Lampadine non include / Bulbs non included | ECE | 00397,00441,00524, 02858,04019 |
| 02781 | Cobo | 12-24 V | Sx / Lh | 160x102x100 mm | 40 mm | passacavo / grommet | Lampadine non include / Bulbs non included | ECE | 00397,00441,00524, 02858,04019 |

FANALE DIREZIONE-POSIZIONE ALOGENO ANTERIORE RETTANGOLARE

DIRECTION AND POSITION LIGHT HALOGEN, FRONT, RECTANGULAR
 FEU DE POSITION AVANT ET CLIGNOTANT RECTANGULAIRE HALOGENE
 RICHTUNGS- UND POSITIONSLICHT, VORNE, RECHTECKIG, HALOGEN
 PILOTO DELANTERO DE POSICIÓN E INTERMITENTE HALÓGENO RECTANGULAR

Articoli a ricambio

| | | | |
|--|--------------|------------------|-------|
| | 02872 | Lente a ricambio | 02870 |
| | 02873 | Lente a ricambio | 02871 |

| Skù | Tensione nominale / Rated voltage | Lato / Side | Dimensioni / Dimensions | Collegamento elettrico / Electrical connection | Certificazioni / Certifications | Note / Notes | Prodotti compatibili / Compatible products |
|--------------|--------------------------------------|-------------|----------------------------|---|------------------------------------|---|---|
| 02870 | 12-24 V | Dx / Rh | 170x90x61 mm | cavo 20 cm / cable 20 cm | ECE | Lampadine non incluse / Bulbs not included | 00397,00441,00524,04019 |
| 02871 | 12-24 V | Sx / Lh | 170x90x61 mm | cavo 20 cm / cable 20 cm | ECE | Lampadine non incluse / Bulbs not included | 00397,00441,00524,04019 |

FANALE POSTERIORE LED 13,5V QUADRATO

SQUARE LED REAR LIGHT 13,5V
 FEU ARRIÈRE LED CARRÉ 13,5V
 QUADRATISCHE LED-RÜCKLEUCHTE 13,5V
 LUZ TRASERA LED CUADRADA 13,5V



| Skù | Tensione nominale / Rated voltage | Funzioni / Functions | Lato / Side | Dimensioni / Dimensions | Interasse fori / Hole spacing | Collegamento elettrico / Electrical connection | Grado protezione ip / Degree of protection ip | Certificazioni / Certifications |
|--------------|---|--|------------------|----------------------------|----------------------------------|--|--|------------------------------------|
| 75275 | 12 V | Luce di posizione, indicatore di direzione, stop, luce targa, catadiottro / Position light, direction indicator, stop light, license plate light, reflector | Dx/Sx / Rh/Lh | 105,8x35x98 mm | 55 mm | cavo 150 mm / cable 150 mm | IP65 | ECE, CE, Rohs |

FANALE POSTERIORE LED 12-24V QUADRATO

SQUARE LED REAR LIGHT 12-24V
 FEU ARRIÈRE LED CARRÉ 12-24V
 QUADRATISCHE LED-RÜCKLEUCHTE 12-24V
 LUZ TRASERA LED CUADRADA 12-24V



| Skü | Tensione nominale / Rated voltage | Funzioni / Functions | Lato / Side | Dimensioni / Dimensions | Interasse fori / Hole spacing | Collegamento elettrico / Electrical connection | Grado protezione ip / Degree of protection ip | Certificazioni / Certifications |
|--------------|-----------------------------------|---|---------------|-------------------------|-------------------------------|--|---|---------------------------------|
| 67948 | 12-24 V | Luce di posizione, indicatore di direzione, stop, luce targa, catadiottro / Position light, direction indicator, stop light, license plate light, reflector | Dx/Sx / Rh/Lh | 105,5x36,4x97,8 mm | 55 mm | cavo 150 mm / cable 150 mm | IP65 | ECE, CE, Rohs |

FANALE POSTERIORE LED 12-24V QUADRATO

SQUARE LED REAR LIGHT 12-24V
 FEU ARRIÈRE LED CARRÉ 12-24V
 QUADRATISCHE LED-RÜCKLEUCHTE 12-24V
 LUZ TRASERA LED CUADRADA 12-24V



| Skü | Tensione nominale / Rated voltage | Funzioni / Functions | Lato / Side | Dimensioni / Dimensions | Interasse fori / Hole spacing | Collegamento elettrico / Electrical connection | Grado protezione ip / Degree of protection ip | Certificazioni / Certifications |
|----------------|-----------------------------------|---|-------------|-------------------------|-------------------------------|--|---|---------------------------------|
| 0F07287 | 12-24 V | Luce di posizione, indicatore di direzione, luce stop e luce targa / Position light, direction indicator, stop light, license plate light | Sx / Lh | 101x56x121 mm | 45 mm | cavo 200 cm / cable 200 cm | IP66/68 | ECE, EMC, CE, Rohs |
| 0F07288 | 12-24 V | Luce di posizione, indicatore di direzione e stop / Position light, direction indicator and stop light | Dx / Rh | 101x56x121 mm | 45 mm | cavo 200 cm / cable 200 cm | IP66/68 | ECE, EMC, CE, Rohs |

FANALE POSTERIORE LED 12V

LED REAR LIGHT 12V
 FEU ARRIÈRE LED 12V
 LED-RÜCKLEUCHTE 12V
 LUZ TRASERA LED 12V



| Skü | Tensione nominale / Rated voltage | Funzioni / Functions | Lato / Side | Dimensioni / Dimensions | Interasse fori / Hole spacing | Collegamento elettrico / Electrical connection | Grado protezione ip / Degree of protection ip | Certificazioni / Certifications |
|----------------|-----------------------------------|---|-------------|-------------------------|-------------------------------|--|---|---------------------------------|
| 0F07296 | 12 V | Luce di posizione, indicatore di direzione, luce stop e luce targa / Position light, direction indicator, stop light, license plate light | Sx / Lh | 100x30x92,7 mm | 45 mm | cavo 100 cm / cable 100 cm | IP66/68 | ECE, EMC, CE, Rohs |
| 0F07297 | 12 V | Luce di posizione, indicatore di direzione e stop / Position light, direction indicator and stop light | Dx / Rh | 100x30x92,7 mm | 45 mm | cavo 100 cm / cable 100 cm | IP66/68 | ECE, EMC, CE, Rohs |

FANALE POSTERIORE LED 12-24V QUADRATO

SQUARE LED REAR LIGHT 12-24V
 FEU ARRIÈRE LED CARRÉ 12-24V
 QUADRATISCHE LED-RÜCKLEUCHTE 12-24V
 LUZ TRASERA LED CUADRADA 12-24V



| Skü | Tensione nominale / Rated voltage | Funzioni / Functions | Lato / Side | Dimensioni / Dimensions | Interasse fori / Hole spacing | Collegamento elettrico / Electrical connection | Grado protezione ip / Degree of protection ip | Certificazioni / Certifications | Prodotti compatibili / Compatible products |
|-------|-----------------------------------|---|-------------|-------------------------|-------------------------------|---|---|---------------------------------|--|
| 55331 | 12-24 V | Luce di posizione, indicatore di direzione e stop / Rear position light, indicator light, stop light | Dx / Rh | 108x38x102 mm | 45 mm | cavo 200 mm con connettore 4 vie / 200 mm cable with 4-pole connector | IP66/68 | ECE, EMC, CE, Rohs | 55574 |
| 55332 | 12-24 V | Indicatore di direzione, luce stop, luce di posizione e luce targa / Rear position light, indicator light, stop light, number plate light | Sx / Lh | 108x38x102 mm | 45 mm | cavo 200 mm con connettore 4 vie / 200 mm cable with 4-pole connector | IP66/68 | ECE, EMC, CE, Rohs | 55574 |

FANALE POSTERIORE LED 12-24V QUADRATO

SQUARE LED REAR LIGHT 12-24V
 FEU ARRIÈRE LED CARRÉ 12-24V
 QUADRATISCHE LED-RÜCKLEUCHTE 12-24V
 LUZ TRASERA LED CUADRADA 12-24V



1



2



| Skü | Pos. | Tensione nominale / Rated voltage | Funzioni / Functions | Lato / Side | Dimensioni / Dimensions | Interasse fori / Hole spacing | Collegamento elettrico / Electrical connection | Grado protezione ip / Degree of protection ip | Certificazioni / Certifications |
|-------|------|-----------------------------------|--|-------------|-------------------------|-------------------------------|--|---|---------------------------------|
| 67944 | 1 | 12-24 V | Indicatore di direzione, luce stop, luce di posizione e luce targa / Direction indicator, stop light, position light and license plate light | Dx / Rh | 106,5x98,8x35 mm | 55 mm | cavo 150 mm / cable 150 mm | IP65 | ECE, CE, Rohs |
| 67945 | 2 | 12-24 V | Indicatore di direzione, luce stop, luce di posizione e luce targa / Direction indicator, stop light, position light and license plate light | Sx / Lh | 106,5x98,8x35 mm | 55 mm | cavo 150 mm / cable 150 mm | IP65 | ECE, CE, Rohs |

FANALE POSTERIORE LED 12V QUADRATO

SQUARE LED REAR LIGHT 12V
 FEU ARRIÈRE LED CARRÉ 12V
 QUADRATISCHE LED-RÜCKLEUCHTE 12V
 LUZ TRASERA LED CUADRADA 12V

Articoli a ricambio

| | | | |
|--|--------------|---|-------------------|
| | 17673 | Innesto rapido giallo per fanale sinistro | |
| | 17674 | Innesto rapido verde per fanale destro | 84496,55266,84494 |

| Skù | Tensione nominale / Rated voltage | Funzioni / Functions | Lato / Side | Materiale lente / Lens material | Corpo faro / Light body | Dimensioni / Dimensions | Interasse fori / Hole spacing | Grado protezione ip / Degree of protection ip | Collegamento elettrico / Electrical connection | Certificazioni / Certifications |
|--------------|-----------------------------------|--|-------------|---------------------------------|-------------------------|-------------------------|-------------------------------|---|--|---------------------------------|
| 84505 | 12 V | Luce di posizione, indicatore di direzione, stop, luce targa, catadiottero / Position light, direction indicator, stop light, license plate light, reflector | Sx / Lh | PC | ABS | 105,2x42x99,2 mm | 56 mm | IP65 | cavo 250 mm / cable 250 mm | ECE, CE, Rohs |
| 84506 | 12 V | Luce di posizione, indicatore di direzione, stop, catadiottero / Position light, direction indicator, stop light, reflector | Dx / Rh | PC | ABS | 105,2x42x99,2 mm | 56 mm | IP65 | cavo 250 mm / cable 250 mm | ECE, CE, Rohs |

FANALE POSTERIORE LED 12-24V RETTANGOLARE

RECTANGULAR LED REAR LIGHT 12-24V
 FEU ARRIÈRE LED 12-24 V RECTANGULAIRE
 LED-RÜCKLEUCHTE 12-24 V, RECHTECKIG
 LUZ TRASERA LED RECTANGULAR 12-24 V



| Skù | Tensione nominale / Rated voltage | Funzioni / Functions | Lato / Side | Materiale lente / Lens material | Corpo faro / Light body | Dimensioni / Dimensions | Interasse fori / Hole spacing | Collegamento elettrico / Electrical connection | Grado protezione ip / Degree of protection ip | Certificazioni / Certifications |
|--------------|-----------------------------------|--|---------------|---------------------------------|-------------------------|-------------------------|-------------------------------|--|---|---------------------------------|
| 60076 | 12-24 V | Luce di posizione, indicatore di direzione, stop e catadiottero / Position light, direction indicator, stop light, reflector | Dx-Sx / Rh-Lh | PMMA | ABS | 191x31x49,4 mm | 174 mm | cavo 300 mm / cable 300 mm | IP66 | ECE, EMC, CE, RoHS |

FANALE POSTERIORE LED DESTRO E SINISTRO 12-24V

12-24V LED REAR LIGHT, RIGHT-LEFT
 PHARE ARRIÈRE LED 12-24V, DROIT-GAUCHE
 LED-RÜCKLEUCHTE 12-24V, RECHTS-LINKS
 FARO TRASERO LED 12-24V, DERECHO-IZQUIERDO



| Skù | Tensione nominale / Rated voltage | Funzioni / Functions | Lato / Side | Dimensioni / Dimensions | Interasse fori / Hole spacing | Grado protezione ip / Degree of protection ip | Collegamento elettrico / Electrical connection | Certificazioni / Certifications |
|--------------|-----------------------------------|--|---------------|-------------------------|-------------------------------|---|--|---------------------------------|
| 55342 | 12-24 V | Luce di posizione, indicatore di direzione, stop / Position light, direction indicator, stop light | Dx-Sx / Rh-Lh | 200x60x70 mm | 90 mm | IP66/68 | cavo 200 cm / cable 200 cm | ECE, EMC, CE, RoHS |

FANALE POSTERIORE LED 12-30V, DESTRO E SINISTRO

12-30V LED REAR LIGHT, RIGHT AND LEFT
 PHARE ARRIÈRE LED 12-30V, DROIT ET GAUCHE
 12-30V LED-RÜCKLEUCHTE, RECHTS UND LINKS
 FARO TRASERO LED 12-30V, DERECHO E IZQUIERDO



| Skü | Tensione nominale / Rated voltage | Funzioni / Functions | Lato / Side | Dimensioni / Dimensions | Interasse fori / Hole spacing | Grado protezione ip / Degree of protection ip | Collegamento elettrico / Electrical connection | Certificazioni / Certifications |
|-------|-----------------------------------|--|---------------|-------------------------|-------------------------------|---|--|---------------------------------|
| 75255 | 12-24 V | Luce di posizione, stop, indicatore di direzione, catadiottro / Position light, direction indicator, stop light, reflector | Dx-Sx / Rh-Lh | 205x30x95 mm | 150 mm | IP65 | cavo 150 mm / cable 150 mm | ECE, EMC, CE, RoHS |

FANALE POSTERIORE LED 12V, RETTANGOLARE

LED REAR LIGHT 12V, RECTANGULAR
 FEU ARRIÈRE LED 12V RECTANGULAIRE
 LED-RÜCKLEUCHTE 12V RECHTECKIG
 LUZ TRASERA LED 12V, RECTANGULAR



| Skü | Tensione nominale / Rated voltage | Funzioni / Functions | Lato / Side | Dimensioni / Dimensions | Interasse fori / Hole spacing | Grado protezione ip / Degree of protection ip | Collegamento elettrico / Electrical connection | Certificazioni / Certifications |
|-------|-----------------------------------|--|-------------|-------------------------|-------------------------------|---|--|---------------------------------|
| 84678 | 12 V | Luce di posizione, indicatore di direzione, stop, catadiottro / Position light, direction indicator, stop light, reflector | Dx / Rh | 150x22x80 mm | 100 mm | IP65 | cavo 35 cm / cable 35 cm | ECE, EMC, CE, RoHS |
| 84679 | 12 V | Luce di posizione, indicatore di direzione, stop, catadiottro / Position light, direction indicator, stop light, reflector | Sx / Lh | 150x22x80 mm | 100 mm | IP65 | cavo 35 cm / cable 35 cm | ECE, EMC, CE, RoHS |

FANALE POSTERIORE LED 12-24V DIAMETRO 140 MM

LED REAR LIGHT 12-24V, 140 MM DIAMETER
 FEU ARRIÈRE LED 12-24V, DIAMÈTRE 140 MM
 LED-RÜCKLEUCHTE 12-24V, DURCHMESSER 140 MM
 LUZ TRASERA LED 12-24V, DIÁMETRO 140 MM



| Skü | Tipo luce / Light type | Tensione nominale / Rated voltage | Funzioni / Functions | Lato / Side | Diámetro / Diameter | Interasse fori / Hole spacing | Grado protezione ip / Degree of protection ip | Collegamento elettrico / Electrical connection | Certificazioni / Certifications |
|-------|------------------------|-----------------------------------|---|---------------|---------------------|-------------------------------|---|--|---------------------------------|
| 76442 | LED | 12-24 V | Luce di posizione, indicatore di direzione e stop / Position light, direction indicator, stop light | Dx/Sx / Rh/Lh | 140 mm | 45 mm | IP65 | faston 6,3 mm / 6.3 mm faston connector | ECE, CE, Rohs |

FANALE POSTERIORE LED DESTRO E SINISTRO 12-24V DIAMETRO 148 MM

12-24V LED REAR LIGHT, RIGHT AND LEFT, DIAMETER 148 MM
 PHARE ARRIÈRE LED 12-24V, DROIT ET GAUCHE, DIAMÈTRE 148 MM
 12-24V LED-RÜCKLEUCHTE, RECHTS UND LINKS, DURCHMESSER 148 MM
 FARO TRASERO LED 12-24V, DERECHO E IZQUIERDO, DIÁMETRO 148 MM

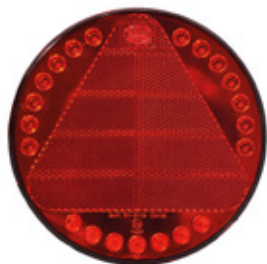

| Skü | Tensione nominale / Rated voltage | Funzioni / Functions | Lato / Side | Dimensioni / Dimensions | Interasse fori / Hole spacing | Grado protezione ip / Degree of protection ip | Collegamento elettrico / Electrical connection | Certificazioni / Certifications |
|--------------|-----------------------------------|--|---------------|-------------------------|-------------------------------|---|--|---------------------------------|
| 55322 | 12-24 V | Luce di posizione, stop, indicatore di direzione, catadiottro / Position light, direction indicator, stop light, reflector | Dx-Sx / Rh-Lh | 148x16 mm | 45 mm | IP65 | cavo 200 mm / cable 200 mm | ECE, EMC, CE, RoHS |

FANALE POSTERIORE LED DESTRO E SINISTRO 12-24V DIAMETRO 140 MM

12-24V LED REAR LIGHT, RIGHT AND LEFT, DIAMETER 140 MM
 PHARE ARRIÈRE LED 12-24V, DROIT ET GAUCHE, DIAMÈTRE 140 MM
 12-24V LED-RÜCKLEUCHTE, RECHTS UND LINKS, DURCHMESSER 140 MM
 FARO TRASERO LED 12-24V, DERECHO E IZQUIERDO, DIÁMETRO 140 MM



| Skü | Tensione nominale / Rated voltage | Funzioni / Functions | Lato / Side | Dimensioni / Dimensions | Interasse fori / Hole spacing | Grado protezione ip / Degree of protection ip | Collegamento elettrico / Electrical connection | Certificazioni / Certifications |
|--------------|-----------------------------------|--|---------------|-------------------------|-------------------------------|---|--|---------------------------------|
| 67943 | 12-24 V | Luce di posizione, indicatore di direzione, stop / Position light, direction indicator, stop light | Dx-Sx / Rh-Lh | 140x41 mm | 55 mm | IP65 | cavo 20 cm / cable 20 cm | ECE, EMC, CE, RoHS |

FANALE POSTERIORE LED LATO 12-24V TRIANGOLARE 163X38,8X144 MM

LED REAR LIGHT 12-24V, 140 MM DIAMETER
 FEU ARRIÈRE LED 12-24V, DIAMÈTRE 140 MM
 LED-RÜCKLEUCHTE 12-24V, DURCHMESSER 140 MM
 LUZ TRASERA LED 12-24V, DIÁMETRO 140 MM



| Skü | Tensione nominale / Rated voltage | Funzioni / Functions | Lato / Side | Dimensioni / Dimensions | Interasse fori / Hole spacing | Collegamento elettrico / Electrical connection | Grado protezione ip / Degree of protection ip | Certificazioni / Certifications |
|--------------|-----------------------------------|---|-------------|-------------------------|-------------------------------|--|---|---------------------------------|
| 55961 | 12-24 V | Luce di posizione, stop, indicatore di direzione, catadiottro / Tail light, stop light, turn indicator light, reflector | Dx / Rh | 163x38,8x144 mm | 63,5 mm | cavo 185 cm / cable 185 cm | IP66/68 | ECE, EMC, CE, Rohs / CE |
| 55962 | 12-24 V | Luce di posizione, stop, indicatore di direzione, catadiottro / Tail light, stop light, turn indicator light, reflector | Sx / Lh | 163x38,8x144 mm | 63,5 mm | cavo 185 cm / cable 185 cm | IP66/68 | ECE, EMC, CE, Rohs / CE |

FANALI POSTERIORI LED RETTANGOLARI CON FRECCIA DINAMICA

RECTANGULAR LED REAR LIGHTS WITH DYNAMIC INDICATOR
 PHARES ARRIÈRE LED RECTANGULAIRES AVEC CLIGNOTANT DYNAMIQUE
 RECHTECKIGE LED-RÜCKLEUCHTEN MIT DYNAMISCHEM BLINKER
 FAROS TRASEROS LED RECTANGULARES CON INTERMITENTE DINÁMICO



1



2

| SKU | Pos. | Tensione nominale / Rated voltage | Funzioni / Functions | Lato / Side | Dimensioni / Dimensions | Interasse fori / Hole spacing | Grado protezione ip / Degree of protection ip | Collegamento elettrico / Electrical connection | Certificazioni / Certifications | Prodotti compatibili / Compatible products |
|-------|------|-----------------------------------|---|---------------|-------------------------|-------------------------------|---|--|---------------------------------|--|
| 65948 | 1 | 12 V | Luce di posizione, freccia dinamica, stop, luce targa, retromarcia, retronebbia, catadiottro / Position light, dynamic indicator, stop light, license plate light, reverse light, rear fog light, reflector | Dx-Sx / Rh-Lh | 200,5x28,9x85,3 mm | 100 mm | IP66/68 | connettore con cavo 100 mm / connector with cable 100 mm | ECE, EMC, CE, RoHS | 37889 |
| 65949 | 2 | 12-24 V | Luce di posizione, freccia dinamica, stop, luce targa, retromarcia, retronebbia, catadiottro / Position light, dynamic indicator, stop light, license plate light, reverse light, rear fog light, reflector | Dx-Sx / Rh-Lh | 235,6x40,4x103,6 mm | 150 mm | IP66/68 | cavo 150 mm / cable 150 mm | ECE, EMC, CE, RoHS | |

FANALE POSTERIORE LED 12V CON CONNETTORE

LED REAR LIGHT 12V WITH CONNECTOR
 FEU ARRIÈRE LED 12V AVEC CONNECTEUR
 LED-RÜCKLEUCHTE 12V MIT STECKER
 PILOTO TRASERO LED 12V CON CONECTOR



Articoli a ricambio

| | | | |
|--|--------------|---|-------------------|
| | 17673 | Innesto rapido giallo per fanale sinistro | 84497,55267,84495 |
| | 17674 | Innesto rapido verde per fanale destro | 84496,55266,84494 |

| SKU | Tensione nominale / Rated voltage | Funzioni / Functions | Lato / Side | Dimensioni / Dimensions | Interasse fori / Hole spacing | Grado protezione ip / Degree of protection ip | Collegamento elettrico / Electrical connection | Certificazioni / Certifications |
|-------|-----------------------------------|--|-------------|-------------------------|-------------------------------|---|--|---------------------------------|
| 84496 | 12 V | Luce di posizione, indicatore di direzione, luce stop, luce targa, retromarcia, catadiottro / Position light, direction indicator, stop light, license plate light, reverse light, reflector | Dx / Rh | 227,6x55x105,8 mm | 151 mm | IP65 | connettore con cavo 20 cm / connector with 20 cm cable | ECE, EMC, CE, RoHS |
| 84497 | 12 V | Luce di posizione, indicatore di direzione, luce stop, luce targa, retromarcia, catadiottro / Position light, direction indicator, stop light, license plate light, reverse light, reflector | Sx / Lh | 227,6x55x105,8 mm | 151 mm | IP65 | connettore con cavo 20 cm / connector with 20 cm cable | ECE, EMC, CE, RoHS |

FANALE POSTERIORE LED 12-24V

LED REAR LIGHT 12-24V WITH CONNECTOR
 FEU ARRIÈRE LED 12-24V
 LED-RÜCKLEUCHTE 12-24V
 LUZ TRASERA LED 12-24V CON CONECTOR

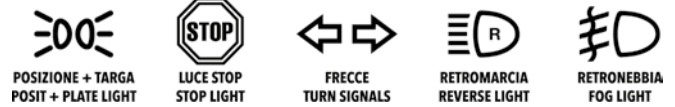

| Skü | Funzioni / Functions | Lato / Side | Collegamento elettrico / Electrical connection | Dimensioni / Dimensions | Interasse fori / Hole spacing | Grado protezione ip / Degree of protection ip |
|--------------|--|-------------|--|-------------------------|-------------------------------|---|
| 57345 | Luce di posizione, luce stop, retromarcia, retronebbia, indicatore di direzione, catarifrangente triangolare / Position light, stop light, reverse light, fog light, turn signal, triangular reflector | Dx / Rh | cavo 200 cm / cable 200 cm | 242x58,2x134 mm | 150 mm | IP68 |
| 57346 | Luce di posizione, luce stop, retromarcia, retronebbia, indicatore di direzione, catarifrangente triangolare / Position light, stop light, reverse light, fog light, turn signal, triangular reflector | Sx / Lh | cavo 200 cm / cable 200 cm | 242x58,2x134 mm | 150 mm | IP68 |

FANALE POSTERIORE LED 12-36V CON CONNETTORE

LED REAR LIGHT 12-36V WITH CONNECTOR
 FEU ARRIÈRE LED 12-36V AVEC CONNECTEUR
 LED-RÜCKLEUCHTE 12-36V MIT STECKER
 LUZ TRASERA LED 12-36V CON CONECTOR

Articoli a ricambio

| | | | |
|--|--------------|---|-------------------|
| | 17673 | Innesto rapido giallo per fanale sinistro | 84497,55267,84495 |
| | 17674 | Innesto rapido verde per fanale destro | 84496,55266,84494 |

| Skü | Tipo luce / Light type | Tensione nominale / Rated voltage | Funzioni / Functions | Lato / Side | Dimensioni / Dimensions | Interasse fori / Hole spacing | Collegamento elettrico / Electrical connection | Grado protezione ip / Degree of protection ip | Certificazioni / Certifications |
|--------------|------------------------|-----------------------------------|---|-------------|-------------------------|-------------------------------|--|---|---------------------------------|
| 55266 | LED | 12-24V | Posizione, indicatore di direzione, stop, fendinebbia, catadiottro / Position light, direction indicator, stop light, reverse light, reflector | Dx / Rh | 240x55x140 mm | 152 mm | connettore / connector | IP66 | ECE, EMC, CE, Rohs |
| 55267 | LED | 12-24 V | Posizione, indicatore di direzione, stop, retromarcia, catadiottro / Position light, direction indicator, stop light, rear fog light, reflector | Sx / Lh | 240x55x140 mm | 152 mm | connettore / connector | IP66 | ECE, EMC, CE, Rohs |

FANALE POSTERIORE LED 12-24V

LED REAR LIGHT 12-24V WITH CONNECTOR
 FEU ARRIÈRE À LED 12-24V AVEC CONNECTEUR
 LED-RÜCKLEUCHTE 12-24V MIT STECKER
 LUZ TRASERA LED 12-24V



1

2

3

| SKU | Pos. | Funzioni / Functions | Lato / Side | Collegamento elettrico / Electrical connection | Interasse fori / Hole spacing | Grado protezione ip / Degree of protection ip | Dimensioni / Dimensions |
|-------|------|--|-------------|--|-------------------------------|---|-------------------------|
| 77011 | 1-2 | Luce di posizione, indicatore di direzione, stop, luce targa, retronebbia, retromarcia, catadiottro triangolare / Position light, direction indicator, stop light, license plate light, fog light, reverse light, triangular reflector | Sx / Lh | 2 connettori 13 poli con cavo 300 cm / 2 pcs 13-pin connectors with 300 cm cable | 190 mm | IP66 | 245x40x151 mm |
| 77012 | 1-3 | Luce di posizione, indicatore di direzione, stop, luce targa, retronebbia, retromarcia, catadiottro triangolare / Position light, direction indicator, stop light, license plate light, fog light, reverse light, triangular reflector | Dx / Rh | 2 connettori 13 poli con cavo 300 cm / 2 13-pin connectors with 300 cm cable | 190 mm | IP66 | 245x40x151 mm |

FANALE POSTERIORE LED 12V

LED REAR LIGHT 12V
 FEU ARRIÈRE LED 12V
 LED-RÜCKLEUCHTE 12V
 LUZ TRASERA LED 12V



Articoli a ricambio

| | | | |
|--|--------------|---|-------------------|
| | 17673 | Innesto rapido giallo per fanale sinistro | 84497,55267,84495 |
| | 17674 | Innesto rapido verde per fanale destro | 84496,55266,84494 |

| SKU | Tensione nominale / Rated voltage | Funzioni / Functions | Lato / Side | Dimensioni / Dimensions | Interasse fori / Hole spacing | Grado protezione ip / Degree of protection ip | Collegamento elettrico / Electrical connection | Certificazioni / Certifications |
|-------|-----------------------------------|---|-------------|-------------------------|-------------------------------|---|--|---------------------------------|
| 84494 | 12 V | Luce di posizione, indicatore di direzione, segnale di stop, luce targa, retromarcia, fendinebbia, catadiottro / Position light, direction indicator, stop light, license plate light, reverse light, rear fog light, reflector | Dx / Rh | 243,6x48x148,5 mm | 152,4 mm | IP65 | connettore con cavo 20 cm / connector with 20 cm cable | ECE, EMC, CE, RoHS |
| 84495 | 12 V | Luce di posizione, indicatore di direzione, segnale di stop, luce targa, retromarcia, fendinebbia, catadiottro / Position light, direction indicator, stop light, license plate light, reverse light, rear fog light, reflector | Sx / Lh | 243,6x48x148,5 mm | 152,4 mm | IP65 | connettore con cavo 20 cm / connector with 20 cm cable | ECE, EMC, CE, RoHS |

FANALE POSTERIORE ALOGENO DX/SX RETTANGOLARE

HALOGEN REAR LIGHT RH/LH RECTANGULAR
 FEU ARRIÈRE HALOGENÈ DROIT/GAUCHE RECTANGULAIRE
 RECHTE/LINKE RECHTECKIGE HALOGEN-RÜCKLEUCHTE
 PILOTO TRASERO HALÓGENO DERECHO/IZQUIERDO RECTANGULAR

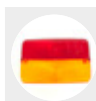

Articoli a ricambio

02951 Lente a ricambio posteriore

| Skù | Brand / Brand | Tensione nominale / Rated voltage | Dimensioni / Dimensions | Interasse fori / Hole spacing | Collegamento elettrico / Electrical connection | Certificazioni / Certifications | Note / Notes | Prodotti compatibili / Compatible products |
|--------------|---------------|-----------------------------------|-------------------------|-------------------------------|--|---------------------------------|--|--|
| 02950 | Cobo | 12-24 V | 120x56x80 mm | 58 mm | passacavo / grommet | ECE, CE | Lampadine non incluse / Bulbs not included | 00440,00441,00501,04019 |

FANALE POSTERIORE ALOGENO QUADRATO

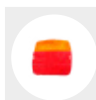
HALOGEN REAR LIGHT SQUARE
 FEU ARRIÈRE HALOGENÈ CARRÉ
 QUADRATISCHE HALOGEN-RÜCKLICHT RECHTECKIG
 PILOTO TRASERO HALÓGENO, CUADRADO

Articoli a ricambio

02815 Lente a ricambio

| Skù | Tensione nominale / Rated voltage | Funzioni / Functions | Lato / Side | Collegamento elettrico / Electrical connection | Dimensioni / Dimensions | Interasse fori / Hole spacing | Certificazioni / Certifications | Omologazioni / Homologations | Prodotti compatibili / Compatible products | Note / Notes |
|--------------|-----------------------------------|---|-------------|--|-------------------------|-------------------------------|---------------------------------|------------------------------|--|--|
| 02813 | 12-24 V | Luce di posizione, indicatore di direzione, stop / Position light, direction indicator, stop light | Dx / Rh | passacavo Ø 4 mm / Ø 4 mm grommet | 107x53x100 mm | 55 mm | ECE, CE | ECE | 00277,00441,00526,04019 | Lampadine non incluse / Bulbs not included |
| 02814 | 12-24 V | Luce di posizione, indicatore di direzione, stop, luce targa / Position light, direction indicator, stop light, license plate light | Sx / Lh | passacavo Ø 4 mm / Ø 4 mm grommet | 107x53x100 mm | 55 mm | ECE, CE | ECE | 00277,00441,00526,04019 | Lampadine non incluse / Bulbs not included |

FANALE POSTERIORE ALOGENO QUADRATO

HALOGEN REAR LIGHT SQUARE
 FEU ARRIÈRE HALOGÈNE CARRÉ
 QUADRATISCHE HALOGEN-RÜCKLICHT RECHTECKIG
 PILOTO TRASERO HALÓGENO, CUADRADO



Articoli a ricambio

 **39094** Lente a ricambio

| Skù | Tensione nominale / Rated voltage | Funzioni / Functions | Lato / Side | Collegamento elettrico / Electrical connection | Dimensioni / Dimensions | Interasse fori / Hole spacing | Certificazioni / Certifications | Prodotti compatibili / Compatible products | Omologazioni / Homologations | Note / Notes |
|-------|-----------------------------------|--|---------------|--|-------------------------|-------------------------------|---------------------------------|--|------------------------------|--|
| 56016 | 12-24 V | Luce di posizione, indicatore di direzione, stop / Position light, direction indicator, stop light | Dx-Sx / Rh-Lh | passacavo / grommet | 100x50x95 mm | 55 mm | ECE, CE | 00440,00441, 00501,04019 | ECE | Lampadine non incluse / Bulbs not included |

FANALI POSTERIORI ALOGENI QUADRATI

SQUARE HALOGEN REAR LIGHTS
 PHARES ARRIÈRE HALOGÈNES CARRÉS
 QUADRATISCHE HALOGEN-RÜCKLEUCHTEN
 FAROS TRASEROS HALÓGENOS CUADRADOS



| Skù | Tipo luce / Light type | Tensione nominale / Rated voltage | Funzioni / Functions | Lato / Side | Collegamento elettrico / Electrical connection | Dimensioni / Dimensions | Interasse fori / Hole spacing | Prodotti compatibili / Compatible products | Certificazioni / Certifications | Omologazioni / Homologations | Note / Notes |
|-------|------------------------|-----------------------------------|--|-------------|--|-------------------------|-------------------------------|--|---------------------------------|------------------------------|--|
| 55368 | Alogeno / Halogen | 12-24 V | Luce di posizione, indicatore di direzione, luce stop / Position light, direction indicator, stop light | Dx / Rh | foro passacavo / cable entry hole | 100x50x95 mm | 55 mm | 00440,00441, 00501,04019 | ECE, CE, RoHS | ECE | Lampadine non incluse / Bulbs not included |
| 55369 | Alogeno / Halogen | 12-24 V | Luce di posizione, indicatore di direzione, luce stop, luce targa / Position light, direction indicator, stop light, license plate light | Sx / Lh | foro passacavo / cable entry hole | 100x50x95 mm | 55 mm | 00440,00441, 00501,04019 | ECE, CE, RoHS | ECE | Lampadine non incluse / Bulbs not included |

FANALE POSTERIORE ALOGENO QUADRATO

HALOGEN REAR LIGHT SQUARE
 FEU ARRIÈRE HALOGÈNE CARRÉ
 QUADRATISCHE HALOGEN-RÜCKLICHT RECHTECKIG
 PILOTO TRASERO HALÓGENO, CUADRADO

Articoli a ricambio

| | | |
|--|--------------|--|
| | 76449 | Lente a ricambio posteriore per art. 76433 e 76434 |
|--|--------------|--|

| Skü | Tensione nominale / Rated voltage | Funzioni / Functions | Lato / Side | Dimensioni / Dimensions | Interasse fori / Hole spacing | Collegamento elettrico / Electrical connection | Certificazioni / Certifications | Prodotti compatibili / Compatible products | Omologazioni / Homologations | Note / Notes |
|--------------|-----------------------------------|--|-------------|-------------------------|-------------------------------|--|---------------------------------|--|------------------------------|--|
| 76433 | 12-24 V | Luce di posizione, indicatore di direzione, stop / Position light, direction indicator, stop light | Dx / Rh | 105x50x97 mm | 55 mm | passacavo / grommet | ECE, CE | 00440,00441, 00501,04019 | ECE | Lampadine non incluse / Bulbs not included |
| 76434 | 12-24 V | Luce di posizione, indicatore di direzione, luce stop, luce targa / Position light, direction indicator, stop light, license plate light | Sx / Lh | 105x50x97 mm | 55 mm | passacavo / grommet | ECE, CE | 00440,00441, 00501,04019 | ECE | Lampadine non incluse / Bulbs not included |

FANALE POSTERIORE ALOGENO QUADRATO

HALOGEN REAR LIGHT SQUARE
 FEU ARRIÈRE HALOGÈNE CARRÉ
 QUADRATISCHE HALOGEN-RÜCKLICHT RECHTECKIG
 PILOTO TRASERO HALÓGENO, CUADRADO

Articoli a ricambio

| | | | |
|--|--------------|------------------|-------|
| | 84503 | Lente a ricambio | 84500 |
| | 84504 | Lente a ricambio | 84501 |

| Skü | Tensione nominale / Rated voltage | Funzioni / Functions | Lato / Side | Dimensioni / Dimensions | Interasse fori / Hole spacing | Certificazioni / Certifications | Note / Notes | Prodotti compatibili / Compatible products |
|--------------|-----------------------------------|---|-------------|-------------------------|-------------------------------|---------------------------------|--|--|
| 84500 | 12-24 V | Luce di posizione, indicatore di direzione, stop / Position light, direction indicator, stop light | Dx / Rh | 110x51x100 mm | 55 mm | ECE, CE | Lampadine non incluse / Bulbs not included | 00397,00441,00524,04019 |
| 84501 | 12-24 V | Luce di posizione, indicatore di direzione, stop, luce targa / Position light, direction indicator, stop light, license plate light | Sx / Lh | 110x51x100 mm | 55 mm | ECE, CE | Lampadine non incluse / Bulbs not included | 00397,00441,00524,04019 |

FANALE POSTERIORE ALOGENO QUADRATO

HALOGEN REAR LIGHT SQUARE
 FEU ARRIÈRE HALOGÈNE CARRÉ
 QUADRATISCHE HALOGEN-RÜCKLICHT RECHTECKIG
 PILOTO TRASERO HALÓGENO, CUADRADO



Articoli a ricambio

| | | | |
|--|--------------|------------------|-------|
| | 02838 | Lente a ricambio | 02836 |
|--|--------------|------------------|-------|

| Skù | Tensione nominale / Rated voltage | Funzioni / Functions | Lato / Side | Dimensioni / Dimensions | Interasse fori / Hole spacing | Certificazioni / Certifications | Note / Notes | Prodotti compatibili / Compatible products |
|--------------|-----------------------------------|---|-------------|-------------------------|-------------------------------|---------------------------------|--|--|
| 02836 | 12-24 V | Luca di posizione, indicatore di direzione, luce stop / Position light, direction indicator, stop light | Dx / Rh | 188x140x140 mm | 170x143 mm | ECE, CE | Lampadine non incluse / Bulbs not included | 00397,00441,00524,04019 |
| 02837 | 12-24 V | Luca di posizione, indicatore di direzione, stop, luce targa / Position light, direction indicator, stop light, license plate light | Sx / Lh | 188x140x140 mm | 170x143 mm | ECE, CE | Lampadine non incluse / Bulbs not included | 00397,00441,00524,04019 |

FANALE POSTERIORE ALOGENO RETTANGOLARE

HALOGEN REAR LIGHT RECTANGULAR
 FEU ARRIÈRE HALOGÈNE RECTANGULAIRE
 HALOGEN-RÜCKLICHT RECHTECKIG
 PILOTO TRASERO HALÓGENO, RECTANGULAR



| Skù | Funzioni / Functions | Tensione nominale / Rated voltage | Dimensioni / Dimensions | Interasse fori / Hole spacing | Lato / Side | Collegamento elettrico / Electrical connection | Note / Notes | Certificazioni / Certifications | Prodotti compatibili / Compatible products | Omologazioni / Homologations |
|--------------|--|-----------------------------------|-------------------------|-------------------------------|---------------|--|--|---------------------------------|--|------------------------------|
| 03976 | Luca di posizione, indicatore di direzione, stop / Position light, direction indicator, stop light | 12-24 V | 184x67x79 mm | 51 mm | Dx-Sx / Rh-Lh | passacavo / grommet | lampadine non incluse / bulbs not included | ECE, CE | 00440,00441,00501,04019 | ECE |

FANALE POSTERIORE ALOGENO RETTANGOLARE

HALOGEN REAR LIGHT RECTANGULAR
 FEU ARRIÈRE HALOGÈNE RECTANGULAIRE
 HALOGEN-RÜCKLICHT RECHTECKIG
 PILOTO TRASERO HALÓGENO, RECTANGULAR

Articoli a ricambio

02856 Lente a ricambio

| Skù | Tipo luce / Light type | Funzioni / Functions | Lato / Side | Collegamento elettrico / Electrical connection | Tipo lampadina / Bulb type | Prodotti compatibili / Compatible products |
|--------------|------------------------|---|---------------|--|----------------------------|--|
| 06112 | Alogeno / Halogen | Luce di posizione, indicatore di direzione, stop, catadiottero / Position light, direction indicator, stop light, reflector | Dx-Sx / Rh-Lh | passacavo / grommet | P21/5W, P21W non incluse | 00440,00441,00501,04019 |

FANALE POSTERIORE ALOGENO RETTANGOLARE

HALOGEN REAR LIGHT RECTANGULAR
 FEU ARRIÈRE HALOGÈNE RECTANGULAIRE
 HALOGEN-RÜCKLICHT RECHTECKIG
 PILOTO TRASERO HALÓGENO, RECTANGULAR



1



2



3



4

Articoli a ricambio

02819 Lente a ricambio

02817



02820 Lente a ricambio

02818



04525 Scarpetta posteriore per fanali

02807,19799,02822,02823



| Skù | Pos. | Tensione nominale / Rated voltage | Dimensioni / Dimensions | Interasse fori / Hole spacing | Funzioni / Functions | Lato / Side | Collegamento elettrico / Electrical connection | Omologazioni / Homologations | Certificazioni / Certifications | Note / Notes | Prodotti compatibili / Compatible products |
|--------------|------|-----------------------------------|-------------------------|-------------------------------|---|-------------|--|------------------------------|---------------------------------|--|--|
| 02817 | 1 | 12-24 V | 160x71x70 mm | 58 mm | Luce di posizione, indicatore di direzione, stop / Position light, direction indicator, stop light | Dx / Rh | passacavo / grommet | ECE | ECE, CE | Lampadine non incluse / Bulbs not included | 00440,00441,00501,04019 |
| 02818 | 2 | 12-24 V | 160x71x70 mm | 58 mm | Luce di posizione, indicatore di direzione, stop, luce targa / Position light, direction indicator, stop light, license plate light | Sx / Lh | passacavo / grommet | ECE | ECE, CE | Lampadine non incluse / Bulbs not included | 00440,00441,00501,04019 |
| 02822 | 3 | 12-24 V | 160x136x85 mm | vedi disegno | Luce di posizione, indicatore di direzione, stop / Position light, direction indicator, stop light | Dx / Rh | passacavo / grommet | ECE | ECE, CE | Lampadine non incluse / Bulbs not included | 00440,00441,00501,04019 |
| 02823 | 4 | 12-24 V | 160x136x85 mm | vedi disegno | Luce di posizione, indicatore di direzione, stop, luce targa / Position light, direction indicator, stop light, license plate light | Sx / Lh | passacavo / grommet | ECE | ECE, CE | Lampadine non incluse / Bulbs not included | 00440,00441,00501,04019 |

FANALE POSTERIORE ALOGENO RETTANGOLARE

HALOGEN REAR LIGHT RECTANGULAR
 FEU ARRIÈRE HALOGÈNE RECTANGULAIRE
 HALOGEN-RÜCKLICHT RECHTECKIG
 PILOTO TRASERO HALÓGENO, RECTANGULAR



Articoli a ricambio



02856 Lente a ricambio

| Skü | Brand / Brand | Tensione nominale / Rated voltage | Dimensioni / Dimensions | Interasse fori / Hole spacing | Funzioni / Functions | Lato / Side | Collegamento elettrico / Electrical connection | Omologazioni / Homologations | Certificazioni / Certifications | Note / Notes | Prodotti compatibili / Compatible products |
|-------|---------------|-----------------------------------|-------------------------|-------------------------------|--|-------------|--|------------------------------|---------------------------------|--|--|
| 02851 | Cobo | 12-24 V | 148x102x100 mm | 41 mm | Luce di posizione, indicatore di direzione, stop, catadiottro / Position light, direction indicator, stop light, reflector | Dx / Rh | passacavo / grommet | ECE | ECE, CE | lampadine non incluse / bulbs not included | 00440,00441,00501,04019 |
| 02852 | Cobo | 12-24 V | 148x102x100 mm | 41 mm | Luce di posizione, indicatore di direzione, stop, catadiottro / Position light, direction indicator, stop light, reflector | Sx / Lh | passacavo / grommet | ECE | ECE, CE | lampadine non incluse / bulbs not included | 00440,00441,00501,04019 |

FANALE POSTERIORE ALOGENO RETTANGOLARE

HALOGEN REAR LIGHT RECTANGULAR
 FEU ARRIÈRE HALOGÈNE RECTANGULAIRE
 HALOGEN-RÜCKLICHT RECHTECKIG
 PILOTO TRASERO HALÓGENO, RECTANGULAR



Articoli a ricambio





02955 Lente a ricambio

| Skü | Funzioni / Functions | Tensione nominale / Rated voltage | Dimensioni / Dimensions | Interasse fori / Hole spacing | Lato / Side | Collegamento elettrico / Electrical connection | Certificazioni / Certifications | Note / Notes | Prodotti compatibili / Compatible products |
|-------|--|-----------------------------------|-------------------------|-------------------------------|-------------|--|---------------------------------|--|--|
| 02953 | Luce di posizione, indicatore di direzione, stop, catadiottro / Position light, direction indicator, stop light, reflector | 12-24 V | 184x67x79 mm | 51 mm | Dx / Rh | passacavo / grommet | ECE, CE | lampadine non incluse / bulbs not included | 00440,00441,00501,04019 |
| 02954 | Luce di posizione, indicatore di direzione, stop, catadiottro / Position light, direction indicator, stop light, reflector | 12-24 V | 184x67x79 mm | 51 mm | Sx / Lh | passacavo / grommet | ECE, CE | lampadine non incluse / bulbs not included | 00440,00441,00501,04019 |

FANALE POSTERIORE ALOGENO

HALOGEN REAR LIGHT
FEU ARRIÈRE HALOGÈNE
HALOGEN-RÜCKLICHT
PILOTO TRASERO HALÓGENO

Articoli a ricambio

| | | | |
|---|--------------|------------------|-------|
|  | 59197 | Lente a ricambio | 12014 |
|  | 59198 | Lente a ricambio | 12015 |

| Skù | Funzioni / Functions | Tensione nominale / Rated voltage | Dimensioni / Dimensions | Interasse fori / Hole spacing | Lato / Side | Collegamento elettrico / Electrical connection | Note / Notes | Certificazioni / Certifications | Prodotti compatibili / Compatible products |
|--------------|--|-----------------------------------|-------------------------|-------------------------------|-------------|--|--|---------------------------------|--|
| 12014 | Luce di posizione, indicatore di direzione, stop / Position light, direction indicator, stop light | 12-24 V | 146,2x93x64 mm | 60 mm | Sx / Lh | passacavo / grommet | lampadine non incluse / bulbs not included | ECE, CE | 00440,00441, 00501,04019 |
| 12015 | Luce di posizione, indicatore di direzione, stop / Position light, direction indicator, stop light | 12-24 V | 146,2x93x64 mm | 60 mm | Dx / Rh | passacavo / grommet | lampadine non incluse / bulbs not included | ECE, CE | 00440,00441, 00501,04019 |

FANALE POSTERIORE ALOGENO RETTANGOLARE

HALOGEN REAR LIGHT RECTANGULAR
FEU ARRIÈRE HALOGÈNE RECTANGULAIRE
HALOGEN-RÜCKLICHT RECHTECKIG
PILOTO TRASERO HALÓGENO, RECTANGULAR

Articoli a ricambio

| | | | |
|---|--------------|---|--|
|  | 22029 | Lente a ricambio posteriore per art. 22023 e art. 22025 | |
|---|--------------|---|--|

| Skù | Funzioni / Functions | Tensione nominale / Rated voltage | Dimensioni / Dimensions | Interasse fori / Hole spacing | Lato / Side | Collegamento elettrico / Electrical connection | Note / Notes | Certificazioni / Certifications | Prodotti compatibili / Compatible products |
|--------------|--|-----------------------------------|-------------------------|-------------------------------|-------------|--|--|---------------------------------|--|
| 22023 | Luce di posizione, indicatore di direzione, stop / Position light, direction indicator, stop light | 12-24 V | 160x147x85 mm | 112,5 mm | Dx / Rh | passacavo / grommet | lampadine non incluse / bulbs not included | ECE, CE | 00440,00441,00501,04019 |
| 22025 | Luce di posizione, indicatore di direzione, stop / Position light, direction indicator, stop light | 12-24 V | 160x147x85 mm | 112,5 mm | Sx / Lh | passacavo / grommet | lampadine non incluse / bulbs not included | ECE, CE | 00440,00441,00501,04019 |

FANALE POSTERIORE ALOGENO RETTANGOLARE

HALOGEN REAR LIGHT RECTANGULAR
 FEUX ARRIÈRE HALOGÈNE RECTANGULAIRE
 HALOGEN-RÜCKLICHT RECHTECKIG
 PILOTO TRASERO HALÓGENO, RECTANGULAR



Articoli a ricambio

| | | | |
|--|--------------|------------------|-------|
| | 59195 | Lente a ricambio | 37337 |
| | 59196 | Lente a ricambio | 36572 |



| Skù | Brand / Brand | Tensione nominale / Rated voltage | Dimensioni / Dimensions | Interasse fori / Hole spacing | Funzioni / Functions | Lato / Side | Collegamento elettrico / Electrical connection | Note / Notes | Certificazioni / Certifications | Prodotti compatibili / Compatible products | Omologazioni / Homologations |
|--------------|---------------|-----------------------------------|-------------------------|-------------------------------|---|-------------|--|--|---------------------------------|--|------------------------------|
| 36572 | Hella | 12-24 V | 158x51x64 mm | 45/98 mm | Luce di posizione, indicatore di direzione, stop, luce targa / Position light, direction indicator, stop light, license plate light | Sx / Lh | passacavo / grommet | lampadine non incluse / bulbs not included | ECE, CE | 00441,00524, 03874,04019 | ECE |
| 37337 | Hella | 12-24 V | 158x51x64 mm | 45/98 mm | Luce di posizione, indicatore di direzione, stop / Position light, direction indicator, stop light | Dx / Rh | passacavo / grommet | lampadine non incluse / bulbs not included | ECE, CE | 00441,00524, 03874,04019 | ECE |

FANALI POSTERIORI ALOGENI ROTONDI

ROUND HALOGEN REAR LIGHTS
 FEUX ARRIÈRE HALOGÈNES ROUNDS
 RUNDE HALOGEN-RÜCKLEUCHTEN
 PILOTOS TRASEROS HALÓGENOS REDONDOS



Articoli a ricambio

| | | | |
|--|--------------|------------------|-------------|
| | 02909 | Lente a ricambio | 02906,02907 |
| | 02934 | Lente a ricambio | 02932,02933 |



| Skù | Pos. | Brand / Brand | Tensione nominale / Rated voltage | Dimensioni / Dimensions | Interasse fori / Hole spacing | Funzioni / Functions | Lato / Side | Collegamento elettrico / Electrical connection | Note / Notes | Certificazioni / Certifications | Prodotti compatibili / Compatible products | Omologazioni / Homologations |
|--------------|------|---------------|-----------------------------------|-------------------------|-------------------------------|---|-------------|--|--|---------------------------------|--|------------------------------|
| 02906 | 1 | Ama | 12-24 V | 140x80 mm | 45 mm | Luce di posizione, indicatore di direzione, stop / Position light, direction indicator, stop light | Dx / Rh | passacavo / grommet | lampadine non incluse / bulbs not included | ECE, CE | 00397,00441, 00524,04019 | ECE |
| 02907 | 1 | Ama | 12-24 V | 140x80 mm | 45 mm | Luce di posizione, indicatore di direzione, stop, luce targa / Position light, direction indicator, stop light, license plate light | Sx / Lh | passacavo / grommet | lampadine non incluse / bulbs not included | ECE, CE | 00397,00441, 00524,04019 | ECE |
| 02932 | 2 | Cobo | 12-24 V | 115x88 mm | 45 mm | Luce di posizione, indicatore di direzione, stop / Position light, direction indicator, stop light | Dx / Rh | passacavo / grommet | lampadine non incluse / bulbs not included | ECE, CE | 00441,00524, 03874,04019 | ECE |
| 02933 | 2 | Cobo | 12-24 V | 115x88 mm | 45 mm | Luce di posizione, indicatore di direzione, stop, luce targa / Position light, direction indicator, stop light, license plate light | Sx / Lh | passacavo / grommet | lampadine non incluse / bulbs not included | ECE, CE | 00441,00524, 03874,04019 | ECE |

FANALI POSTERIORI ALOGENI RETTANGOLARI

RECTANGULAR HALOGEN REAR LIGHTS
 PHARES ARRIÈRE HALOGÈNES RECTANGULAIRES
 RECHTECKIGE HALOGEN-RÜCKLEUCHTEN
 FAROS TRASEROS HALÓGENOS RECTANGULARES

Articoli a ricambio

| | | | |
|--|--------------|------------------|--------|
| | 76485 | Lente a ricambio | 76477D |
| | 76486 | Lente a ricambio | 76477S |

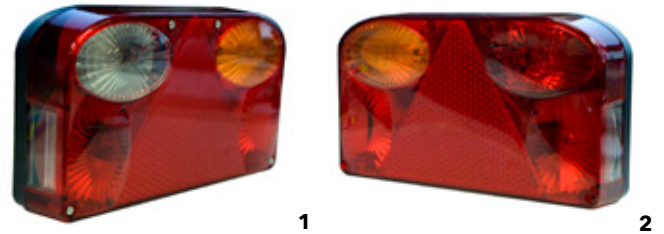

| Skù | Pos. | Tipo luce / Light type | Tensione nominale / Rated voltage | Dimensioni / Dimensions | Interasse fori / Hole spacing | Lato / Side | Collegamento elettrico / Electrical connection | Interasse fori / Hole spacing | Grado protezione ip / Degree of protection ip | Tipo lampadina / Bulb type | Note / Notes | Certificazioni / Certifications | Ricambi / Spare parts | Contenuto / Content |
|---------------|------|------------------------|-----------------------------------|-------------------------|-------------------------------|-------------|--|-------------------------------|---|----------------------------|--|---------------------------------|-----------------------|------------------------|
| 76477D | 1 | Alogeno / Halogen | 12-24 V | 237x58,6x136,5 mm | 151 mm | Dx / Rh | connettore con cavo 20 cm / connector with 20 cm cable | 151 mm | IP65 | P21/5W, P21W non include | lampadine non include / bulbs not included | ECE, CE | 17674 | Connettore controparte |
| 76477S | 2 | Alogeno / Halogen | 12-24 V | 237x58,6x136,5 mm | 151 mm | Sx / Lh | connettore con cavo 20 cm / connector with 20 cm cable | 151 mm | IP65 | P21/5W, P21W non include | lampadine non include / bulbs not included | ECE, CE | 17673 | Connettore controparte |

FANALE POSTERIORE ALOGENO RETTANGOLARE

HALOGEN REAR LIGHT RECTANGULAR
 FEU ARRIÈRE HALOGÈNE RECTANGULAIRE
 HALOGEN-RÜCKLICHT RECHTECKIG
 PILOTO TRASERO HALÓGENO, RECTANGULAR

Articoli a ricambio

| | | | |
|--|--------------|------------------|-------|
| | 59795 | Lente a ricambio | 59793 |
| | 59796 | Lente a ricambio | 59794 |

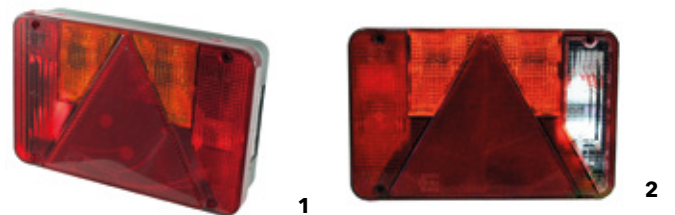

| Skù | Pos. | Funzioni / Functions | Tensione nominale / Rated voltage | Dimensioni / Dimensions | Interasse fori / Hole spacing | Lato / Side | Collegamento elettrico / Electrical connection | Note / Notes | Certificazioni / Certifications | Prodotti compatibili / Compatible products | Omologazioni / Homologations |
|--------------|------|--|-----------------------------------|-------------------------|-------------------------------|-------------|--|--|---------------------------------|--|------------------------------|
| 59793 | 1 | Luca di posizione, indicatore di direzione, stop, fendinebbia, luce targa, catadiottro / Position light, direction indicator, stop light, rear fog light, license plate light, reflector | 12-24 V | 220x60x140 mm | 70 mm | Sx / Lh | passacavo / grommet | lampadine non include / bulbs not included | ECE, CE | 00440,00441, 00501,04019 | ECE |
| 59794 | 2 | Luca di posizione, indicatore di direzione, stop, retromarcia, luce targa, catadiottro / Position light, direction indicator, stop light, reverse light, license plate light, reflector | 12-24 V | 220x60x140 mm | 71 mm | Dx / Rh | passacavo / grommet | lampadine non include / bulbs not included | ECE, CE | 00440,00441, 00501,04019 | ECE |

FANALE POSTERIORE ALOGENO RETTANGOLARE

HALOGEN REAR LIGHT RECTANGULAR
 FEU ARRIÈRE HALOGÈNE RECTANGULAIRE
 HALOGEN-RÜCKLICHT RECHTECKIG
 PILOTO TRASERO HALÓGENO, RECTANGULAR



1



2



Articoli a ricambio

| | | | |
|--|--------------|------------------|-------|
| | 17670 | Lente a ricambio | 17682 |
|--|--------------|------------------|-------|

| Skù | Pos. | Funzioni / Functions | Tensione nominale / Rated voltage | Dimensioni / Dimensions | Interasse fori / Hole spacing | Lato / Side | Collegamento elettrico / Electrical connection | Note / Notes | Certificazioni / Certifications | Prodotti compatibili / Compatible products |
|-------|------|---|-----------------------------------|-------------------------|-------------------------------|-------------|--|--|---------------------------------|---|
| 17660 | 1 | Luce di posizione, indicatore di direzione, luce stop, luce targa, retronebbia, catadiottro / Position light, direction indicator, stop light, license plate light, rear fog light, reflector | 12-24 V | 237x53x138 mm | 151 mm | Sx / Lh | connettore 4 vie / 4-way connector | lampadine non incluse / bulbs not included | ECE, CE | 00277,00440,00 441,00501,0052 6,04019,17660, 17673 |
| 17682 | 2 | Luce di posizione, indicatore di direzione, luce stop, luce targa, retronebbia, catadiottro / Position light, direction indicator, stop light, license plate light, rear fog light, reflector | 12-24 V | 237x53x138 mm | 151 mm | Dx / Rh | passacavo / grommet | lampadine non incluse / bulbs not included | ECE, CE | 00277,00440,00 441,00501,0052 6,04019,17682 |

FANALE POSTERIORE ALOGENO RETTANGOLARE

HALOGEN REAR LIGHT RECTANGULAR
 FEU ARRIÈRE HALOGÈNE RECTANGULAIRE
 HALOGEN-RÜCKLICHT RECHTECKIG
 PILOTO TRASERO HALÓGENO, RECTANGULAR



Articoli a ricambio

| | | | |
|--|--------------|--------------------------|-------------|
| | 27179 | Raccordo a ghiera 42x1,5 | 27230,27232 |
| | 27231 | Lente a ricambio | 27230 |
| | 27233 | Lente a ricambio | 27232 |



1



2

| Skù | Pos. | Funzioni / Functions | Tensione nominale / Rated voltage | Dimensioni / Dimensions | Interasse fori / Hole spacing | Lato / Side | Collegamento elettrico / Electrical connection | Note / Notes | Certificazioni / Certifications | Prodotti compatibili / Compatible products | Omologazioni / Homologations |
|-------|------|---|-----------------------------------|-------------------------|-------------------------------|-------------|--|--|---------------------------------|--|------------------------------|
| 27230 | 1 | Luce di posizione, indicatore di direzione, luce stop, retromarcia / Position light, direction indicator, stop light, Position light, direction indicator, stop light | 12-24 V | 303x82x130 mm | 170x60 mm | Dx / Rh | connettore 4 vie / 4-way connector | lampadine non incluse / bulbs not included | ECE, CE | 00397,00441, 00524,04019 | ECE |
| 27232 | 2 | Luce di posizione, indicatore di direzione, luce stop, retronebbia / Position light, direction indicator, stop light, Position light, direction indicator, rear fog light | 12-24 V | 303x82x130 mm | 170x60 mm | Sx / Lh | connettore 4 vie / 4-way connector | lampadine non incluse / bulbs not included | ECE, CE | 00397,00441, 00524,04019 | ECE |

FANALE POSTERIORE ALOGENO RETTANGOLARE

HALOGEN REAR LIGHT RECTANGULAR
 FEU ARRIÈRE HALOGÈNE RECTANGULAIRE
 HALOGEN-RÜCKLICHT RECHTECKIG
 PILOTO TRASERO HALÓGENO, RECTANGULAR

1

2
Articoli a ricambio

| | | | |
|--|--------------|------------------|-------|
| | 06574 | Lente a ricambio | 06572 |
| | 06575 | Lente a ricambio | 06573 |

| Skù | Pos. | Brand / Brand | Funzioni / Functions | Tensione nominale / Rated voltage | Dimensioni / Dimensions | Interasse fori / Hole spacing | Lato / Side | Collegamento elettrico / Electrical connection | Note / Notes | Certificazioni / Certifications | Prodotti compatibili / Compatible products | Omologazioni / Homologations |
|--------------|------|---------------|--|-----------------------------------|-------------------------|-------------------------------|-------------|--|--|---------------------------------|--|------------------------------|
| 06572 | 1 | Cobo | Luce di posizione, indicatore di direzione, stop / Position light, direction indicator, stop light | 12-24 V | 85x72x85 mm | a molla | Sx / Lh | connettore 4 vie / 4-way connector | lampadine non incluse / bulbs not included | ECE, CE | 00397,00441, 00524,04019 | ECE |
| 06573 | 2 | Cobo | Luce di posizione, indicatore di direzione, stop / Position light, direction indicator, stop light | 12-24 V | 85x72x85 mm | a molla | Dx / Rh | connettore 4 vie / 4-way connector | lampadine non incluse / bulbs not included | ECE, CE | 00397,00441, 00524,04019 | ECE |

FANALE POSTERIORE ALOGENO DX/SX RETTANGOLARE

HALOGEN REAR LIGHT RH/LH RECTANGULAR
 FEU ARRIÈRE HALOGÈNE DROIT/GAUCHE RECTANGULAIRE
 RECHTE/LINKE RECHTECKIGE HALOGEN-RÜCKLEUCHTE
 PILOTO TRASERO HALÓGENO DERECHO/IZQUIERDO RECTANGULAR

Articoli a ricambio

| | | |
|--|--------------|------------------|
| | 59773 | Lente a ricambio |
|--|--------------|------------------|

| Skù | Funzioni / Functions | Tensione nominale / Rated voltage | Dimensioni / Dimensions | Interasse fori / Hole spacing | Lato / Side | Collegamento elettrico / Electrical connection | Note / Notes | Certificazioni / Certifications | Prodotti compatibili / Compatible products | Omologazioni / Homologations |
|--------------|--|-----------------------------------|-------------------------|-------------------------------|---------------|--|--|---------------------------------|--|------------------------------|
| 59772 | Luce di posizione, indicatore di direzione, stop, retromarcia, fendinebbia, luce targa, catadiottro / Position light, direction indicator, stop light, reverse light, rear fog light, license plate light, reflector | 12-24 V | 350x85x128 mm | 152/160 mm | Dx-Sx / Rh-Lh | connettore 6 vie / 6-way connector | lampadine non incluse / bulbs not included | ECE, CE | 00397,00441, 00524,04019 | ECE |

FANALE POSTERIORE ALOGENO RETTANGOLARE

HALOGEN REAR LIGHT RECTANGULAR
 FEU ARRIÈRE HALOGÈNE RECTANGULAIRE
 HALOGEN-RÜCKLICHT RECHTECKIG
 PILOTO TRASERO HALÓGENO, RECTANGULAR



Articoli a ricambio

| | | | |
|--|--------------|--|-------|
| | 02893 | Lente dx ricambio per art. 02891, compatibile FIAT 9929835 | 02891 |
| | 02894 | Lente sx ricambio per art. 02892, compatibile FIAT 9929834 | 02892 |

| Skù | Pos. | Funzioni / Functions | Tensione nominale / Rated voltage | Dimensioni / Dimensions | Interasse fori / Hole spacing | Lato / Side | Collegamento elettrico / Electrical connection | Note / Notes | Certificazioni / Certifications | Prodotti compatibili / Compatible products | Omologazioni / Homologations |
|-------|------|---|-----------------------------------|-------------------------|-------------------------------|-------------|--|--|---------------------------------|--|------------------------------|
| 02891 | 1 | Luce di posizione, indicatore di direzione, stop / Position light, direction indicator, stop light | 12-24 V | 304x92x61 mm | 269 mm (a molla) | Dx / Rh | passacavo / grommet | lampadine non incluse / bulbs not included | ECE, CE | 00397,00441, 00524,04019 | ECE |
| 02892 | 2 | Luce di posizione, indicatore di direzione, stop, luce targa / Position light, direction indicator, stop light, license plate light | 12-24 V | 304x92x61 mm | 269 mm (a molla) | Sx / Lh | passacavo / grommet | lampadine non incluse / bulbs not included | ECE, CE | 00397,00441, 00524,04019 | ECE |

FANALE POSTERIORE ALOGENO RETTANGOLARE

HALOGEN REAR LIGHT RECTANGULAR
 FEU ARRIÈRE HALOGÈNE RECTANGULAIRE
 HALOGEN-RÜCKLICHT RECHTECKIG
 PILOTO TRASERO HALÓGENO, RECTANGULAR



Articoli a ricambio

| | | | |
|--|--------------|--|--|
| | 27229 | Lente a ricambio posteriore per art. 27227 e 27228 | |
|--|--------------|--|--|

| Skù | Brand / Brand | Tensione nominale / Rated voltage | Dimensioni / Dimensions | Interasse fori / Hole spacing | Funzioni / Functions | Lato / Side | Collegamento elettrico / Electrical connection | Fissaggio / Fastening | Note / Notes | Certificazioni / Certifications | Prodotti compatibili / Compatible products |
|-------|---------------|-----------------------------------|-------------------------|-------------------------------|--|---------------|--|------------------------|--|---------------------------------|--|
| 27227 | Ama | 12-24 V | 295x60x60 mm | 256 mm | Luce di posizione, indicatore di direzione, luce stop, catadiottero / Position light, direction indicator, stop light, reflector | Dx-Sx / Rh-Lh | passacavo / grommet | vite / screw | lampadine non incluse / bulbs not included | ECE, CE | 00440,00441, 00501,04019 |
| 27228 | Ama | 12-24 V | 295x60x60 mm | 256 mm | Luce di posizione, indicatore di direzione, luce stop, catadiottero / Position light, direction indicator, stop light, reflector | Dx-Sx / Rh-Lh | passacavo / grommet | a molla / spring mount | lampadine non incluse / bulbs not included | ECE, CE | 00440,00441, 00501,04019 |

FANALI D'INGOMBRO LED, LUCE ANTERIORE, POSTERIORE E LATERALE

LED MARKER LIGHTS, FRONT, REAR AND SIDE LIGHT
 FEUX DE GABARIT LED, ÉCLAIRAGE AVANT, ARRIÈRE ET LATÉRAL
 LED-POSITIONSLEUCHTEN, MIT FRONT-, HECK- UND SEITENLICHT
 LUCES DE GÁLIBO LED, LUZ DELANTERA, TRASERA Y LATERAL

1

2

3

| Skü | Pos. | Tensione nominale / Rated voltage | Lato / Side | Collegamento elettrico / Electrical connection | Colore / Colour | Fissaggio / Fastening | Omologazioni / Homologations | Interasse fori / Hole spacing |
|--------------|------|-----------------------------------|-------------|--|---|---|------------------------------|-------------------------------|
| 55340 | 1 | 12-24 V | dx / rh | Cavo 50 cm 2x0,75 mm ² / 50 cm cable 2x0.75 mm ² | Rosso, bianco, arancione / Red, white, orange | Staffa in gomma con rinforzo in metallo / Metal-reinforced rubber bracket | ECE | 77 mm |
| 55341 | 1 | 12-24 V | sx / lh | Cavo 50 cm 2x0,75 mm ² / 50 cm cable 2x0.75 mm ² | Rosso, bianco, arancione / Red, white, orange | Staffa in gomma con rinforzo in metallo / Metal-reinforced rubber bracket | ECE | 77 mm |
| 63102 | 2 | 12-24 V | dx / rh | Cavo 50 cm 2x0,75 mm ² / 50 cm cable 2x0.75 mm ² | Rosso, bianco, arancione / Red, white, orange | Staffa in gomma con rinforzo in metallo / Metal-reinforced rubber bracket | ECE | 77 mm |
| 63103 | 3 | 12-24 V | sx / lh | Cavo 50 cm 2x0,75 mm ² / 50 cm cable 2x0.75 mm ² | Rosso, bianco, arancione / Red, white, orange | Staffa in gomma con rinforzo in metallo / Metal-reinforced rubber bracket | ECE | 77 mm |

FANALI D'INGOMBRO LATERALI LED

SIDE LED MARKER LIGHTS
 FEUX DE GABARIT LATÉRAUX LED
 SEITLICHE LED-POSITIONSLEUCHTEN
 LUCES DE GÁLIBO LATERALES LED

1

2

3

| Skü | Pos. | Tensione nominale / Rated voltage | Lato / Side | Collegamento elettrico / Electrical connection | Colore / Colour | Fissaggio / Fastening | Omologazioni / Homologations | Interasse fori / Hole spacing |
|--------------|------|-----------------------------------|---------------|---|--------------------------------|---|------------------------------|-------------------------------|
| 75433 | 1 | 12-24 V | Dx-Sx / Rh-Lh | Cavo 30 cm 2x0,75 mm / 30 cm cable 2x0.75 mm ² | Rosso e Bianco / Red and white | staffa in gomma con rinforzo in metallo / Rubber bracket with metal reinforcement | ECE | 76 mm |
| 75434 | 2 | 12-24 V | Dx-Sx / Rh-Lh | Cavo 30 cm 2x0,75 mm / 30 cm cable 2x0.75 mm ² | Rosso e Bianco / Red and white | staffa in gomma con rinforzo in metallo / Rubber bracket with metal reinforcement | ECE | 76 mm |
| 75435 | 3 | 12-24 V | Dx-Sx / Rh-Lh | Cavo 30 cm 2x0,75 mm / 30 cm cable 2x0.75 mm ² | Rosso e Bianco / Red and white | staffa in gomma con rinforzo in metallo / Rubber bracket with metal reinforcement | ECE | 76 mm |

LUCE DI INGOMBRO ALOGENA LATERALE, LUCE BIANCA E ROSSA

HALOGEN SIDE CLEARANCE LIGHT, WHITE AND RED LIGHT
 FEU DE GABARIT HALOGÈNE LATÉRAL, LUMIÈRE BLANCHE ET ROUGE
 HALOGEN-SEITEN-BORDSTECKLEUCHTE, WEISSE UND ROTE LAMPE
 LUZ DE GÁLIBO HALÓGENA LATERAL, LUZ BLANCA Y ROJA



Articoli a ricambio

| | | |
|--|--------------|--|
| | 00397 | Lampadina alogena R5W 12V 5W BA15s |
| | 00524 | Lampadina alogena R5W 24V 5W BA15s |
| | 77747 | Lente bianca/trasparente per art. 77745 e 77746 |
| | 77748 | Lente rossa per art. 77745 e 77746 |

| Skü | Pos. | Tensione nominale / Rated voltage | Lato / Side | Colore / Colour | Collegamento elettrico / Electrical connection | Fissaggio / Fastening | Interasse fori / Hole spacing | Note / Notes | Omologazioni / Homologations |
|--------------|------|-----------------------------------|---------------|--------------------------|--|----------------------------------|-------------------------------|---|------------------------------|
| 77745 | 1 | 12-24 V | dx-sx / rh-lh | Bianco-rosso / White-red | cavo 230 mm / cable 230 mm | Viti M6 (non incluse) / M6 screw | 78 | Lampadine non incluse / Bulb not included | ECE |
| 77746 | 2 | 12-24 V | dx-sx / rh-lh | Bianco-rosso / White-red | cavo 230 mm / cable 230 mm | Viti M6 (non incluse) / M6 screw | 77 | Lampadine non incluse / Bulb not included | ECE |

KIT 2 PZ FANALI DI INGOMBRO A LED DESTRO E SINISTRO

LED MARKER LIGHT KIT (2PCS), RIGHT AND LEFT
 KIT DE 2 FEUX DE GABARIT LED, DROIT ET GAUCHE
 2-TEILIGER LED-POSITIONSLEUCHTEN-KIT, RECHTS UND LINKS
 KIT DE 2 LUCES DE GÁLIBO LED, DERECHA E IZQUIERDA



| Skü | Tensione nominale / Rated voltage | Lato / Side | Collegamento elettrico / Electrical connection | Colore / Colour | Fissaggio / Fastening | Interasse fori / Hole spacing | Omologazioni / Homologations |
|--------------|-----------------------------------|---------------------|--|--------------------------|--|-------------------------------|------------------------------|
| 55352 | 12-24 V | Dx e Sx / Rh and Lh | Cavo 30 cm 2x0,75 mm ² / 30 cm cable 2x0.75 mm ² | bianco-rosso / white-red | Staffa in gomma con rinforzo metallo / Rubber bracket with metal reinforcement | 41 mm | ECE |

FANALI D'INGOMBRO LED

LED MARKER LIGHTS
FEUX DE GABARIT LED
LED-POSITIONSLEUCHTEN
LUCES DE GÁLIBO LED

1
2
3

| Skü | Pos. | Tensione nominale / Rated voltage | Lato / Side | Collegamento elettrico / Electrical connection | Colore / Colour | Fissaggio / Fastening | Omologazioni / Homologations | Interasse fori / Hole spacing |
|--------------|------|--------------------------------------|---------------|---|-----------------------|----------------------------------|---------------------------------|----------------------------------|
| 85461 | 1 | 12-24 V | Dx-sx / Rh-Lh | Cavo 50 cm 2x0,75 mm ² / 50 cm cable 2x0.75 mm ² | Bianco / White | Staffa in PMMA / PMMA bracket | ECE | 20/30-50 mm |
| 85462 | 2 | 12-24 V | Dx-sx / Rh-Lh | Cavo 50 cm 2x0,75 mm131 / 50 cm cable 2x0.75 mm ² | Arancione / Orange | Staffa in PMMA / PMMA bracket | ECE | 20/30-50 mm |
| 85463 | 3 | 12-24 V | Dx-sx / Rh-Lh | Cavo 50 cm 2x0,75 mm132 / 50 cm cable 2x0.75 mm ² | Rosso / Red | Staffa in PMMA / PMMA bracket | ECE | 20/30-50 mm |

FANALI D'INGOMBRO LED

LED MARKER LIGHTS
FEUX DE GABARIT LED
LED-POSITIONSLEUCHTEN
LUCES DE GÁLIBO LED

1
2
3

| Skü | Pos. | Tensione nominale / Rated voltage | Lato / Side | Collegamento elettrico / Electrical connection | Colore / Colour | Fissaggio / Fastening | Omologazioni / Homologations | Interasse fori / Hole spacing |
|--------------|------|--------------------------------------|---------------|---|-----------------------|----------------------------------|---------------------------------|----------------------------------|
| 64522 | 1 | 12-24 V | Dx-SX / Rh-Lh | Cavo 50 cm / Cable 50 cm | Bianco / White | Staffa in PMMA / PMMA bracket | ECE | 116 mm |
| 64523 | 2 | 12-24 V | Dx-SX / Rh-Lh | Cavo 50 cm / Cable 50 cm | Arancione / Orange | Staffa in PMMA / PMMA bracket | ECE | 116 mm |
| 64524 | 3 | 12-24 V | Dx-SX / Rh-Lh | Cavo 50 cm / Cable 50 cm | Rosso / Red | Staffa in PMMA / PMMA bracket | ECE | 116 mm |

FANALE D'INGOMBRO ALOGENO ARANCIONE

HALOGEN CLEARANCE LIGHT, ORANGE
FEU DE GABARIT HALOGÈNE, ORANGE
HALOGEN-BORDSTECKLEUCHTE, ORANGE
LUZ DE GÁLIBO HALÓGENA, NARANJA

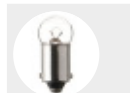
Articoli a ricambio

00397 Lampadina alogena R5W 12V 5W
BA15s



00524 Lampadina alogena R5W 24V 5W
BA15s

| Skü | Tensione nominale / Rated voltage | Lato / Side | Colore / Colour | Collegamento elettrico / Electrical connection | Fissaggio / Fastening | Interasse fori / Hole spacing | Note / Notes | Omologazioni / Homologations |
|--------------|--------------------------------------|---------------|-----------------------|---|--|----------------------------------|--|---------------------------------|
| 55358 | 12-24 V | dx-sx / rh-lh | Arancione / Orange | passacavo / grommet | Staffa, fori Ø 5,1 mm / Bracket, Ø 5,1 mm holes | 29 mm | Lampadina non inclu- sa / Bulb not included | ECE |

FANALE D'INGOMBRO ALOGENO TRASPARENTE/ROSSO

HALOGEN CLEARANCE LIGHT, CLEAR/RED

FEU DE GABARIT HALOGÈNE, TRANSPARENT/ROUGE

HALOGEN-BORDSTECKLEUCHTE, KLAR/ROT

LUZ DE GÁLIBO HALÓGENA, TRANSPARENTE/ROJA

**Articoli a ricambio****00397**Lampadina alogena R5W 12V 5W
BA15s**00524**Lampadina alogena R5W 24V 5W
BA15s

| Skù | Tensione nominale / Rated voltage | Lato / Side | Colore / Colour | Collegamento elettrico / Electrical connection | Fissaggio / Fastening | Interasse fori / Hole spacing | Note / Notes | Omologazioni / Homologations |
|-------|-----------------------------------|---------------|------------------------------|--|---|-------------------------------|---|------------------------------|
| 47176 | 12-24 V | dx-sx / rh-lh | Bianco - rosso / White - red | passacavo Ø 4 mm / Grommet Ø 4 mm | Staffa in gomma, fori Ø 6,5 mm / Rubber bracket, Ø 6.5 mm holes | 20 mm | Lampadina non inclusa / Bulb not included | ECE / ECE R7 |

FANALI DI POSIZIONE

POSITION LIGHTS

FEUX DE POSITION

POSITIONSLEUCHTEN

LUCES DE POSICIÓN



1



2

| Skù | Pos. | Tensione nominale / Rated voltage | Lato / Side | Collegamento elettrico / Electrical connection | Colore / Colour | Omologazioni / Homologations | Note / Notes | Prodotti compatibili / Compatible products | Omologazioni / Homologations |
|-------|------|-----------------------------------|---------------|--|---------------------|------------------------------|---|--|------------------------------|
| 59118 | 1 | 12-24 V | dx-sx / rh-lh | passacavo / grommet | rosso / red | ECE | Lampadina R5W non inclusa / R5W bulb not included | 00397,00524 | ECE |
| 59126 | 2 | 12-24 V | dx-sx / rh-lh | passacavo / grommet | trasparente / white | ECE | Lampadina R5W non inclusa / R5W bulb not included | 00397,00524 | ECE |

FANALI DI POSIZIONE

POSITION LIGHTS

FEUX DE POSITION

POSITIONSLEUCHTEN

LUCES DE POSICIÓN



1



2

| Skù | Pos. | Lato / Side | Collegamento elettrico / Electrical connection | Colore / Colour | Note / Notes | Interasse fori / Hole spacing | Prodotti compatibili / Compatible products |
|-------|------|---------------|--|-----------------|---|-------------------------------|--|
| 27234 | 1 | dx/sx / rh/lh | passacavo / grommet | rosso / red | Lampadina non inclusa / Bulb not included | 70 mm | 00277,00526 |
| 27235 | 2 | dx/sx / rh/lh | passacavo / grommet | bianco / white | Lampadina non inclusa / Bulb not included | 70 mm | 00277,00526,27168 |

LUCE DI POSIZIONE CON CATADIOTTRO ALOGENO

HALOGEN MARKER LIGHT WITH REFLECTOR
 FEU DE GABARIT HALOGÈNE AVEC CATADIOPTRE
 HALOGEN-POSITIONSLEUCHTE MIT RÜCKSTRAHLER
 LUZ DE GÁLIBO HALÓGENA CON CATADIÓPTICO



| Skü | Tensione nominale / Rated voltage | Lato / Side | Colore / Colour | Interasse fori / Hole spacing | Collegamento elettrico / Electrical connection | Note / Notes | Omologazioni / Homologations | Prodotti compatibili / Compatible products |
|--------------|-----------------------------------|---------------|---|-------------------------------|--|---|------------------------------|--|
| 51687 | 12-24 V | dx-sx / rh-lh | Bianco con catadiottro / White with reflector | 28,5 mm | passacavo / grommet | Lampadina non inclusa / Bulb not included | ECE | 00277,00526 |

FANALE INDICATORE DI DIREZIONE LED 12-24V, DIAMETRO 95 MM

LED DIRECTION INDICATOR LIGHT 12-24V, 95 MM DIAMETER
 CLIGNOTANT LED 12-24V, DIAMÈTRE 95 MM
 LED-BLINKLEUCHTE 12-24V, DURCHMESSER 95 MM
 INTERMITENTE LED 12-24V, DIÁMETRO 95 MM



| Skü | Tensione nominale / Rated voltage | Lato / Side | Collegamento elettrico / Electrical connection | Colore / Colour | Diametro / Diameter | Interasse fori / Hole spacing | Omologazioni / Homologations |
|--------------|-----------------------------------|---------------|--|--------------------|---------------------|-------------------------------|------------------------------|
| 84675 | 12-24 V | dx-sx / rh-lh | cavo 15 cm / cable 15 cm | arancione / orange | 95 mm | 80 mm | ECE |

FANALE INDICATORE DI DIREZIONE ALOGENO

HALOGEN INDICATOR LIGHT
 CLIGNOTANT HALOGÈNE
 HALOGEN-BLINKLEUCHTE
 INTERMITENTE HALÓGENO

Articoli a ricambio

05585 Lente a ricambio per indicatore di direzione per art. 05538



05586 Lente a ricambio per indicatore di direzione per art. 05539

| Skü | Tensione nominale / Rated voltage | Lato / Side | Dimensioni / Dimensions | Interasse fori / Hole spacing | Colore / Colour | Certificazioni / Certifications | Collegamento elettrico / Electrical connection | Note / Notes | Prodotti compatibili / Compatible products |
|--------------|-----------------------------------|-------------|-------------------------|-------------------------------|--------------------|---------------------------------|--|---|--|
| 05538 | 12-24 V | dx / right | 85x54 mm | 46 mm | arancione / orange | ECE | passacavo / grommet | Lampadina non inclusa / Bulb not included | 00441,04019 |
| 05539 | 12-24 V | sx / left | 85x54 mm | 46 mm | arancione / orange | ECE | passacavo / grommet | Lampadina non inclusa / Bulb not included | 00441,04019 |

FANALE INDICATORE DI DIREZIONE ALOGENO

HALOGEN INDICATOR LIGHT
CLIGNOTANT HALOGÈNE
HALOGEN-BLINKLEUCHTE
INTERMITENTE HALÓGENO



| Skü | Tensione nominale / Rated voltage | Lato / Side | Dimensioni / Dimensions | Interasse fori / Hole spacing | Colore / Colour | Collegamento elettrico / Electrical connection | Note / Notes | Prodotti compatibili / Compatible products | Certificazioni / Certifications |
|-------|-----------------------------------|---------------|-------------------------|-------------------------------|--------------------|--|---|--|---------------------------------|
| 00412 | 12-24 V | dx-sx / rh-lh | 108x40x57 mm | 93 mm | arancione / orange | passacavo / grommet | Lampadina non inclusa / Bulb not included | 00397,00524 | ECE |

FANALE INDICATORE DI DIREZIONE ALOGENO

HALOGEN INDICATOR LIGHT
CLIGNOTANT HALOGÈNE
HALOGEN-BLINKLEUCHTE
INTERMITENTE HALÓGENO

Articoli a ricambio

02868 Lente a ricambio 02867

| Skü | Tensione nominale / Rated voltage | Lato / Side | Interasse fori / Hole spacing | Collegamento elettrico / Electrical connection | Colore / Colour | Prodotti compatibili / Compatible products |
|-------|-----------------------------------|---------------|-------------------------------|--|--------------------|--|
| 02867 | 12-24 V | dx-sx / rh-lh | 78 mm | passacavo / grommet | arancione / orange | 00277,00526 |

FANALE FRECCIA ALOGENO ARANCIONE

HALOGEN INDICATOR LIGHT, ORANGE
FEU DE CLIGNOTANT HALOGÈNE, ORANGE
HALOGEN-BLINKLICHT, ORANGE
LUZ INTERMITENTE HALÓGENA, NARANJA

Articoli a ricambio

27167 Lente a ricambio

| Skü | Brand / Brand | Tensione nominale / Rated voltage | Dimensioni / Dimensions | Lato / Side | Interasse fori / Hole spacing | Collegamento elettrico / Electrical connection | Colore / Colour | Note / Notes | Prodotti compatibili / Compatible products | Certificazioni / Certifications |
|-------|---------------|-----------------------------------|-------------------------|---------------|-------------------------------|--|--------------------|---|--|---------------------------------|
| 27236 | Cobo | 12-24 V | 93x36x54 mm | dx-sx / rh-lh | 70 mm | passacavo / grommet | Arancione / Orange | Lampadina non inclusa / Bulb not included | 00277,00526 | ECE |

FANALE FRECCIA ALOGENO LATERALE

HALOGEN SIDE INDICATOR LIGHT
CLIGNOTANT LATÉRAL HALOGÈNE
HALOGEN-SEITENBLINKLEUCHTE
INTERMITENTE LATERAL HALÓGENO



| Skü | Tensione nominale / Rated voltage | Lato / Side | Dimensioni / Dimensions | Collegamento elettrico / Electrical connection | Colore / Colour | Note / Notes | Prodotti compatibili / Compatible products | Omologazioni / Homologations |
|--------------|--------------------------------------|---------------|----------------------------|---|-----------------------|--|---|---------------------------------|
| 00696 | 12-24 V | dx-sx / rh-lh | 42x39 mm | faston 6,3 mm | Arancione / Orange | Lampadina non inclusa / Bulb not included | 00398 | ECE |

FANALE INDICATORE DI DIREZIONE ALOGENO

HALOGEN INDICATOR LIGHT
CLIGNOTANT HALOGÈNE
HALOGEN-BLINKLEUCHTE
INTERMITENTE HALÓGENO



| Skü | Tensione nominale / Rated voltage | Lato / Side | Dimensioni / Dimensions | Collegamento elettrico / Electrical connection | Colore / Colour | Note / Notes | Prodotti compatibili / Compatible products | Certificazioni / Certifications |
|--------------|--------------------------------------|---------------|----------------------------|---|---------------------|--|---|------------------------------------|
| 60148 | 12-24 V | dx-sx / rh-lh | 42x70 mm | passacavo / grommet | Arancio / Orange | Lampadina non inclusa / Bulb not included | 00451,00525 | ECE |

FANALE LED RETRONEBBIA E RETROMARCIA 12V

LED REAR FOG LIGHT AND REVERSE LIGHT 12V
FEU LED ANTIBROUILLARD ARRIÈRE ET FEU LED DE RECUŁ 12V
LED-NEBELSCHLUSSLEUCHTE UND RÜCKFAHRLUCHTE 12V
LUZ ANTINIEBLA TRASERA Y LUZ DE MARCHA ATRÁS LED 12V



| Skü | Pos. | Tensione nominale / Rated voltage | Funzioni / Functions | Colore / Colour | Lumen | Dimensioni / Dimensions | Interasse fori / Hole spacing | Collegamento elettrico / Electrical connection | Certificazioni / Certifications | Omologazioni / Homologations |
|--------------|------|--------------------------------------|---------------------------------|--------------------|-------|----------------------------|----------------------------------|---|------------------------------------|---------------------------------|
| 84498 | 1 | 12 V | Retromarcia / Reverse light | bianco / white | 110 | 100,7x28,5x80,7 mm | 65 mm | cavo 15 cm / cable 15 cm | ECE, CE, Rohs | ECE |
| 84499 | 2 | 12 V | Retronebbia / Rear fog light | rosso / red | 110 | 100,7x28,5x80,7 mm | 65 mm | cavo 15 cm / cable 15 cm | ECE, CE, Rohs | ECE |

FANALE LED RETRONEBBIA E RETROMARCIA 9-34V DIAMETRO 140 MM

LED REAR FOG AND REVERSE LIGHT 12V, 140 MM DIAMETER

FANALE LED RETRONEBBIA E RETROMARCIA 9-34V DIAMETRO 140 MM

LED-NEBELSCHLUSS- UND RÜCKFAHRLEUCHTE 9-34V, DURCHMESSER 140 MM

LUZ LED ANTINEBLA TRASERA Y DE MARCHA ATRÁS 9-34V, DIÁMETRO 140 MM



1



2

| Sku | Pos. | Tensione nominale / Rated voltage | Funzioni / Functions | Colore / Colour | Diametro / Diameter | Interasse fori / Hole spacing | Collegamento elettrico / Electrical connection | Temperatura di esercizio / Operating temperature | Grado protezione ip / Degree of protection ip | Certificazioni / Certifications | Omologazioni / Homologations |
|-------|------|-----------------------------------|-----------------------------|-----------------|---------------------|-------------------------------|--|--|---|---------------------------------|------------------------------|
| 84671 | 1 | 9-34 V | Fendinebbia / Fog light | rosso / red | 140 mm | 45 mm | faston 6,3 mm | -40° C / +60° C | IP67 | ECE, CE, Rohs | ECE |
| 84672 | 2 | 9-34 V | Retromarcia / Reverse light | bianco / white | 140 mm | 45 mm | faston 6,3 mm | -40° C / +60° C | IP67 | ECE, CE, Rohs | ECE |

FANALE RETRONEBBIA E RETROMARCIA ALOGENO

HALOGEN REAR FOG LIGHT AND REVERSE LIGHT

FEU ANTIBROUILLARD ARRIÈRE ET FEU DE REcul HALOGÈNES

HALOGEN-NEBELSCHLUSSLEUCHTE UND RÜCKFAHRLEUCHTE

LUZ ANTINEBLA TRASERA Y LUZ DE MARCHA ATRÁS HALÓGENAS



1



2

| Sku | Pos. | Tensione nominale / Rated voltage | Funzioni / Functions | Colore / Colour | Dimensioni / Dimensions | Interasse fori / Hole spacing | Collegamento elettrico / Electrical connection | Note / Notes | Prodotti compatibili / Compatible products | Certificazioni / Certifications |
|-------|------|-----------------------------------|------------------------------|-----------------|-------------------------|-------------------------------|--|---|--|---------------------------------|
| 04356 | 1 | 12-24 V | Retronebbia / Reverse light | rosso / red | 85,5x49,5x75,5 mm | 53 mm | passacavo / grommet | Lampadina non inclusa / Bulb not included | 00441,04019 | ECE |
| 04357 | 2 | 12-24 V | Retromarcia / Rear fog light | bianco / white | 85,5x49,5x75,5 mm | 53 mm | passacavo / grommet | Lampadina non inclusa / Bulb not included | 00441,04019 | ECE |

FANALI LED LUCE TARGA

LED LICENSE PLATE LIGHTS
 FEUX DE PLAQUE D'IMMATRICULATION LED
 LED-KENNZEICHENBELEUCHTUNG
 LUCES DE MATRÍCULA LED



| Skü | Pos. | Tipo luce / Light type | Tensione nominale / Rated voltage | Dimensioni / Dimensions | Interasse fori / Hole spacing | Fissaggio / Fastening | Certificazioni / Certifications |
|-------|------|------------------------|-----------------------------------|-------------------------|-------------------------------|--------------------------|---------------------------------|
| 55268 | 3 | LED | 12-24 V | 112x49x48,8 mm | 45 e 72 mm / 45 and 72 mm | Viti M5/ M5 screws | CE / ECE |
| 81219 | 2 | LED | 12-24 V | 83x30,5x40 mm | 45 mm | Viti M5/ M5 screws | CE |
| 55457 | 1 | LED | 12-24 V | 68x35x37,5 mm | 45 mm | Viti M5x20/ M5x20 screws | CE, RoHS |

FANALI LUCE TARGA ALOGENI

HALOGEN LICENSE PLATE LIGHTS
 FEUX DE PLAQUE D'IMMATRICULATION HALOGÈNES
 HALOGEN-KENNZEICHENBELEUCHTUNG
 LUCES DE MATRÍCULA HALÓGENAS



| Skü | Pos. | Brand / Brand | Tipo luce / Light type | Dimensioni / Dimensions | Interasse fori / Hole spacing | Tensione nominale / Rated voltage | Fissaggio / Fastening | Note / Notes | Prodotti compatibili / Compatible products | Omologazioni / Homologations |
|-------|------|---------------|------------------------|-------------------------|-------------------------------|-----------------------------------|-----------------------|---|--|------------------------------|
| 00405 | 1 | Radex | Alogeno / Halogen | 83x32,6x30 mm | 45 mm | 12-24 V | viti M6 / M6 screws | Lampadina non inclusa / Bulb not included | 00277,00526 | ECE |
| 15861 | 2 | Hella | Alogeno / Halogen | 80x28x31 mm | 45 mm | 12-24 V | viti M6 / M6 screws | Lampadina non inclusa / Bulb not included | 00277,00526 | ECE |
| 26166 | 3 | Cobo | Alogeno / Halogen | 140x44x47 mm | 125 mm | 12-24 V | viti M5 / M5 screws | Lampadina non inclusa / Bulb not included | 00397,00524 | ECE |



Kit luci e rimorchi

Light kits for trailers
and agricultural vehicles

I prodotti recanti il marchio AMA qui indicati sono realizzati da AMA S.p.A. e destinati a essere utilizzati come ricambi adattabili e non originali. I riferimenti a marchi, codici originali e costruttori di terzi, riportati in corrispondenza degli articoli AMA compatibili, hanno esclusivamente la finalità di identificare il modello, l'applicazione o la destinazione d'uso del prodotto, in conformità a quanto previsto dal Regolamento (CE) n. 1400/2002 e dalla normativa vigente in materia di concorrenza e uso lecito dei marchi di terzi. / The products bearing the AMA brand name listed here are manufactured by AMA S.p.A. and are intended for use as adaptable, non-original spare parts. References to trademarks, original codes and third-party manufacturers, shown alongside compatible AMA items, are intended solely to identify the model, application or intended use of the product, in accordance with Regulation (EC) No. 1400/2002 and current legislation on competition and the lawful use of third-party trademarks.

KIT LUCI POSTERIORI LED WIRELESS MAGNETICO

WIRELESS LIGHT SET LED MAGNETIC

KIT SIGNALISATION FEUX LED ARRIÈRE SANS FIL MAGNETIQUE

BELEUCHTUNGSSATZ LED MAGNETHALTERUNG WIEDERAUFLADBAR

JUEGO DE LUCES INALÁMBRICO LED MAGNÉTICO

Articoli a ricambio

| | | | |
|--|--------------|--|-------------|
| | 66002 | Fanale posteriore LED dx 12V per kit wireless ricaricabile 66001 | 66001 |
| | 66003 | Fanale posteriore LED sx 12V per kit wireless ricaricabile 66001 | 66001 |
| | 66004 | Spina 7 poli con antenna | 66001,77007 |

| SKU | Tipo luce / Light type | Tensione nominale / Rated voltage | Funzioni / Functions | Collegamento elettrico / Electrical connection | Fissaggio / Fastening | Note / Notes | Temperatura di esercizio / Operating temperature | Grado protezione ip / Degree of protection ip | Omologazioni / Homologations |
|--------------|------------------------|-----------------------------------|--|--|--|---|--|---|------------------------------|
| 66001 | LED | 12 V | Luce posteriore, indicatore di direzione, luce targa, stop / Rear light, turn signal, license plate light, brake light | Spina 7 poli wireless / 7-pole wireless plug | Posteriore, con magnete / Rear light with magnetic mount | Autonomia della batteria 8 ore, raggio di comunicazione radio 30 metri / Battery life up to 8 hours, radio range up to 30 m | -25° C / +65° C | IP65 | ECE |

KIT LUCI POSTERIORI MAGNETICI LED WIRELESS

WIRELESS MAGNETIC LED REAR LIGHT KIT

KIT FEUX ARRIÈRE LED SANS FIL MAGNÉTIQUES

KABELLOSES MAGNETISCHES LED-RÜCKLEUCHTENSET

KABELLOSES MAGNETISCHES LED-RÜCKLEUCHTENSET



Articoli a ricambio

| | | | |
|--|--------------|---|-------------|
| | 66004 | Spina 7 poli con antenna | 66001,77007 |
| | 77002 | Fanale posteriore LED dx 12-24V per kit wireless ricaricabile 77001 | 77001 |
| | 77003 | Fanale posteriore LED sx 12-24V per kit wireless ricaricabile 77001 | 77001 |
| | 77004 | Spina 7 poli wireless ricambio per art. 77001 | 77001 |
| | 77005 | Caricatore USB, ricambio per art. 77001 | 77001 |
| | 77009 | Fanale posteriore LED dx 12V per kit wireless ricaricabile 77007 | 77007 |
| | 77010 | Fanale posteriore LED sx 12V per kit wireless ricaricabile 77007 | 77007 |

| Skù | Pos. | Tipo luce / Light type | Tensione nominale / Rated voltage | Funzioni / Functions | Collegamento elettrico / Electrical connection | Fissaggio / Fastening | Note / Notes | Descrizione / Description | Temperatura di esercizio / Operating temperature | Grado protezione ip / Degree of protection ip | Omologazioni / Homologations |
|--------------|------|------------------------|-----------------------------------|---|--|--|---|--|--|---|-------------------------------------|
| 77001 | 1 | LED | 12-24V | Luce posteriore, indicatore di direzione, luce targa, stop, retronebbia / Rear light, turn signal, license plate light, brake light | Spina 7 poli wireless / 7-pin wireless connector | Posteriore, con magnetite / Rear light with magnetic mount | Autonomia della batteria 18 ore, raggio di comunicazione radio 30 metri / Battery life: 8 hours, radio communication range: 30 m | Caricatore accendisigari: permette la visualizzazione delle singole funzioni dei fanali e lo stato di carica della batteria / Cigarette lighter charger: allows the display of individual tail-light functions and the battery's state of charge | -40°C ~ +65°C | IP67 | ECE, EN 301489, EN 300328, EN 62479 |
| 77007 | 2 | LED | 12V | Luce posteriore, indicatore di direzione, luce targa, stop, retronebbia / Rear light, turn signal, license plate light, brake light | Spina 7 poli wireless / 7-pin wireless connector | Posteriore, con magnetite / Rear light with magnetic mount | Autonomia della batteria 10 ore, raggio di comunicazione radio 30 metri / Battery life: 10 hours, radio communication range: 30 m | | -40°C ~ +65°C | IP67 | ECE, EN 301489, EN 300328, EN 62479 |

KIT LUCI POSTERIORI A LED 12-24V

LED REAR LIGHT KIT 12-24V
 KIT DE FEUX ARRIÈRE LED
 LED-RÜCKLEUCHTEN-SET 12-24V
 KIT DE LUCES TRASERAS LED 12-24V



| Skü | Pos. | Tipo luce / Light type | Tensione nominale / Rated voltage | Funzioni / Functions | Lunghezza cavo / Cable length | Collegamento elettrico / Electrical connection | Fissaggio / Fastening |
|--------------|------|------------------------|-----------------------------------|---|--|--|--|
| 76490 | 1 | LED | 12-24 V DC | Luce di posizione, indicatore di direzione, stop, luce targa / Position light, turn indicator, brake light, license plate light | Fanale-spina 7 poli: 7,5 m; fanale-fanale: 2,5 m / Light to 7-pin plug: 7.5 m; light to light: 2.5 m | Spina 7 poli / 7-pin plug | posteriore, con magneti / Rear, with magnets |
| 76491 | 2 | LED | 12-24 V DC | Luce di posizione, indicatore di direzione, stop, luce targa / Position light, turn indicator, brake light, license plate light | Fanale-spina 7 poli: 7,5 m; fanale-fanale: 2,5 m / Light to 7-pin plug: 7.5 m; light to light: 2.5 m | Spina 7 poli / 7-pin plug | posteriore, con magneti / Rear, with magnets |
| 76492 | 3 | LED | 12-24 V DC | Luce di posizione, indicatore di direzione, stop, luce targa / Position light, turn indicator, brake light, license plate light | Fanale-spina 7 poli: 7,5 m; fanale-fanale: 2,5 m / Light to 7-pin plug: 7.5 m; light to light: 2.5 m | Spina 7 poli / 7-pin plug | posteriore, con viti / Rear, with screws |

KIT LUCI POSTERIORI LED MAGNETICO

REAR LIGHT LED SET MAGNETIC
 KIT SIGNALISATION FEUX ARRIÈRE LED MAGNETIQUE
 BELEUCHTUNGSSATZ LED MAGNETHALTERUNG
 JUEGO DE LUCES LED MAGNÉTICO

Articoli a ricambio

| | | |
|--|--------------|---|
| | 02929 | Spina 7 poli 12-24V in plastica con chiusura a vite e cappuccio |
| | 03426 | Kit magnetico per girofaro |
| | 75275 | Fanale posteriore LED dx/sx 13,5V 105,6x36,4x 97,9 mm |

| Skü | Tipo luce / Light type | Tensione nominale / Rated voltage | Funzioni / Functions | Lunghezza cavo / Cable length | Collegamento elettrico / Electrical connection | Fissaggio / Fastening | Temperatura di esercizio / Operating temperature | Omologazioni / Homologations |
|--------------|------------------------|-----------------------------------|--|---|--|---|--|------------------------------|
| 75991 | LED | 12 V | Luce di posizione, indicatore di direzione, stop, luce targa, catarifrangente / Position light, turn signal, brake light, license plate light, reflector | lunghezza 7,5 m / 2,5 m tra fanali / 7.5 m + 2.5 m between lighting units | Spina 7 poli / 7-pin plug | Posteriore, con magneti / Rear, with magnetic mount | -20° C / +50° C | ECE |
| 75992 | LED | 12 V | Luce di posizione, indicatore di direzione, stop, luce targa, catarifrangente / Position light, turn signal, brake light, license plate light, reflector | lunghezza 12 m / 4 m tra fanali / 12 m + 4 m between lighting units | Spina 7 poli / 7-pin plug | Posteriore, con magneti / Rear, with magnetic mount | -20° / +50° C | ECE |
| 75993 | LED | 12 V | Luce di posizione, indicatore di direzione, stop, luce targa, catarifrangente / Position light, turn signal, brake light, license plate light, reflector | lunghezza 14 m / 4 m tra fanali / 14 m + 4 m between lighting units | Spina 7 poli / 7-pin plug | Posteriore, con magneti / Rear, with magnetic mount | -20° / +50° C | ECE |

KIT LUCI POSTERIORI LED CON MAGNETE, TRIANGOLI, 12 M + 2,5 M

LED REAR LIGHT KIT WITH MAGNET, TRIANGLES, 12 M + 2.5 M
 KIT FEUX ARRIÈRE LED AVEC AIMANT, TRIANGLES, 12 M + 2,5 M
 LED-RÜCKLEUCHTENSATZ MIT MAGNET, DREIECKE, 12 M + 2,5 M
 KIT DE LUCES TRASERAS LED CON IMÁN, TRIÁNGULOS, 12 M + 2,5 M



Articoli a ricambio

| | | |
|---|--------------|---|
|  | 02929 | Spina 7 poli 12-24V in plastica con chiusura a vite e cappuccio |
|  | 03426 | Kit magnetico per girofaro |
|  | 10370 | Triangolo rifrangente rosso con fori |
|  | 75275 | Fanale posteriore LED dx/sx 13,5V 105,6x36,4x 97,9 mm |



| Skù | Tipo luce / Light type | Tensione nominale / Rated voltage | Funzioni / Functions | Lunghezza cavo / Cable length | Collegamento elettrico / Electrical connection | Fissaggio / Fastening | Temperatura di esercizio / Operating temperature | Omologazioni / Homologations |
|----------------|------------------------|-----------------------------------|--|---|--|---|--|------------------------------|
| KES.102 | LED | 12 V | Luce di posizione, indicatore di direzione, stop, luce targa, catarifrangente / Position light, turn signal, brake light, license plate light, reflector | lunghezza 12 m / 2,5 m tra fanali / 12 m + 2.5 m between lighting units | Spina 7 poli / 7-pin plug | Posteriore, con magnete / Rear, with magnetic mount | -20° / +50° C | ECE |

KIT LUCI POSTERIORI LED

REAR LIGHT LED SET
 KIT SIGNALISATION FEUX ARRIÈRE LED
 BELEUCHTUNGSSATZ
 JUEGO DE LUCES TRASERA LED



Articoli a ricambio

| | | |
|---|--------------|---|
|  | 02929 | Spina 7 poli 12-24V in plastica con chiusura a vite e cappuccio |
|  | 75275 | Fanale posteriore LED dx/sx 13,5V 105,6x36,4x 97,9 mm |

| Skù | Tipo luce / Light type | Tensione nominale / Rated voltage | Funzioni / Functions | Lunghezza cavo / Cable length | Collegamento elettrico / Electrical connection | Fissaggio / Fastening | Temperatura di esercizio / Operating temperature | Omologazioni / Homologations |
|--------------|------------------------|-----------------------------------|--|---|--|--|--|------------------------------|
| 60088 | LED | 12 V | Luce di posizione, indicatore di direzione, luce targa, stop, catarifrangente / Position light, turn signal, brake light, license plate light, reflector | lunghezza 7,5 m / 2,5 m tra fanali / 7.5 m + 2.5 m between lighting units | Spina 7 poli / 7-pin plug | Posteriore, con viti / Rear, with screw mounting | -20° C / +50° C | ECE |

KIT LUCI POSTERIORI LED

REAR LIGHT LED SET
 KIT SIGNALISATION FEUX ARRIÈRE LED
 BELEUCHTUNGSSATZ LED
 JUEGO DE LUCES TRASERA LED

Articoli a ricambio

| | | |
|--|--------------|--|
| | 00407 | Catarifrangente Ø 60 mm bianco con vite M5 |
| | 00426 | Catarifrangente triangolare rosso con viti |
| | 02929 | Spina 7 poli 12-24 V in plastica con chiusura a vite e cappuccio |
| | 76442 | Fanale posteriore LED dx/sx 12-24V Ø 140 mm. |

| Skù | Tipo luce / Light type | Tensione nominale / Rated voltage | Funzioni / Functions | Lunghezza cavo / Cable length | Collegamento elettrico / Electrical connection | Fissaggio / Fastening | Temperatura di esercizio / Operating temperature | Omologazioni / Homologations |
|--------------|------------------------|-----------------------------------|--|---|--|--|--|------------------------------|
| 76418 | LED | 12-24 V | Indicatore di direzione, luce di posizione, stop, catarifrangenti / Direction indicator, position light, brake light, reflectors | lunghezza 10 m + 4 m tra fanali / 10 m + 4 m between lighting units | Spina 7 poli / 7-pin plug | Posteriore, con viti / Rear, with screws | -40° C / +65° C | ECE |

KIT LUCI POSTERIORI LED 12/24V, 8 M+2,5 M

LED REAR LIGHT KIT 8 M+2,5 M
 KIT SIGNALISATION FEUX ARRIÈRE LED, 8 M+2,5 M
 BELEUCHTUNGSSATZ LED 8 M+2,5 M
 JUEGO DE LUCES TRASERA LED 8 M+2,5 M

Articoli a ricambio

| | | |
|--|--------------|--|
| | 77011 | Fanale posteriore LED 12-24V, lato sinistro, 245x40x151 mm |
| | 77012 | Fanale posteriore LED 12-24V, lato destro, 245x40x151 mm |
| | 02929 | Spina 7 poli 12-24 V in plastica con chiusura a vite e cappuccio |
| | 81219 | Luce targa a LED 10-30 V |

| Skù | Tipo luce / Light type | Tensione nominale / Rated voltage | Funzioni / Functions | Lunghezza cavo / Cable length | Collegamento elettrico / Electrical connection | Fissaggio / Fastening |
|--------------|------------------------|-----------------------------------|---|---|--|--|
| 76487 | LED | 12-24 V | Luce di posizione, indicatore di direzione, stop, luce targa, fendinebbia, retromarcia / Position light, direction indicator, stop light, license plate light, fog light, reverse light | lunghezza 8 m + 2,5 m tra fanali / 8 m + 2,5 m between lighting units | Spina 7 poli / 7-pin plug | posteriore, con viti / Rear, with screws |

KIT LUCI POSTERIORI LED CAVI CON CONNETTORI, 7,6 M + 2,5 M

LED REAR LIGHT KIT 12V, CABLES WITH CONNECTORS, 7.6 M + 2.5 M
 KIT FEUX ARRIÈRE LED 12V, CÂBLES AVEC CONNECTEURS, 7,6 M + 2,5 M
 LED-RÜCKLEUCHTENSET 12V, KABEL MIT STECKVERBINDERN, 7,6 M + 2,5 M
 KIT DE LUCES TRASERAS LED 12V, CABLES CON CONECTORES, 7,6 M + 2,5 M



1



2



3



4

Articoli a ricambio

| | | |
|--|-----------------|---|
| | 00407 | Catarifrangente Ø 60 mm bianco con vite M5 |
| | 01367 | Catarifrangente Ø 60 mm arancione con vite M5 |
| | 02929 | Spina 7 poli 12-24V in plastica con chiusura a vite e cappuccio |
| | 03426 | Kit magnetico per girofaro |
| | 75275 | Fanale posteriore LED dx/sx 13,5V 105,6x36,4x 97,9 mm |
| | DIS.2410 | Lamiera porta targa |

| Sku | Pos. | Tipo luce / Light type | Tensione nominale / Rated voltage | Funzioni / Functions | Lunghezza cavo / Cable length | Collegamento elettrico / Electrical connection | Fissaggio / Fastening |
|--------------|------|------------------------|-----------------------------------|--|---|--|---|
| 75994 | 1-2 | LED | 12 V | Luce di posizione, indicatore di direzione, stop, luce targa, catarifrangente / Position light, direction indicator, brake light, license plate light, reflector | lunghezza 7,6 m + 2,5 m tra fanali / 7.6 m + 2.5 m between lighting units | Spina 7 poli / 7-pin plug | Posteriore, con magnete / Rear, with magnet |
| 75995 | 3-4 | LED | 12 V | Luce di posizione, indicatore di direzione, stop, luce targa, catarifrangente / Position light, direction indicator, brake light, license plate light, reflector | lunghezza 7,6 m + 2,5 m tra fanali / 7.6 m + 2.5 m between lighting units | Spina 7 poli / 7-pin plug | Posteriore, con viti / Rear, with screws |

KIT LUCI POSTERIORI ALOGENE 12V

HALOGEN REAR LIGHT KIT 12V
 KIT FEUX ARRIÈRE HALOGÈNES 12V
 HALOGEN-RÜCKLEUCHTENSET 12V
 KIT DE LUCES TRASERAS HALÓGENAS 12V

1

2

3
Articoli a ricambio

| | | |
|--|-----------------|--|
| | 00440 | Lampadina alogena P21/5W 12V 21/5W BAY15d |
| | 00441 | Lampadina alogena P21 12V 21W BA15s |
| | 02929 | Spina 7 poli 12-24V in plastica con chiusura a vite e cappuccio |
| | 03426 | Kit magnetico per girofaro |
| | 55359 | Catarifrangente triangolare rosso 154x136 mm con fori |
| | 55368 | Fanale posteriore alogeno dx 100x95x50 mm |
| | 55369 | Fanale posteriore alogeno sx 100x95x50 mm |
| | DIS.2410 | Lamiera porta targa |

| SKU | Pos. | Tipo luce / Light type | Tensione nominale / Rated voltage | Lunghezza cavo / Cable length | Fissaggio / Fastening | Collegamento elettrico / Electrical connection | Contenuto / Content |
|--------------|------|------------------------|-----------------------------------|---|--|--|------------------------------------|
| 76443 | 1 | Alogeno / Halogen | 12 V | 7,5 m + 2,5 m tra fanali / 7.5 m + 2.5 m between lighting units | posteriore, con magneti / Rear, with magnets | Spina 7 poli / 7-pin plug | Lampadine incluse / Bulbs included |
| 76445 | 1 | Alogeno / Halogen | 12 V | 10 m + 4 m tra fanali / 10 m + 4 m between lighting units | posteriore, con magneti / Rear, with magnets | Spina 7 poli / 7-pin plug | Lampadine incluse / Bulbs included |
| 76446 | 2 | Alogeno / Halogen | 12 V | 7,5 m + 2,5 m tra fanali / 7.5 m + 2.5 m between lighting units | posteriore, con viti / Rear, with screws | Spina 7 poli / 7-pin plug | Lampadine incluse / Bulbs included |
| 76447 | 2 | Alogeno / Halogen | 12 V | 10 m + 4 m tra fanali / 10 m + 4 m between lighting units | posteriore, con viti / Rear, with screws | Spina 7 poli / 7-pin plug | Lampadine incluse / Bulbs included |
| 76448 | 3 | Alogeno / Halogen | 12 V | 7,5 m + 2,5 m tra fanali / 7.5 m + 2.5 m between lighting units | posteriore, con magneti / Rear, with magnets | Spina 7 poli / 7-pin plug | Lampadine incluse / Bulbs included |

KIT LUCI POSTERIORI ALOGENE

REAR LIGHT SET
KIT SIGNALISATION FEUX ARRIÈRE
BELEUCHTUNGSSATZ
JUEGO DE LUCES TRASERA



1



2

Articoli a ricambio

| | | |
|--|--------------|---|
| | 00397 | Lampadina alogena R5W 12V 5W BA15s |
| | 00407 | Catarifrangente Ø 60 mm bianco con vite M5 |
| | 00426 | Catarifrangente triangolare rosso con viti |
| | 00441 | Lampadina alogena P21 12V 21W BA15s |
| | 02817 | Fanale posteriore alogeno dx 160x71x70 mm |
| | 02818 | Fanale posteriore alogeno sx 160x71x70 mm |
| | 02929 | Spina 7 poli 12-24 V in plastica con chiusura a vite e cappuccio |

| Skü | Tipo luce / Light type | Tensione nominale / Rated voltage | Fissaggio / Fastening | Funzioni / Functions | Lunghezza cavo / Cable length | Collegamento elettrico / Electrical connection | Note / Notes |
|--------------|---------------------------|---|--|--|---|--|--|
| 02874 | Alogeno / Halogen | 12 V | Posteriore, con viti / Rear, with screws | Luce di posizione, indicatore di direzione, stop, luce targa / Position light, direction indicator, brake light, license plate light | lunghezza 7 m + 2,5 m tra fanali / 7 m + 2.5 m between lighting units | Spina 7 poli / 7-pin plug | Lampadine incluse / Bulbs included |

KIT LUCI POSTERIORI ALOGENE 12V CON STAFFE RIBALTABILI

HALOGEN REAR LIGHT KIT 12V WITH TILTING BRACKETS

KIT FEUX ARRIÈRE HALOGÈNES 12V AVEC SUPPORTS BASCULANTS

HALOGEN-RÜCKLEUCHTENSET 12V MIT KLAPPBAREN HALTERUNGEN

KIT DE LUCES TRASERAS HALÓGENAS 12V CON SOPORTES ABATIBLES

1

2

3

4

5

6
Articoli a ricambio

| | | |
|--|--------------|---|
| | 00407 | Catarifrangente Ø 60 mm bianco con vite M5 |
| | 00426 | Triangolo rifrangente rosso con viti |
| | 00440 | Lampadina alogena P21/5W 12V 21/5W BAY15d |
| | 00441 | Lampadina alogena P21 12V 21W BA15s |
| | 02929 | Spina 7 poli 12-24V in plastica con chiusura a vite e cappuccio |
| | 55359 | Catarifrangente triangolare rosso 154x136 mm con fori |
| | 55368 | Fanale posteriore alogeno dx 100x95x50 mm |
| | 55369 | Fanale posteriore alogeno sx 100x95x50 mm |

| Skù | Pos. | Tipo luce / Light type | Tensione nominale / Rated voltage | Funzioni / Functions | Lunghezza cavo / Cable length | Collegamento elettrico / Electrical connection | Fissaggio / Fastening |
|--------------|------|------------------------|-----------------------------------|--|---|--|---|
| 68608 | 1-2 | Alogeno / Halogen | 12V | Luce di posizione, indicatore di direzione, stop, luce targa / Position light, direction indicator, brake light, license plate light | 7,5 m + 2,5 m tra fanali / 7.5 m + 2.5 m between lighting units | Spina 7 poli / 7-pin plug | Staffe verticali ribaltabili a scatto / Vertical flip-up snap brackets |
| 68609 | 3-4 | Alogeno / Halogen | 12V | Luce di posizione, indicatore di direzione, stop, luce targa / Position light, direction indicator, brake light, license plate light | 7,5 m + 2,5 m tra fanali / 7.5 m + 2.5 m between lighting units | Spina 7 poli / 7-pin plug | Staffe orizzontali ribaltabili a scatto / Horizontal flip-up snap brackets |
| 68610 | 5-6 | Alogeno / Halogen | 12V | Luce di posizione, indicatore di direzione, stop, luce targa / Position light, direction indicator, brake light, license plate light | 7,5 m + 2,5 m tra fanali / 7.5 m + 2.5 m between lighting units | Spina 7 poli / 7-pin plug | Staffe orizzontali ribaltabili a molla / Horizontal flip-up spring brackets |

KIT LUCI ANTERIORI E POSTERIORI ALOGENE

REAR AND HEADLIGHT SET
 KIT SIGNALISATION FEUX ARRIÈRE ET FEU AVANT
 BELEUCHTUNGSSATZ
 JUEGO DE LUCES TRASERA Y DELANTERA



| Skü | Tipo luce / Light type | Tensione nominale / Rated voltage | Lunghezza cavo / Cable length | Collegamento elettrico / Electrical connection | Fissaggio / Fastening | Contenuto / Content |
|-------|------------------------|-----------------------------------|-------------------------------|--|--|---|
| 02910 | Alogeno / Halogen | 12 V | 4 m | Presä 7 poli / 7-pin socket | Posteriore, anteriore, con viti, staffe / Rear, front, with screws, brackets | Fanali posteriori e anteriori con lampadine, fusibile 7,5 A, fusibile 8 A, portafusibile, interruttore stop, presa 7 poli, piastra portapresa, blocchetto 6 vie, intermittenza 12 V, spia frecce, deviatore frecce e staffe / Front and rear lights with bulbs, 7.5 A fuse, 8 A fuse, fuse holder, brake switch, 7-pin socket, socket plate, 6-way connector, 12 V flasher, indicator warning light, indicator switch, and brackets |

KIT PANNELLI 423X423 MM OMOLOGATI TPESC / DIN 11030 CON FANALI POSTERIORI LED 12V

PANEL KIT 423X423 MM APPROVED TPESC/DIN 11030 WITH 12V LED REAR LIGHTS
 KIT PANNEAUX 423X423 MM HOMOLOGUÉS TPESC / DIN 11030 AVEC FEUX ARRIÈRE LED 12V
 TAFELSATZ 423X423 MM, ZUGELASSEN NACH TPESC / DIN 11030, MIT 12V LED-RÜCKLEUCHTEN
 KIT DE PANELES 423X423 MM HOMOLOGADOS TPESC / DIN 11030 CON LUCES TRASERAS LED 12V

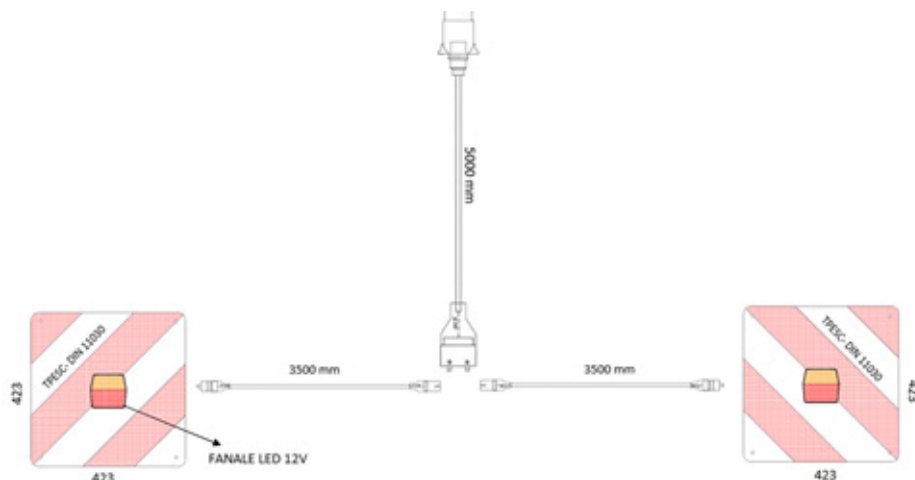

Articoli a ricambio

| | | |
|--|----------------|---|
| | 02929 | Spina 7 poli 12-24V in plastica con chiusura a vite e cappuccio |
| | 0F07296 | Fanale posteriore LED sx 12V, 99,7x30x92,7 mm |
| | 0F07297 | Fanale posteriore LED dx 12V, 99,7x30x92,7 mm |

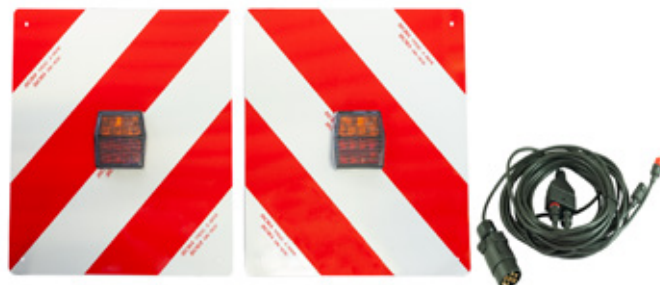

| Skü | Tipo luce / Light type | Tensione nominale / Rated voltage | Dimensioni / Dimensions | Funzioni / Functions | Contenuto / Content | Omologazioni Homologations | Note / Notes |
|-------|------------------------|-----------------------------------|-------------------------|--|--|----------------------------|---|
| 57823 | LED | 12 V | 423x423 | Luce di posizione, indicatore di direzione, luce stop e luce targa / Position light, direction indicator, brake light, and license plate light | 2 pannelli 423x423 mm retroriflettenti con fanali posteriori | ECE, TPESC, DIN 11030 | Lunghezza cavo 5 m + 7 m tra pannelli / Cable length 5 m + 7 m between panels |

BARRA LUCI LED 12V 1400÷ 2100 MM, CAVO 7,5 M

LIGHT BOARD LED 12V 1400÷ 2100 MM, 7,5 M CABLE
 RAMPE DE SIGNALISATION LED 12V 1400÷ 2100 MM, CÂBLE 7,5 M
 LEUCHTBALKEN LED 12V 1400÷ 2100 MM, 7,5M KABEL
 BARRA DE LUCES LED 12V 1400÷ 2100 MM, 7,5 M CABLE

Articoli a ricambio

| | | |
|--|--------------|---|
| | 02929 | Spina 7 poli 12-24V in plastica con chiusura a vite e cappuccio |
| | 02930 | Pres a 7 poli 12-24V in plastica |
| | 10370 | Triangolo rifrangente rosso con fori |
| | 75275 | Fanale posteriore LED dx/sx 13,5V 105,6x36,4x 97,9 mm |

| Sk u | Tipo luce / Light type | Tensione nominale / Rated voltage | Lunghezza minima / Min. length | Lunghezza massima / Max. length | Lunghezza cavo / Cable length | Funzioni / Functions | Collegamento elettrico / Electrical connection | Materiali / Material |
|--------------|------------------------|-----------------------------------|--------------------------------|---------------------------------|-------------------------------|--|--|-----------------------|
| 85459 | LED | 12 V | 1400 mm | 2100 mm | 7,5 m | Luce di posizione, stop, indicatore di direzione, luce targa / Position light, direction indicator, brake light, and license plate light | Spina 7 poli / 7-pin plug | Alluminio / Aluminium |

BARRA LUCI 12V 1400 ÷ 2100 MM, CAVO 7 M

LIGHT BOARD 12V 1400÷ 2100 MM, 7 M CABLE
 RAMPE DE SIGNALISATION 12V 1400÷ 2100 MM, CÂBLE 7 M
 LEUCHTBALKEN 12V 1400÷ 2100 MM, 7 M KABEL
 BARRA DE LUCES 12V 1400÷ 2100 MM, 7 M CABLE

Articoli a ricambio

| | | |
|--|--------------|--|
| | 00440 | Lampadina alogena P21/5W 12V 21/5W BAY15d |
| | 00441 | Lampadina alogena P21 12V 21W BA15s |
| | 02929 | Spina 7 poli 12-24 V in plastica con chiusura a vite e cappuccio |
| | 02930 | Pres a 7 poli 12-24 V in plastica |
| | 10370 | Catarifrangente triangolare rosso con fori |
| | 76433 | Fanale posteriore alogeno dx 105x50x97 mm |
| | 76434 | Fanale posteriore alogeno sx 105x50x97 mm |

| Sk u | Tipo luce / Light type | Tensione nominale / Rated voltage | Lunghezza minima / Min. length | Lunghezza massima / Max. length | Lunghezza cavo / Cable length | Funzioni / Functions | Collegamento elettrico / Electrical connection | Materiali / Material |
|--------------|------------------------|-----------------------------------|--------------------------------|---------------------------------|-------------------------------|--|--|-----------------------|
| 76444 | Alogeno / Halogen | 12 V | 1400 mm | 2100 mm | 7 m | Luce di posizione, stop, indicatore di direzione, luce targa / Position light, direction indicator, brake light, and license plate light | Spina 7 poli / 7-pin plug | Alluminio / Aluminium |

BARRA REGOLABILE 1200 ÷ 1800 MM CON FANALI POSTERIORI 12V

LIGHT BOARD WITH 12V REAR LIGHTS, 1200 ÷ 1800 MM
 RAMPE DE SIGNALISATION AVEC FEUX ARRIÈRE 12V, 1200 ÷ 1800 MM
 LEUCHTBALKEN MIT 12V RÜCKLEUCHTEN 1200 ÷ 1800 MM
 BARRA DE LUCES TRASERA



1



2

Articoli a ricambio

| | | |
|--|----------------|--|
| | 00426 | Catarifrangente triangolare rosso con viti |
| | 02921 | Spina 7 poli 12-24 V in plastica con chiusura a scatto |
| | 02929 | Spina 7 poli 12-24 V in plastica con chiusura a vite e cappuccio |
| | 0F07296 | Fanale posteriore LED sx 12V, 99,7x30x92,7 mm |
| | 0F07297 | Fanale posteriore LED dx 12V, 99,7x30x92,7 mm |
| | 55368 | Fanale posteriore alogeno dx 100x95x50 mm |
| | 55369 | Fanale posteriore alogeno sx 100x95x50 mm |

| Skü | Pos. | Tipo luce / Light type | Tensione nominale / Rated voltage | Lunghezza minima / Min. length | Lunghezza massima / Max. length | Lunghezza cavo / Cable length | Funzioni / Functions | Collegamento elettrico / Electrical connection | Materiali / Material |
|-------|------|------------------------|-----------------------------------|--------------------------------|---------------------------------|-------------------------------|--|---|-----------------------|
| 04899 | 1 | LED | 12 V | 1200 mm | 1800 mm | 7 m | Luce di posizione, stop, indicatore di direzione, luce targa / Position light, direction indicator, brake light, and license plate light | Spina 7 poli (non collegata al cavo) | Alluminio / Aluminium |
| 44859 | 2 | Alogeno / Halogen | 12 V | 1200 mm | 1800 mm | 7 m | Luce di posizione, Stop, Indicatore di direzione, Luce targa / Position light, direction indicator, brake light, and license plate light | Spina 7 poli (non collegata al cavo) / 7-pin plug | Alluminio / Aluminium |

BARRA LUCI 750 MM, CAVO 4,5 M

LIGHT BOARD 750 MM, 4,5 M CABLE
 RAMPE DE SIGNALISATION 750 MM, CÂBLE 4,5 M
 LEUCHTBALKEN 750 MM, 4,5M KABEL
 BARRA DE LUCES 750 MM, 4,5 M CABLE

Articoli a ricambio

| | | |
|--|--------------|---|
| | 55368 | Fanale posteriore alogeno dx 100x95x50 mm |
| | 02929 | Spina 7 poli 12-24 V in plastica con chiusura a vite e cappuccio |
| | 55369 | Fanale posteriore alogeno sx 100x95x50 mm |
| | 00440 | Lampadina alogena P21/5W 12V 21/5W BAY15d |
| | 00441 | Lampadina alogena P21 12V 21W BA15s |

| Skù | Tipo luce / Light type | Tensione nominale / Rated voltage | Lunghezza / Length | Lunghezza cavo / Cable length | Funzioni / Functions | Collegamento elettrico / Electrical connection | Materiali / Material | Note / Notes |
|--------------|---------------------------|--------------------------------------|-----------------------|----------------------------------|---|---|-------------------------|--|
| 44857 | Alogeno / Halogen | 12 V | 750 mm | 4,5 m | Luce di posizione, stop, indicatore di direzione, luce targa/ Position light, brake light, direction indicator, license plate light | Spina 7 poli / 7-pin plug | PVC | Lampadine incluse / Bulbs included. |

BARRA LUCI 1050 MM, CAVO 4,5 M

LIGHT BOARD 1050 MM, 4,5 M CABLE
 RAMPE DE SIGNALISATION 1050 MM, CÂBLE 4,5 M
 LEUCHTBALKEN 1050 MM, 4,5M KABEL
 BARRA DE LUCES 1050 MM, 4,5 M CABLE

Articoli a ricambio

| | | |
|--|--------------|---|
| | 02929 | Spina 7 poli 12-24 V in plastica con chiusura a vite e cappuccio |
| | 55369 | Fanale posteriore alogeno sx 100x95x50 mm |
| | 55359 | Catarifrangente triangolare rosso 154x136 mm con fori di fissaggio |
| | 00440 | Lampadina alogena P21/5W 12V 21/5W BAY15d |
| | 00441 | Lampadina alogena P21 12V 21W BA15s |

| Skù | Tipo luce / Light type | Tensione nominale / Rated voltage | Lunghezza cavo / Cable length | Funzioni / Functions | Collegamento elettrico / Electrical connection | Materiali / Material | Note / Notes |
|--------------|---------------------------|--------------------------------------|----------------------------------|---|---|-------------------------|---------------------------------------|
| 44863 | Alogeno / Halogen | 12 V | 4,5 m | Luce di posizione, stop, indicatore di direzione, luce targa/ Position light, brake light, direction indicator, license plate light | Spina 7 poli / 7-pin plug | PVC | Lampadine incluse / Bulbs included |

PARAURTI NON REGOLABILI CON FANALI LED 12V

FIXED LIGHT BOARDS WITH 12V LED REAR LIGHTS
 RAMPES DE SIGNALISATION FIXES AVEC FEUX ARRIÈRE LED 12V
 FESTE LEUCHTBALKEN MIT 12V LED-RÜCKLEUCHTEN
 BARRAS DE LUCES FIJAS CON LUCES TRASERAS LED 12V



Articoli a ricambio

| | | |
|--|--------------|--|
| | 02929 | Spina 7 poli 12-24 V in plastica con chiusura a vite e cappuccio |
| | 55268 | Fanale targa LED 12-24 V |
| | 84494 | Fanale posteriore LED dx 12V 243,6x48x148,5 mm |
| | 84495 | Fanale posteriore LED sx 12V 243,6x48x148,5 mm |

| SKU | Tipo luce / Light type | Tensione nominale / Rated voltage | Lunghezza / Length | Lunghezza cavo / Cable length | Funzioni / Functions | Collegamento elettrico / Electrical connection | Materiali / Material |
|---------------|------------------------|-----------------------------------|--------------------|-------------------------------|---|--|----------------------|
| 76991 | LED | 12 V | 1500 mm | 7,5 m | Luce di posizione, stop, indicatore di direzione, retromarcia, fendinebbia, luce targa / Position light, brake light, direction indicator, reverse light, rear fog light, license plate light | Spina 7 poli / 7-pin plug | Ferro / Steel |
| 76993 | LED | 12 V | 1600 mm | 7,5 m | Luce di posizione, stop, indicatore di direzione, retromarcia, fendinebbia, luce targa / Position light, brake light, direction indicator, reverse light, rear fog light, license plate light | Spina 7 poli / 7-pin plug | Ferro / Steel |
| 76995 | LED | 12 V | 1700 mm | 7,5 m | Luce di posizione, stop, indicatore di direzione, retromarcia, fendinebbia, luce targa / Position light, brake light, direction indicator, reverse light, rear fog light, license plate light | Spina 7 poli / 7-pin plug | Ferro / Steel |
| 76996L | LED | 12 V | 1800 mm | 7,5 m | Luce di posizione, stop, indicatore di direzione, retromarcia, fendinebbia, luce targa / Position light, brake light, direction indicator, reverse light, rear fog light, license plate light | Spina 7 poli / 7-pin plug | Ferro / Steel |
| 76998 | LED | 12 V | 2000 mm | 7,5 m | Luce di posizione, stop, indicatore di direzione, retromarcia, fendinebbia, luce targa / Position light, brake light, direction indicator, reverse light, rear fog light, license plate light | Spina 7 poli / 7-pin plug | Ferro / Steel |
| 77000 | LED | 12 V | 2200 mm | 7,5 m | Luce di posizione, stop, indicatore di direzione, retromarcia, fendinebbia, luce targa / Position light, brake light, direction indicator, reverse light, rear fog light, license plate light | Spina 7 poli / 7-pin plug | Ferro / Steel |

PARAURTI CON FANALI LED 12-24V

LIGHT BOARD LED 12-24V
 RAMPE DE SIGNALISATION LED 12-24V
 LEUCHTBALKEN LED 12-24V
 BARRA DE LUCES LED 12-24V

Articoli a ricambio

| | | |
|--|--------------|---|
| | 02929 | Spina 7 poli 12-24 V in plastica con chiusura a vite e cappuccio |
| | 55266 | Fanale posteriore LED dx 12-36V, 240x55x140 mm |
| | 55267 | Fanale posteriore LED sx 12-36V, 240x55x140 mm |
| | 55268 | Fanale targa LED 12-24 V |
| | 63102 | Luce ingombro DX LED 12-36V con luce anteriore, laterale e posteriore |
| | 63103 | Luce ingombro SX LED 12-36V con luce anteriore, laterale e posteriore |

| Skù | Tipo luce / Light type | Tensione nominale / Rated voltage | Lunghezza / Length | Lunghezza cavo / Cable length | Funzioni / Functions | Collegamento elettrico / Electrical connection | Materiali / Material |
|--------------|---------------------------|---|-----------------------|----------------------------------|---|---|--------------------------|
| 68600 | LED | 12-24 V | 1800 mm | 7 m | Luce di posizione, stop, indicatore di direzione, retromarcia, retronebbia, luce targa / Position light, brake light, direction indicator, reverse light, rear fog light, license plate light | Spina 7 poli / 7-pin plug | Alluminio / Aluminium |
| 68604 | LED | 12-24 V | 2000 mm | 7 m | Luce di posizione, stop, indicatore di direzione, retromarcia, retronebbia, luce targa / Position light, brake light, direction indicator, reverse light, rear fog light, license plate light | Spina 7 poli / 7-pin plug | Alluminio / Aluminium |

PARAURTI NON REGOLABILI CON FANALI ALOGENI 12V

FIXED LIGHT BOARDS WITH 12V HALOGEN REAR LIGHTS
 RAMPES DE SIGNALISATION FIXES AVEC FEUX ARRIÈRE HALOGÈNES 12V
 FESTE LEUCHTBALKEN MIT 12V HALOGEN-RÜCKLEUCHTEN
 BARRAS DE LUCES FIJAS CON LUCES TRASERAS HALÓGENAS 12V



Articoli a ricambio

| | | |
|--|--------------|--|
| | 00277 | Lampadina alogena 12V 5W C5W SV8.5-8 11x39 |
| | 00440 | Lampadina alogena P21/5W 12V 21/5W BAY15d |
| | 00441 | Lampadina alogena P21 12V 21W BA15s |
| | 02929 | Spina 7 poli 12-24 V in plastica con chiusura a vite e cappuccio |
| | 55395 | Fanale posteriore alogeno dx 12V 246X63x149 mm |
| | 55396 | Fanale posteriore alogeno sinistro 120V 246x63x149 mm |

| Skù | Tipo luce / Light type | Tensione nominale / Rated voltage | Lunghezza / Length | Lunghezza cavo / Cable length | Funzioni / Functions | Collegamento elettrico / Electrical connection | Materiali / Material | Note / Notes |
|--------------|------------------------|-----------------------------------|--------------------|-------------------------------|---|--|----------------------|------------------------------------|
| 76990 | Alogeno / Halogen | 12 V | 1500 mm | 7,5 m | Luce di posizione, stop, indicatore di direzione, retromarcia, retronebbia, luce targa / Position light, brake light, direction indicator, reverse light, rear fog light, license plate light | Spina 7 poli / 7-pin plug | Ferro / Steel | Lampadine incluse / Bulbs included |
| 76992 | Alogeno / Halogen | 12 V | 1600 mm | 7,5 m | Luce di posizione, stop, indicatore di direzione, retromarcia, retronebbia, luce targa / Position light, brake light, direction indicator, reverse light, rear fog light, license plate light | Spina 7 poli / 7-pin plug | Ferro / Steel | Lampadine incluse / Bulbs included |
| 76994 | Alogeno / Halogen | 12 V | 1700 mm | 7,5 m | Luce di posizione, stop, indicatore di direzione, retromarcia, retronebbia, luce targa / Position light, brake light, direction indicator, reverse light, rear fog light, license plate light | Spina 7 poli / 7-pin plug | Ferro / Steel | Lampadine incluse / Bulbs included |
| 76996 | Alogeno / Halogen | 12 V | 1800 mm | 7,5 m | Luce di posizione, stop, indicatore di direzione, retromarcia, retronebbia, luce targa / Position light, brake light, direction indicator, reverse light, rear fog light, license plate light | Spina 7 poli / 7-pin plug | Ferro / Steel | Lampadine incluse / Bulbs included |
| 76997 | Alogeno / Halogen | 12 V | 2000 mm | 7,5 m | Luce di posizione, stop, indicatore di direzione, retromarcia, retronebbia, luce targa / Position light, brake light, direction indicator, reverse light, rear fog light, license plate light | Spina 7 poli / 7-pin plug | Ferro / Steel | Lampadine incluse / Bulbs included |
| 76999 | Alogeno / Halogen | 12 V | 2200 mm | 7,5 m | Luce di posizione, stop, indicatore di direzione, retromarcia, retronebbia, luce targa / Position light, brake light, direction indicator, reverse light, rear fog light, license plate light | Spina 7 poli / 7-pin plug | Ferro / Steel | Lampadine incluse / Bulbs included |

PARAURTI CON FANALI ALOGENI 12V

LIGHT BOARD 12V
 RAMPE DE SIGNALISATION 12V
 LEUCHTBALKEN 12V
 BARRA DE LUCES 12V

1

2
Articoli a ricambio

| | | | |
|--|---------------|---|--------|
| | 00405 | Fanale targa | |
| | 02929 | Spina 7 poli 12-24V in plastica con chiusura a vite e cappuccio | |
| | 76477D | Fanale posteriore alogeno dx 237x58,6x135,5 mm | |
| | 76477S | Fanale posteriore alogeno sx 237x58,6x135,5 mm | |
| | 76485 | Lente a ricambio | 76477D |
| | 76486 | Lente a ricambio | 76477S |

| Skù | Pos. | Tipo luce / Light type | Tensione nominale / Rated voltage | Lunghezza / Length | Lunghezza cavo / Cable length | Funzioni / Functions | Collegamento elettrico / Electrical connection | Materiali / Material | Note / Notes |
|--------------|------|---------------------------|---|-----------------------|---|--|--|--------------------------|---|
| 68602 | 1 | Alogeno / Halogen | 12 V | 1800 mm | 7 m / Cable length 0,5m + extension cable 7m | Luce di posizione, stop, indicatore di direzione, retromarcia, retronebbia, luce targa / Position lamp, stop lamp, direction indicator, reversing lamp, rear fog lamp, number plate lamp | Spina 7 poli / 7-pin plug | Alluminio / Aluminium | Paraurto sottoposto a verniciatura per cataforesi anti-corrosione. / Board painted by cathaphoresis process anticorrosion |
| 68603 | 2 | Alogeno / Halogen | 12 V | 1800 mm | 7 m / Cable length 0,5m + extension cable 7m | Luce di posizione, stop, indicatore di direzione, retromarcia, retronebbia, luce targa / Position lamp, stop lamp, direction indicator, reversing lamp, rear fog lamp, number plate lamp | Spina 7 poli / 7-pin plug | Alluminio / Aluminium | Paraurto sottoposto a verniciatura per cataforesi anti-corrosione. / Board painted by cathaphoresis process anticorrosion |
| 68606 | 1 | Alogeno / Halogen | 12 V | 2000 mm | 7 m / Cable length 0,5m + extension cable 7m | Luce di posizione, stop, indicatore di direzione, retromarcia, retronebbia, luce targa / Position lamp, stop lamp, direction indicator, reversing lamp, rear fog lamp, number plate lamp | Spina 7 poli / 7-pin plug | Alluminio / Aluminium | Paraurto sottoposto a verniciatura per cataforesi anti-corrosione. / Board painted by cathaphoresis process anticorrosion |

SET STAFFE

REAR MOUNT BRACKET SET
 JEU DE SUPPORTS DE MONTAGE ARRIÈRE
 HINTERE HALTERUNG
 JUEGO DE SOPORTES TRASEROS



| Sku | Descrizione / Description | Interasse fori / Hole spacing |
|-------|---------------------------|--|
| 02428 | Staffa a L / L-bracket | 58 mm per montaggio fanale / 58 mm for lamp mounting |

SET STAFFE RIBALTABILI

TILTING BRACKET SET
 JEU DE SUPPORTS RABATTABLES
 KLAPPHALTERUNGEN
 JUEGO DE SOPORTES TRASEROS ABATIBLES

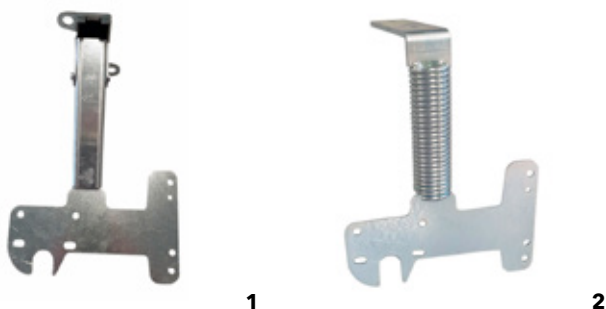

| Sku | Pos. | Lato / Side | Modello / Model | Materiali / Material |
|-------|------|-------------|--------------------------------------|--------------------------------------|
| 55391 | 1 | Dx / Rh | ribaltabile a scatto / Snap flip-up | Zincata argento / Silver zinc-plated |
| 55392 | 1 | Sx / Lh | ribaltabile a scatto / Snap flip-up | Zincata argento / Silver zinc-plated |
| 55393 | 2 | Dx / Rh | ribaltabile a molla / Spring flip-up | Zincata argento / Silver zinc-plated |
| 55394 | 2 | Sx / Lh | ribaltabile a molla / Spring flip-up | Zincata argento / Silver zinc-plated |



Pannelli e catadiottri

Warning panels and reflectors

I prodotti recanti il marchio AMA qui indicati sono realizzati da AMA S.p.A. e destinati a essere utilizzati come ricambi adattabili e non originali. I riferimenti a marchi, codici originali e costruttori di terzi, riportati in corrispondenza degli articoli AMA compatibili, hanno esclusivamente la finalità di identificare il modello, l'applicazione o la destinazione d'uso del prodotto, in conformità a quanto previsto dal Regolamento (CE) n. 1400/2002 e dalla normativa vigente in materia di concorrenza e uso lecito dei marchi di terzi. / The products bearing the AMA brand name listed here are manufactured by AMA S.p.A. and are intended for use as adaptable, non-original spare parts. References to trademarks, original codes and third-party manufacturers, shown alongside compatible AMA items, are intended solely to identify the model, application or intended use of the product, in accordance with Regulation (EC) No. 1400/2002 and current legislation on competition and the lawful use of third-party trademarks.

PANNELLI IN ALLUMINIO PER SEGNALAZIONE DELLE ATTREZZATURE AGRICOLE - OMOLOGAZIONE EUROPEA

ALUMINIUM PANELS FOR AGRICULTURAL EQUIPMENT WARNING - EUROPEAN HOMOLOGATION
 PANNEAUX EN ALUMINIUM POUR LA SIGNALISATION DES ÉQUIPEMENTS AGRICOLES - HOMOLOGATION EUROPÉENNE
 ALUMINIUM-WARNTAFELN FÜR LANDWIRTSCHAFTLICHE GERÄTE - EUROPESE HOMOLOGATIE
 PANELES DE ALUMINIO PARA SEÑALIZACIÓN DE EQUIPOS AGRÍCOLAS - HOMOLOGACIÓN EUROPEA







Omologazioni per la circolazione stradale in tutti i paesi europei. Conforme al regolamento ECE 70, Classe 5 - Rif. Regolamento Europeo ECE 86 (MOTHER REG. 2015/208) / *Approved for road use in all European countries. Compliant with ECE Regulation 70, Class 5 - Ref. European Regulation ECE 86 (MOTHER REG. 2015/208)*

| Skü | Linea / Line | Dimensioni / Dimensions | Materiali / Material | Fissaggio / Fastening | Note / Notes |
|--------------|---------------------------------|-------------------------|-----------------------|---|---|
| 55343 | Pannello singolo / Single panel | 282x282 mm | Alluminio / Aluminium | Con viti (non incluse) / With screws (not included) | Con angoli arrotondati / With rounded corners |
| 55344 | Kit da 2 pannelli / 2-panel kit | 282x282 mm | Alluminio / Aluminium | Con viti (non incluse) / With screws (not included) | Con angoli arrotondati / With rounded corners |
| 60096 | Kit da 2 pannelli / 2-panel kit | 423x423 mm | Alluminio / Aluminium | Con viti (non incluse) / With screws (not included) | Con angoli arrotondati / With rounded corners |
| 55443 | Kit da 2 pannelli / 2-panel kit | 423x282 mm | Alluminio / Aluminium | Con viti (non incluse) / With screws (not included) | Con angoli arrotondati / With rounded corners |

KIT PANNELLI ADESIVI PER SEGNALAZIONE DELLE ATTREZZATURE AGRICOLE, OMOLOGAZIONE EUROPEA

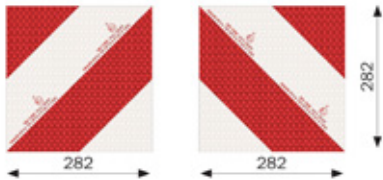
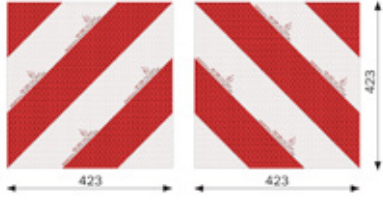
ADHESIVE PANEL KIT APPROVED FOR MARKING AGRICULTURAL EQUIPMENT, EUROPEAN HOMOLOGATION
 KIT PANNEAUX ADHÉSIFS POUR LA SIGNALISATION DES ÉQUIPEMENTS AGRICOLES, HOMOLOGATION EUROPÉENNE
 KIT MIT SELBSTKLEBENDEN TAFELN, EUROPESE HOMOLOGATIE
 KIT DE PANELES ADHESIVOS HOMOLOGADOS PARA SEÑALIZAR EQUIPOS AGRÍCOLAS, HOMOLOGACIÓN EUROPEA

Omologazioni per la circolazione stradale in tutti i paesi europei. Conforme al regolamento R104, Classe F - Rif. Regolamento Europeo ECE 86 (MOTHER REG. 2015/208) / *Approved for road use in all European countries. Compliant with Regulation R104, Class F - Ref. European Regulation ECE 86 (MOTHER REG. 2015/208)*

| Skü | Linea / Line | Dimensioni / Dimensions | Fissaggio / Fastening |
|--------------|---|-------------------------|-----------------------|
| 55345 |  | 282x282 | Adesivo / Adhesive |
| 55346 |  | 423x423 | Adesivo / Adhesive |
| 55347 |  | 423x282 | Adesivo / Adhesive |
| 55348 |  | 846x141 | Adesivo / Adhesive |
| 55349 |  | 423x141 | Adesivo / Adhesive |

PANNELLO IN ALLUMINIO PER SEGNALAZIONE ATTREZZATURE AGRICOLE 423X423 - ITALIA

ALUMINIUM WARNING PANEL FOR AGRICULTURAL EQUIPMENT 423X423 - ITALY
 PANNEAU EN ALUMINIUM POUR SIGNALISATION DES ÉQUIPEMENTS AGRICOLES 423X423 - ITALIE
 ALUMINIUM-WARNTAFEL FÜR LANDWIRTSCHAFTLICHE GERÄTE 423X423 - ITALIEN
 PANEL DE ALUMINIO PARA SEÑALIZACIÓN DE EQUIPOS AGRÍCOLAS 423X423 - ITALIA



Omologato per la circolazione stradale italiana / *Approved for use on Italian roads*

| Skü | Dimensioni / Dimensions | Materiali / Material | Fissaggio / Fastening | Note / Notes |
|-------------------------------|-------------------------|-----------------------|---|---|
| 04030 Pannello singolo | 423x423 | Alluminio / Aluminium | Con viti (non incluse), la scritta TOP del pannello deve sempre risultare sul lato più alto / With screws (not included) - "TOP" marking must face upward | Con angoli arrotondati / With rounded corners |

KIT 2 PANNELLI IN ALLUMINIO PER SEGNALAZIONE DELLE ATTREZZATURE AGRICOLE 564X282 - ITALIA

KIT WITH 2 ALUMINIUM PANELS FOR AGRICULTURAL EQUIPMENT 564X282 - ITALY
 KIT DE 2 PANNEAUX EN ALUMINIUM POUR LA SIGNALISATION DES ÉQUIPEMENTS AGRICOLES 564X282 - ITALIE
 SATZ MIT 2 ALUMINIUM-WARNTAFELN FÜR LANDWIRTSCHAFTLICHE GERÄTE 564X282 - ITALIEN
 KIT DE 2 PANELES DE ALUMINIO PARA SEÑALIZACIÓN DE EQUIPOS AGRÍCOLAS 564X282 - ITALIA

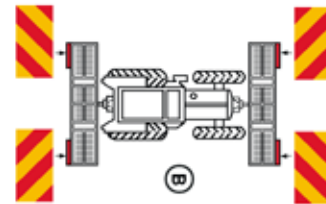
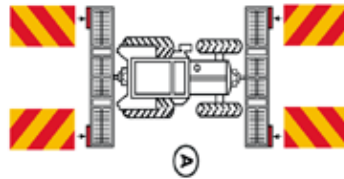

Omologato per la circolazione stradale italiana / *Approved for use on Italian roads*

| Skü | Linea / Line | Dimensioni / Dimensions | Materiali / Material | Fissaggio / Fastening | Note / Notes |
|---|--------------|-------------------------|-----------------------|---|---|
| 04031 Kit 2 pannelli / 2-panel kit | | 564x282 | Alluminio / Aluminium | Con viti (non incluse), la scritta TOP del pannello deve sempre risultare sul lato più alto / With screws (not included) - "TOP" marking must face upward | Con angoli arrotondati / With rounded corners |

PANNELLO IN ALLUMINIO PER SEGNALAZIONE CARICHI SPORGENTI 500X500 - ITALIA

ALUMINIUM PANEL FOR OVERHANGING LOAD 500X500 - ITALY
 PANNEAU EN ALUMINIUM POUR LA SIGNALISATION DE CHARGES DÉBORDANTES 500X500 - ITALIE
 ALUMINIUM-WARNTAFEL FÜR ÜBERSTEHENDE LADUNG 500X500 - ITALIEN
 PANEL DE ALUMINIO PARA SEÑALIZACIÓN DE CARGAS SOBRESALIENTES 500X500 - ITALIA

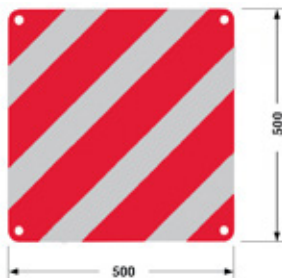

Omologato per la circolazione stradale italiana / *Approved for use on Italian roads*

| Skü | Linea / Line | Dimensioni / Dimensions | Interasse fori / Hole spacing | Materiali / Material | Fissaggio / Fastening | Note / Notes |
|--|--------------|-------------------------|-------------------------------|-----------------------|--|---|
| 04034 Pannello singolo / Single panel | | 500x500 | 456 | Alluminio / Aluminium | Con viti (non incluse) per 4 fori rivettati ø 9 mm / Panel with 4 riveted holes and rounded corners ø 9 mm | Con angoli arrotondati / With rounded corners |

KIT 2 PANNELLI IN ALLUMINIO PER RIMORCHIO CON PORTATA \geq 3500 KG - ITALIA

KIT WITH 2 ALUMINIUM PANELS FOR TRAILER WITH CAPACITY \geq 3500 KG - ITALY
 KIT DE 2 PANNEAUX EN ALUMINIUM POUR REMORQUE AVEC CAPACITÉ \geq 3500 KG - ITALIE
 SATZ MIT 2 ALUMINIUM-WARNTAFELN FÜR ANHÄNGER MIT EINER TRAGFÄHIGKEIT \geq 3500 KG - ITALIEN
 KIT DE 2 PANELES DE ALUMINIO PARA REMOLQUE CON CAPACIDAD \geq 3500 KG - ITALIA

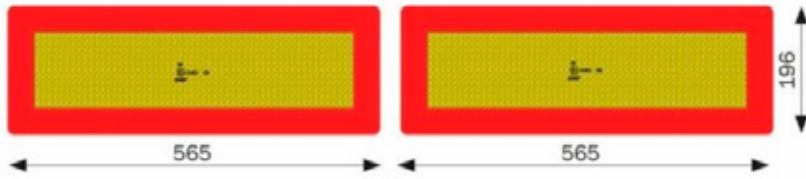

Omologato per la circolazione stradale italiana / Approved for use on Italian roads

| Sku | Linea / Line | Dimensioni / Dimensions | Materiali / Material | Fissaggio / Fastening | Note / Notes |
|-------|------------------------------|-------------------------|-----------------------|---|---|
| 04065 | Kit 2 pannelli / 2-panel kit | 565x196 / 562x196 | Alluminio / Aluminium | Con viti (non include) / With screws (not included) | Con angoli arrotondati / With rounded corners |

KIT 2 PANNELLI AUTOCARRO E MOTRICE PORTATA \geq 3500 KG

KIT OF 2 PANELS FOR TRUCK AND TRACTOR UNIT PAYLOAD \geq 3500 KG
 KIT DE 2 PANNEAUX POUR CAMION ET TRACTEUR ROUTIER, CHARGE UTILE \geq 3500 KG
 SATZ MIT 2 TAFELN FÜR LKW UND ZUGMASCHINE, NUTZLAST \geq 3500 KG
 KIT DE 2 PANELES PARA CAMIÓN Y CABEZA TRACTORA, CARGA ÚTIL \geq 3500 KG

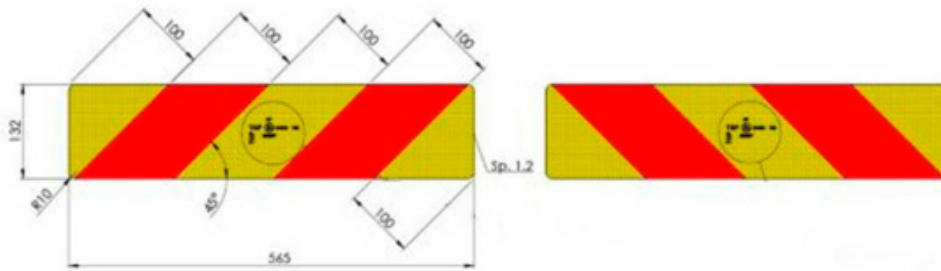

Omologato per la circolazione stradale italiana / Approved for use on Italian roads

| Sku | Linea / Line | Dimensioni / Dimensions | Materiali / Material | Fissaggio / Fastening | Note / Notes |
|-------|------------------------------|-------------------------|-----------------------|---|---|
| 59791 | Kit 2 pannelli / 2-panel kit | 565x132 | Alluminio / Aluminium | Con viti (non include) / With screws (not included) | Con angoli arrotondati / With rounded corners |

KIT 2 PANNELLI IN ALLUMINIO PER SEGNALARE LE ATTREZZATURE AGRIC. 423X282 - FRANCIA E GERMANIA

KIT WITH 2 ALU PANELS FOR AGRICULTURAL EQUIPMENT 423X282 - FR. AND GERMANY
 KIT DE 2 PANNEAUX EN ALU PR LA SIGNAL. DES ÉQUIP. AGRIC. 423X282 - FR. ET ALL.
 SATZ MIT 2 ALU-WARNTAFELN FÜR LANDWIRTSCHAFTLICHE GERÄTE 423X282 - FRANKREICH UND DEUTSCHLAND
 KIT DE 2 PANELES DE ALUMINIO PARA SEÑALIZACIÓN DE EQUIPOS AGRÍCOLAS 423X282 - FRANCIA Y ALEMANIA

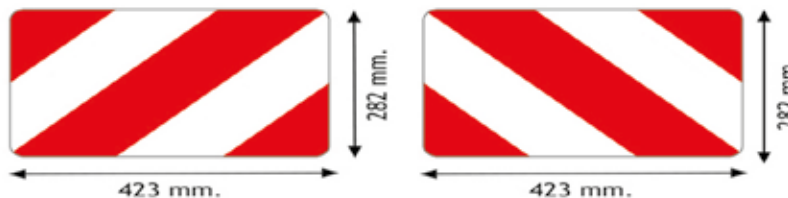

Omologazione per la circolazione stradale tedesca DIN 11030 e francese TP ESC / Approved for road use in Germany (DIN 11030) and France (TP ESC)

| Sku | Linea / Line | Dimensioni / Dimensions | Materiali / Material | Fissaggio / Fastening | Note / Notes |
|-------|------------------------------|-------------------------|-----------------------|---|---|
| 57818 | Kit 2 pannelli / 2-panel kit | 423x282 | Alluminio / Aluminium | Con viti (non include) / With screws (not included) | Con angoli arrotondati / With rounded corners |

KIT 2 PANNELLI PER SEGNALARE LE ATTREZZATURE AGRIC. 423X423 FORI RIVETTATI - FRANCIA E GERMANIA

KIT WITH 2 ALU PANELS FOR AGRICULTURAL EQUIPMENT WARNING 423X423 WITH RIVETED HOLES - FR/DE
 KIT DE 2 PANNEAUX EN ALU PR LA SIGNAL. DES ÉQUIP. AGRIC. 423X423 AV. TROUS RIVETÉS - FR. ET ALL.
 SATZ MIT 2 ALU-WARNTAFELN FÜR LANDWIRTSCHAFTLICHE GERÄTE 423X423 MIT GENIETETEM LOCH - FRANKREICH UN
 KIT DE 2 PANELES DE ALUMINIO PARA SEÑALIZACIÓN DE EQUIPOS AGRÍCOLAS 423X423 CON AGUJEROS REMACHADOS

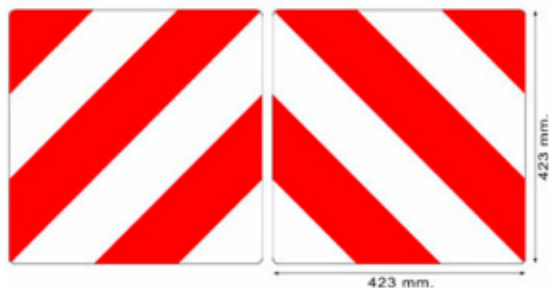

Omologazione per la circolazione stradale tedesca DIN 11030 e francese TP ESC / *Approved for road use in Germany (DIN 11030) and France (TP ESC)*

| Skü | Linea / Line | Dimensioni / Dimensions | Materiali / Material | Fissaggio / Fastening | Note / Notes |
|--------------|------------------------------|-------------------------|-----------------------|--|---|
| 60089 | Kit 2 pannelli / 2-panel kit | 423x423 | Alluminio / Aluminium | Con viti (non include) per 4 fori rivettati ø 9 mm / With screws (not included) for 4 riveted holes ø 9 mm | Con angoli arrotondati / With rounded corners |

PANNELLI IN ALLUMINIO DI SEGNALAZIONE DELLE ATTREZZATURE AGRICOLE 423X423 - FRANCIA E GERMANIA

ALUMINIUM WARNING PANELS FOR AGRICULTURAL EQUIPMENT 423X423 - FRANCE AND GERMANY
 PANNEAUX EN ALUMINIUM DE SIGNALISATION DES ÉQUIPEMENTS AGRICOLES 423X423 - FRANCE ET ALLEMAGNE
 ALUMINIUM-WARNTAFELN FÜR LANDWIRTSCHAFTLICHE GERÄTE 423X423 - FRANKREICH UND DEUTSCHLAND
 PANELES DE ALUMINIO DE SEÑALIZACIÓN PARA EQUIPOS AGRÍCOLAS 423X423 - FRANCIA Y ALEMANIA



Omologazione per la circolazione stradale tedesca DIN 11030 e francese TP ESC / *Approved for road use in Germany (DIN 11030) and France (TP ESC)*

| Skü | Linea / Line | Dimensioni / Dimensions | Materiali / Material | Fissaggio / Fastening | Note / Notes |
|--------------|---------------------------------|-------------------------|-----------------------|--|---|
| 57821 | Pannello singolo / Single panel | 423x423 | Alluminio / Aluminium | Lato destro, con viti (non include) / Right side, with screws (not included) | Con angoli arrotondati / With rounded corners |
| 57822 | Pannello singolo / Single panel | 423x423 | Alluminio / Aluminium | Lato sinistro, con viti (non include) / Lh side, with screws (not included) | Con angoli arrotondati / With rounded corners |

KIT 2 PANNELLI IN FERRO ZINCATO PER SEGNALAZIONE DELLE ATTREZZATURE AGRIC. 564X282 - GERMANIA

KIT WITH 2 GALVANIZED STEEL PANELS FOR AGRICULTURAL EQUIPMENT WARNING 564X282 - GERMANY
 KIT DE 2 PANNEAUX EN ACIER GALVANISÉ PR LA SIGNAL. DES ÉQUIP. AGRIC. 564X282 - ALL.
 SATZ MIT 2 VERZINKTEN STAHL-WARNTAFELN FÜR LANDWIRTSCHAFTLICHE GERÄTE 564X282 - DEUTSCHLAND
 KIT DE 2 PANELES DE ACERO GALVANIZADO PARA SEÑALIZACIÓN DE EQUIPOS AGRÍCOLAS 564X282 - ALEMANIA

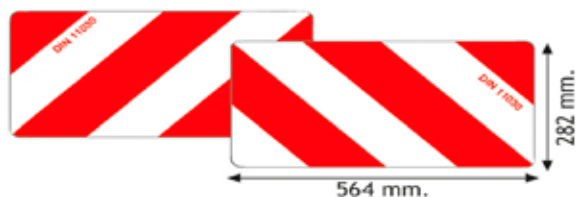

Omologazione per la circolazione stradale tedesca DIN 11030 / *Approved for road use in Germany (DIN 11030)*

| Skü | Linea / Line | Dimensioni / Dimensions | Materiali / Material | Fissaggio / Fastening | Note / Notes |
|--------------|------------------------------|-------------------------|-----------------------------|---|---|
| 57817 | Kit 2 pannelli / 2-panel kit | 564x282 | Ferro zincato / Zinc plated | Con viti (non include) / With screws (not included) | Con angoli arrotondati / With rounded corners |

TRIANGOLO VEICOLO FERMO

WARNING TRIANGLE FOR BROKEN-DOWN VEHICLE
 TRIANGLE DE SIGNALISATION POUR VÉHICULE EN PANNE
 WARNDREIECK FÜR PANNENFAHRZEUG
 TRIÁNGULO DE SEÑALIZACIÓN PARA VEHÍCULO AVERIADO



| Skü | Lunghezza / Length | Altezza / Height | Materiali / Material | Confezionamento / Packaging |
|-------|--------------------|------------------|--|-----------------------------|
| 04035 | 46 cm | 40,50 cm | Base a croce, in ferro / Iron cross base | Astuccio / Case |

TRIANGOLO VEICOLI LENTI E RELATIVI RIMORCHI

HAZARD TRIANGLE SLOW TRAFFIC LRV
 TRIANGLE DE DANGER LRV À CIRCULATION LENTE
 GEFAHRENDREIECK LANGSAMVERKEHR LRV
 TRIÁNGULO DE PELIGRO TRÁFICO LENTO LRV

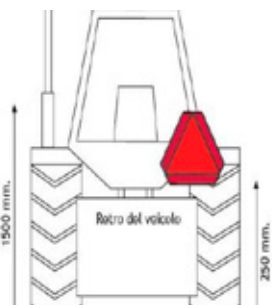

Omologazioni per la circolazione stradale in tutti i paesi europei. Conforme al regolamento ECE 69.01 / *Approved for road use in all European countries. Compliant with ECE Regulation 69.01*

| Skü | Linea / Line | Dimensioni / Dimensions | Materiali / Material | Fissaggio / Fastening |
|-------|---------------------------------|-------------------------|-----------------------|---|
| 12439 | Pannello singolo / Single panel | 365x365 | Alluminio / Aluminium | Con viti (non incluse), parte posteriore del veicolo / To ensure stable mounting, use 2 appropriate screws to fix the triangle to the vehicle surface |

NASTRO RIFLETTE PER SUPERFICI RIGIDE

REFLECTIVE TAPE - CONTOUR MARKER
 BANDEROLE RÉFLECTORISÉE
 MARKIERUNGSBAND REFLEKTIEREND
 BANDEROLA REFLECTANTE

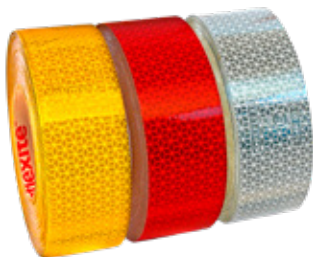

| Skü | Colore / Colour | Lunghezza / Length | Larghezza / Width | Note / Notes |
|-------|-----------------|--------------------|-------------------|---|
| 57857 | Giallo / Yellow | 50 m | 50 mm | Omologato conforme al regolamento ECE ONU 104 ed ECE 48 / ECE R104 and ECE R48 approved |
| 57858 | Bianco / White | 50 m | 50 mm | Omologato conforme al regolamento ECE ONU 104 ed ECE 48 / ECE R104 and ECE R48 approved |
| 57859 | Rosso / Red | 50 m | 50 mm | Omologato conforme al regolamento ECE ONU 104 ed ECE 48 / ECE R104 and ECE R48 approved |

SEGNALE LIMITE DI VELOCITÀ - ITALIA

VEHICLE SPEED LIMIT - ITALY
 PANNEAU DE LIMITATION DE VITESSE - ITALIE
 GESCHWINDIGKEITSBEGRENZUNGSSCHILD - ITALIEN
 SEÑAL DE LIMITACIÓN DE VELOCIDAD - ITALIA

Omologato per la circolazione stradale italiana / *Approved for use on Italian roads*

| Skü | img. | Velocità massima / Max. speed | Materiali / Material | Diametro / Diameter |
|-------|------|-------------------------------|-------------------------|---------------------|
| 04023 | | 40 km/h | Alluminio / Aluminium | 200 mm |
| 04033 | | 40 km/h | Adesivo / Self-adhesive | 200 mm |
| 59108 | | 70 km/h | Adesivo / Self-adhesive | 200 mm |
| 59109 | | 80 km/h | Adesivo / Self-adhesive | 200 mm |

PORTATARGA CON CERNIERA

NUMBERPLATE HOLDER WITH HINGE
 PORTE PLAQUE AVEC CHARNIERE
 NUMMERSCHILDHALTER MIT SCHARNIER
 NÚMERO PORTA PLACA CON BISAGRA

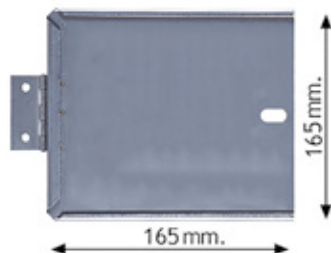

| Skü | Dimensioni / Dimensions | Materiali / Material | Note / Notes |
|-------|-------------------------|------------------------|---------------------------|
| 55318 | 165x165 mm | Inox / Stainless steel | con cerniera / with hinge |

LAMIERA PORTATARGA

LICENSE PLATE BRACKET
SUPPORT DE PLAQUE EN TÔLE
NUMMERSCHILDHALTER AUS BLECH
SOPORTE DE PLACA DE CHAPA



| Skü | Materiali / Material | Dimensioni / Dimensions |
|----------|-----------------------|-------------------------|
| DIS.2410 | lamiera / Metal sheet | 250x165 |

TARGA RIPETITRICE BIFACCIALE PER RIMORCHI AGRICOLI

DOUBLE-SIDED NUMBER PLATE FOR AGRICULTURAL TRAILERS
PLAQUE DOUBLE FACE DE SIGNALISATION POUR REMORQUE AGRICOLE
DOPPELSEITIGES NUMMERSCHILD FÜR LANDWIRTSCHAFTLICHE ANHÄNGER
TARGA REPETIDOR BIFACCIALE PARA REMOLQUES AGRÍCOLAS

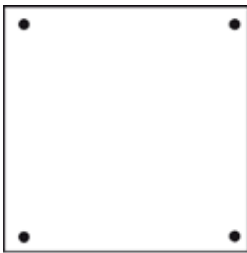

Lato bianco
White side

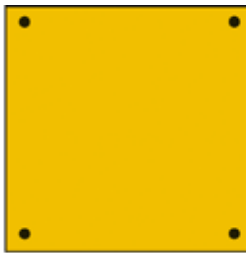

Lato giallo
Yellow side

| Skü | Linea / Line | Colore / Colour | Dimensioni / Dimensions | Materiali / Material | Note / Notes |
|-------|------------------------------|---------------------------------------|-------------------------|--------------------------|---|
| 09250 | bifacciale / Double-sided | Bianco e Giallo / White and yellow | 165x165 mm | Alluminio / Aluminium | La targa ripetitrice omologata deve essere obbligatoriamente richiesta in Motorizzazione, quelle che esistono in commercio sono targhe ripetitrici provvisorie, ossia in attesa di quella definitiva. / The approved doubleside number plate must be compulsorily requested in the Motorization, those that exist on the market are temporary repeater plates, that is, pending the definitive one. |

NUMERI E LETTERE ADESIVI PER TARGHE RIPETITRICI

ADHESIVE NUMBERS AND LETTERS FOR LICENSE PLATES

CHIFFRES ET LETTRES ADHÉSIFS POUR PLAQUES D'IMMATRICULATION

SELBSTKLEBENDE ZAHLEN UND BUCHSTABEN FÜR NUMMERNSCHILDNER

NÚMEROS Y LETRAS ADHESIVOS PARA PLACAS

| Skü | | Skü | | Skü | | Skü | |
|-------|--|-------|--|-------|--|-------|--|
| 09251 | | 09261 | | 09271 | | 09281 | |
| 09252 | | 09262 | | 09272 | | 37346 | |
| 09253 | | 09263 | | 09273 | | 37347 | |
| 09254 | | 09264 | | 09274 | | 37348 | |
| 09255 | | 09265 | | 09275 | | 37349 | |
| 09256 | | 09266 | | 09276 | | | |
| 09257 | | 09267 | | 09277 | | | |
| 09258 | | 09268 | | 09278 | | | |
| 09259 | | 09269 | | 09279 | | | |
| 09260 | | 09270 | | 09280 | | | |

KIT NUMERI E LETTERE ADESIVI PER TARGA RIPETITRICE

ADHESIVE NUMBERS AND LETTERS KIT FOR REPEATER PLATE
 KIT DE CHIFFRES ET LETTRES ADHÉSIFS POUR PLAQUE RÉPÉTITRICE
 KIT MIT SELBSTKLEBENDEN ZAHLEN UND BUCHSTABEN FÜR WIEDERHOLUNGSKENNZEICHEN
 KIT DE NÚMEROS Y LETRAS ADHESIVAS PARA PLACA REPETIDORA

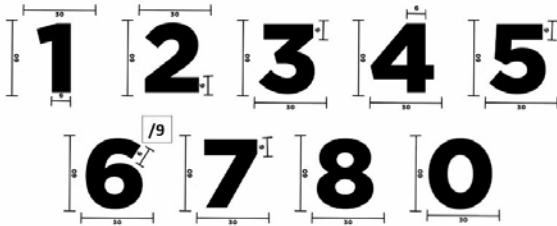

1

10pz x Numero

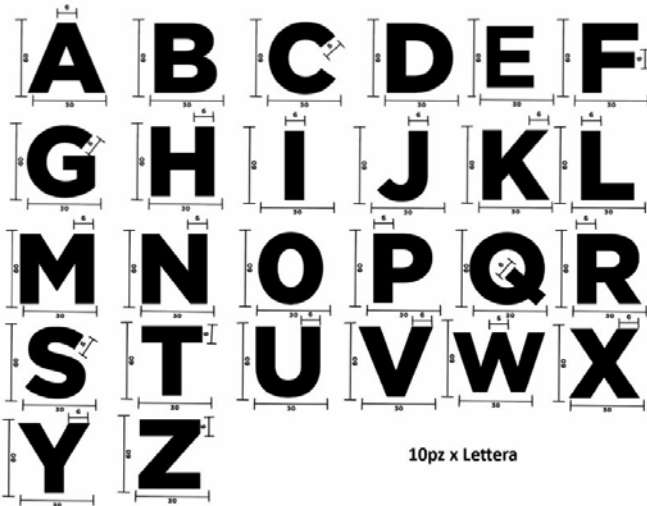

10pz x Lettera

2

| Skü | Pos. | Contenuto / Content | Fissaggio / Fastening | Dimensioni / Dimensions |
|-------|------|--|-------------------------|-------------------------|
| 55555 | 1 | Numeri: 0,1,2,3,4,5,6/9,7,8 | adesivo / Self-adhesive | 30x60 mm |
| 55556 | 2 | Lettere: A,B,C,D,E,F,G,H,I,J,K,L,M,N,O,P,Q,R,S,T,U,V,W,X,Y,Z | adesivo / Self-adhesive | 30x60 mm |

CATARIFRANGENTI TRIANGOLARI

TRIANGULAR REFLECTORS
 CATADIOPTRÉS TRIANGULAIRES
 DREIECKIGE RÜCKSTRAHLER
 REFLECTORES TRIANGULARES

| Skü | img. | Colore / Colour | Fissaggio / Fastening | Dimensioni / Dimensions | Interasse fori / Hole spacing | Materiali / Material |
|-------|------|-----------------|---------------------------------------|-------------------------|-------------------------------|----------------------|
| 44426 | | rosso / red | Prigioniero M5x16 mm / M5x16 mm screw | 160x140 mm | 85 mm | PMMA |
| 10370 | | Rosso / Red | Fori M5 / M5 holes | 155 x137 mm | 70 mm | Metacrilato/ Acrylic |
| 55359 | | Rosso / Red | Fori M5 / M5 holes | 154x136 mm | 69,5 mm | ABS |
| 64441 | | Rosso / Red | Adesivo / Self-adhesive | 120x135 mm | | Metacrilato/ Acrylic |

CATARIFRANGENTI ROTONDI

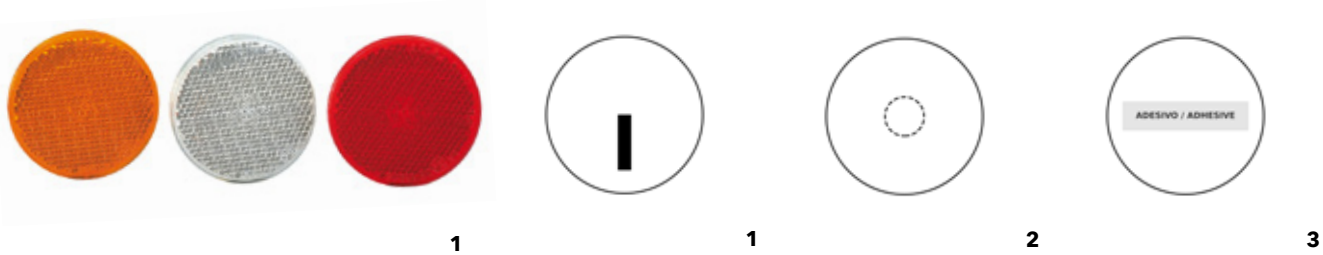
 ROUND REFLECTORS
 CATADIOPTRES RONDS
 RUNDE RÜCKSTRAHLER
 REFLECTORES REDONDOS

| Sku | Pos. | Colore / Colour | Fissaggio / Fastening | Diametro / Diameter |
|-------|-------|--------------------|------------------------------------|---------------------|
| 00407 | 1 / 1 | Bianco / White | Prigioniero M5 / M5 screw | 60 mm |
| 00408 | 1 / 1 | Rosso / Red | Prigioniero M5 / M5 screw | 60 mm |
| 00410 | 1 / 1 | Rosso / Red | Prigioniero M5 / M5 screw | 80 mm |
| 00476 | 1 / 1 | Bianco / White | Prigioniero M5 / M5 screw | 80 mm |
| 00477 | 1 / 1 | Arancione / Orange | Prigioniero M5 / M5 screw | 80 mm |
| 01367 | 1 / 1 | Arancione / Orange | Prigioniero M5 / M5 screw | 60 mm |
| 01649 | 1 / 3 | Bianco / White | Adesivo / Self-adhesive | 60 mm |
| 01650 | 1 / 3 | Arancione / Orange | Adesivo / Self-adhesive | 60 mm |
| 01651 | 1 / 3 | Rosso / Red | Adesivo / Self-adhesive | 60 mm |
| 04410 | 1 / 1 | Rosso / Red | Prigioniero M6 / M6 screw | 85 mm |
| 04476 | 1 / 1 | Bianco / White | Prigioniero M6 / M6 screw | 85 mm |
| 04477 | 1 / 1 | Arancione / Orange | Prigioniero M6 / M6 screw | 85 mm |
| 10371 | 1 / 2 | Bianco / White | Con foro 5,5 mm / With 5.5 mm hole | 60 mm |
| 10372 | 1 / 2 | Arancione / Orange | Con foro 5,5 mm / With 5.5 mm hole | 60 mm |
| 10373 | 1 / 2 | Rosso / Red | Con foro 5,5 mm / With 5.5 mm hole | 60 mm |









CATARIFRANGENTI RETTANGOLARI CON VITE

 RECTANGULAR REFLECTORS WITH SCREW
 CATADIOPTRES RECTANGULAIRES AVEC VIS
 RECHTECKIGER RÜCKSTRAHLER MIT SCHRAUBE
 REFLECTORES RECTANGULARES CON TORNILLO

| Sku | Colore / Colour | Fissaggio / Fastening | Dimensioni / Dimensions | Interasse fori / Hole spacing | Materiali / Material |
|-------|--------------------|---|-------------------------|-------------------------------|-------------------------|
| 06113 | Rosso / Red | con 2 prigionieri M6 / with 2 stud bolt | 95,5x58,5 mm | 45 mm | Metalcrlilato / Acrylic |
| 69302 | Arancione / Orange | con 2 prigionieri M6 / with 2 stud bolt | 95,5x58,5 mm | 45 mm | Metalcrlilato / Acrylic |

CATARIFRANGENTI RETTANGOLARI

RECTANGULAR REFLECTORS
CATADIOPTRES RECTANGULAIRES
RECHTECKIGER RÜCKSTRAHLER
REFLECTORES RECTANGULARES

| Skü | img. | Colore / Colour | Fissaggio / Fastening | Dimensioni / Dimensions | Interasse fori / Hole spacing | Materiali / Material |
|-------|---|--------------------|--------------------------------|-------------------------|-------------------------------|-----------------------|
| 03917 |  | Bianco / White | Adesivo / Self-adhesive | 57x39 mm | | Metacrilato / Acrylic |
| 03918 |  | Arancione / Orange | Adesivo / Self-adhesive | 57x39 mm | | Metacrilato / Acrylic |
| 03919 |  | Rosso / Red | Adesivo / Self-adhesive | 57x39 mm | | Metacrilato / Acrylic |
| 33920 |  | Bianco / white | Adesivo / Self-adhesive | 106x7,5x50 mm | | PMMA |
| 33921 |  | Arancione / amber | Adesivo / Self-adhesive | 106x7,5x50 mm | | PMMA |
| 33922 |  | rosso / red | Adesivo / Self-adhesive | 106x7,5x50 mm | | PMMA |
| 19735 |  | Rosso / Red | 2 fori ø 4 mm / 2 holes Ø 4 mm | 107x51 mm | 90 mm | Metacrilato / Acrylic |
| 19736 |  | Arancione / Orange | 2 fori ø 4 mm / 2 holes Ø 4 mm | 107x51 mm | 90 mm | Metacrilato / Acrylic |





Prese e spine

Sockets and plugs

I prodotti recanti il marchio AMA qui indicati sono realizzati da AMA S.p.A. e destinati a essere utilizzati come ricambi adattabili e non originali. I riferimenti a marchi, codici originali e costruttori di terzi, riportati in corrispondenza degli articoli AMA compatibili, hanno esclusivamente la finalità di identificare il modello, l'applicazione o la destinazione d'uso del prodotto, in conformità a quanto previsto dal Regolamento (CE) n. 1400/2002 e dalla normativa vigente in materia di concorrenza e uso lecito dei marchi di terzi. / The products bearing the AMA brand name listed here are manufactured by AMA S.p.A. and are intended for use as adaptable, non-original spare parts. References to trademarks, original codes and third-party manufacturers, shown alongside compatible AMA items, are intended solely to identify the model, application or intended use of the product, in accordance with Regulation (EC) No. 1400/2002 and current legislation on competition and the lawful use of third-party trademarks.

PRESE UNIPOLARI

SOCKETS 1 PIN
PRISE 1 PÔLES
STECKDOSE 1-POLIG
TOMAS DE 1 POLOS

| Skü | Tensione nominale / Rated voltage | Modello / Model | Terminali / Terminals | Note / Notes |
|--|-----------------------------------|-------------------------|---|----------------------------|
| 02947  | 12-24 V | Unipolare / Single-pole | A faston piatto 6,3 mm / Flat faston 6.3 mm | |
| 02949  | 12-24 V | Unipolare / Single-pole | A faston piatto 6,3 mm / Flat faston 6.3 mm | Con coperchio / With cover |

PRESE BIPOLARI

SOCKETS 2 PIN
PRISE 2 PÔLES
STECKDOSE 2-POLIG
TOMAS DE 2 POLOS

| Skü | Tensione nominale / Rated voltage | Modello / Model | Terminali / Terminals | Note / Notes |
|---|-----------------------------------|------------------------|---|----------------------------|
| 02924  | 12-24 V | Bipolare / Double-pole | A faston piatto 6,3 mm / Flat faston 6.3 mm | Con coperchio / With cover |
| 02948  | 12-24 V | Bipolare / Double-pole | A faston piatto 6,3 mm / Flat faston 6.3 mm | |
| 02984  | 12-24 V | Bipolare / Double-pole | A faston piatto 6,3 mm / Flat faston 6.3 mm | Con coperchio / With cover |
| 22926  | 12-24V | Bipolare / Double-pole | A vite / Screw | |
| 55442  | 12 V | Bipolare / Double-pole | A vite / Screw | Con coperchio / With cover |
| P19010  | 12-24 V | Bipolare / Double-pole | A faston piatto 6,3 mm / Flat faston 6.3 mm | Con coperchio / With cover |





PRESE 2 POLI

 SOCKETS 2 PIN
 PRISE 2 PÔLES
 STECKDOSE 2-POLIG
 TOMAS DE 2 POLOS

| Skü | Tensione nominale / Rated voltage | Terminali / Terminals | Note / Notes |
|--|-----------------------------------|---|----------------------------|
|  02928 | 12-24 V | A faston piatto 6,3 mm / Flat faston 6.3 mm | Con coperchio / With cover |

PRESE 3 POLI

 SOCKETS 3 PIN
 PRISE 3 PÔLES
 STECKDOSE 3-POLIG
 TOMAS DE 3 POLOS

| Skü | Tensione nominale / Rated voltage | Modello / Model | Terminali / Terminals | Materiali / Material | Note / Notes |
|--|-----------------------------------|-----------------|---|----------------------|----------------------------|
|  16524 | 12-24 V | 3 poli / 3-pole | A faston piatto 6,3 mm / Flat faston 6.3 mm | Plastica / Plastic | Con coperchio / With cover |
|  19036 | 12-24 V | 3 poli / 3-pole | A faston piatto 6,3 mm / Flat faston 6.3 mm | Plastica / Plastic | Con coperchio / With cover |
|  26957 | 12-24 V | 3 poli / 3-pole | A faston piatto 6,3 mm / Flat faston 6.3 mm | Plastica / Plastic | Con coperchio / With cover |
|  60237 | 12-24 V | 3 poli / 3-pole | A faston piatto 6,3 mm / Flat faston 6.3 mm | Plastica / Plastic | Con coperchio / With cover |

PRESE 4 POLI

 SOCKETS 4 PIN
 PRISE 4 PÔLES
 STECKDOSE 4-POLIG
 TOMAS DE 4 POLOS





| Skü | Tensione nominale / Rated voltage | Modello / Model | Terminali / Terminals | Note / Notes |
|--|-----------------------------------|-----------------|--------------------------|----------------------------|
|  84428 | 12-24 V | 4 poli / 4-pole | A serrafilo / Wire clamp | Con coperchio / With cover |

PRESE 7 POLI

SOCKETS 7 PIN
PRISE 7 PÔLES
STECKDOSE 7-POLIG
TOMAS DE 7 POLOS

Articoli a ricambio

| | | | |
|---|---------------|--|-------------------|
|  | 03967 | Staffa per il fissaggio delle prese a 7 vie | 02930,06501 |
|  | 04491 | Guarnizione posteriore in gomma per presa a 7 poli, con attacchi serrafilo | 02930,06501,37352 |
|  | F22080 | Blocchetto per presa 7 poli a faston | 37342,37352 |
|  | P19007 | Guarnizione posteriore alta per prese 7 poli a faston | 37342,37352 |

| Skù | img. | Tensione nominale / Rated voltage | Modello / Model | Terminali / Terminals | Note / Notes |
|--------------|---|-----------------------------------|-----------------|---|----------------------------|
| 02930 |  | 12-24 V | 7 poli / 7-pole | A serrafilo / Wire clamp | Con coperchio / With cover |
| 37352 |  | 12-24 V | 7 poli / 7-pole | A faston piatto 6,3 mm / Flat faston 6.3 mm | Con coperchio / With cover |
| 06501 |  | 12-24 V | 7 poli / 7-pole | A serrafilo / Wire clamp | Con coperchio / With cover |
| 12580 |  | 12-24 V | 7 poli / 7-pole | A serrafilo / Wire clamp | Con coperchio / With cover |

PRESE 13 POLI

SOCKETS 13 PIN
PRISE 13 PÔLES
STECKDOSE 13-POLIG
TOMAS DE 13 POLOS

| Skù | Tensione nominale / Rated voltage | Modello / Model | Terminali / Terminals | Note / Notes | |
|--------------|---|-----------------|-----------------------|--------------------------|----------------------------|
| 51691 |  | 12-24 V | 13 poli / 13-pole | A serrafilo / Wire clamp | Con coperchio / With cover |





SPINE 2 POLI

PLUG 2 PIN
FICHE 2 PÔLES
STECKER 2-POLIG
ENCHUFE DE 2 POLOS

| Skü | Tensione nominale / Rated voltage | Modello / Model | Terminali / Terminals | Materiali / Material | Certificazioni / Certifications |
|---|-----------------------------------|-----------------|---|----------------------------|---------------------------------|
| 02927  | 12-24 V | 2 poli / 2-pole | A faston piatto 6,3 mm / Flat faston 6.3 mm | Plastica / Plastic housing | CE, RoHS |

SPINE 3 POLI

PLUG 3 PIN
FICHE 3 PÔLES
STECKER 3-POLIG
ENCHUFE DE 3 POLOS

| Skü | Tensione nominale / Rated voltage | Modello / Model | Terminali / Terminals | Materiali / Material | Note / Notes |
|---|-----------------------------------|-----------------|---|----------------------|--------------------------|
| 16525  | 12-24 V | 3 poli / 3-pole | A faston piatto 6,3 mm / Flat faston 6.3 mm | Plastica / Plastic | |
| 19035  | 12-24 V | 3 poli / 3-pole | A faston piatto 6,3 mm / Flat faston 6.3 mm | Plastica / Plastic | Con cappuccio / With cap |
| 19037  | 12-24 V | 3 poli / 3-pole | A faston piatto 6,3 mm / Flat faston 6.3 mm | Plastica / Plastic | Con cappuccio / With cap |
| 19057  | 12-24 V | 3 poli / 3-pole | A faston piatto 6,3 mm / Flat faston 6.3 mm | Plastica / Plastic | Con cappuccio / With cap |



SPINE 4 POLI

PLUG 4 PIN
FICHE 4 PÔLES
STECKER 4-POLIG
ENCHUFE DE 4 POLOS

| Skü | Tensione nominale / Rated voltage | Modello / Model | Terminali / Terminals |
|---|-----------------------------------|-----------------|--------------------------|
| 84427  | 12-24 V | 4 poli / 4-pole | A serrafilo / Wire clamp |

SPINE 7 POLI

PLUG 7 PIN
FICHE 7 PÔLES
STECKER 7-POLIG
ENCHUFE DE 7 POLOS

| Skü | Tensione nominale / Rated voltage | Modello / Model | Terminali / Terminals |
|---|-----------------------------------|-----------------|--------------------------|
|  02921 | 12-24 V | 7 poli / 7-pole | A serrafilo / Wire clamp |
|  02929 | 12-24 V | 7 poli / 7-pole | A serrafilo / Wire clamp |
|  06502 | 12-24 V | 7 poli / 7-pole | A serrafilo / Wire clamp |



SPINE 13 POLI

PLUG 13 PIN
FICHE 13 PÔLES
STECKER 13-POLIG
ENCHUFE DE 13 POLOS

| Skü | Tensione nominale / Rated voltage | Modello / Model | Terminali / Terminals |
|---|-----------------------------------|-------------------|--------------------------|
|  51690 | 12-24 V | 13 poli / 13-pole | A serrafilo / Wire clamp |

ADATTATORE

ADAPTOR
ADAPTATEUR
ADAPTER
ADAPTADOR

| Skü | Tensione nominale / Rated voltage | Modello / Model | Terminali / Terminals | Note / Notes |
|---|-----------------------------------|---|--------------------------|----------------------------|
|  36771 | 12-24 V | spina 7/ presa 13 poli / 7-pole plug / 13-pole socket | A serrafilo / Wire clamp | Con coperchio / With cover |
|  51689 | 12-24 V | spina 13/ presa 7 poli / 13-pole plug / 7-pole socket | A serrafilo / Wire clamp | Con coperchio / With cover |

PRESE E SPINE ISOBUS

 ISOBUS SOCKETS AND PLUGS
 PRISES ET FICHES ISOBUS
 ISOBUS-STECKDOSEN UND -STECKER
 ENCHUFES Y TOMAS ISOBUS

| Skü | Tensione nominale / Rated voltage | Modello / Model | Linea / Line | Colore / Colour | Note / Notes |
|-------|-----------------------------------|-----------------|--------------|-----------------|----------------------------|
| 68152 | 12 V | 9 poli / 9-pole | Active | Nero / Black | Con coperchio / With cover |
| 68153 | 12 V | 9 poli / 9-pole | Passive | Grigio / Grey | Con coperchio / With cover |
| 68154 | 12 V | 9 poli / 9-pole | IBBC | Nero / Black | |
| 68155 | 12 V | 4 poli / 4-pole | IBBC | Giallo / Yellow | |

PRESE USB

 USB SOCKET
 PRISE USB
 STECKDOSE USB
 ENCHUFE USB

| Skü | Tensione nominale / Rated voltage | Modello / Model | Attacco / Attachment | Note / Notes |
|--------|-----------------------------------|---|-----------------------------------|----------------------------|
| 57179 | Input: 12V; Output 5V | USB Tipo A e C / USB Type-A and Type-C output | Terminali 6,3 mm / Faston 6,3 mm | Con coperchio / With cover |
| F24166 | Input: 12V; Output: 5V | USB tipo A / USB type A | Cavo 600 mm / Cable length 600 mm | Con coperchio / With cover |

PRESA ACCENDISIGARI

 CIGARETTE SOCKET
 FICHE POUR ALLUME-CIGARE
 STECKER FÜR ZIGARETTENANZÜNDER
 ENCHUFE PARA ENCENDEDOR CIGARILLO

| Skü | Tensione nominale / Rated voltage | Modello / Model | Note / Notes |
|-------|-----------------------------------|------------------------|----------------------------|
| 64473 | 12 V | Bipolare / Double-pole | Con coperchio / With cover |



PRESA USB

USB CHARGER
CHARGEUR USB
USB-LADEGERÄT
CARGADOR USB

| Skü | Modello / Model | Tensione nominale / Rated voltage |
|--------------|--|-----------------------------------|
| 77008 |  Presa da parete e porta USB-A / Wall charger plug and USB-A port | Input 100-240V, output 5V |



PROLUNGHE

EXTENSION CABLE
CÄBLE DE RALLONGE
VERLÄNGERUNGSKABEL
CABLE ALARGADOR

| Skü | img. | Tipo / Type | Tensione nominale / Rated voltage | Lunghezza / Length |
|--------------|---|--|-----------------------------------|--------------------|
| 04490 |  | cavo spiralato con spine 7 poli / Coiled cable with 7-pole plugs | 12-24 V | 3,50 m |
| 12645 |  | prolunga con spine 7 poli / Extension cable with 7-pole plugs | 12-24 V | 3000 mm |
| 12646 |  | prolunga con presa e spina 7 poli / Extension with 7-pin socket and plug | 12-24 V | 3000 mm |

PROLUNGA ELETTRICA CON PRESA MULTIPLA

POWER CABLE WITH MULTIPLE SOCKETS
CÄBLE D'ALIMENTATION AVEC PRISE MULTIPLE
STROMKABEL MIT MEHRFACHSTECKDOSE
CABLE DE ALIMENTACIÓN CON TOMA MÜLTIPLE

| Skü | img. | Tipo / Type | Tensione nominale / Rated voltage | Lunghezza / Length |
|--------------|---|---|-----------------------------------|--------------------|
| 55460 |  | Prolunga con doppia presa 3 poli / Extension cable with dual 3-pin socket | 12 V | 4500 mm |
| 55461 |  | Prolunga con doppia presa 3 poli / Extension cable with dual 3-pin socket | 12 V | 200 mm |



Intermittenze, centraline e relays

Flashers, control units, relays

I prodotti recanti il marchio AMA qui indicati sono realizzati da AMA S.p.A. e destinati a essere utilizzati come ricambi adattabili e non originali. I riferimenti a marchi, codici originali e costruttori di terzi, riportati in corrispondenza degli articoli AMA compatibili, hanno esclusivamente la finalità di identificare il modello, l'applicazione o la destinazione d'uso del prodotto, in conformità a quanto previsto dal Regolamento (CE) n. 1400/2002 e dalla normativa vigente in materia di concorrenza e uso lecito dei marchi di terzi. / The products bearing the AMA brand name listed here are manufactured by AMA S.p.A. and are intended for use as adaptable, non-original spare parts. References to trademarks, original codes and third-party manufacturers, shown alongside compatible AMA items, are intended solely to identify the model, application or intended use of the product, in accordance with Regulation (EC) No. 1400/2002 and current legislation on competition and the lawful use of third-party trademarks.

CENTRALINE PRERISCALDO CANDELETTE E ARRESTO MOTORE

GLOW PLUG PREHEATING CONTROL UNITS AND ENGINE SHUTDOWN UNITS
 UNITÉS DE CONTRÔLE DE PRÉCHAUFFAGE DES BOUGIES ET UNITÉS D'ARRÊT MOTEUR
 GLÜHKERZEN-VORHEIZSTEUERGERÄTE UND MOTORABSCHALTSTEUERGERÄTE
 UNIDADES DE CONTROL DE PRECALENTAMIENTO DE BUJÍAS Y UNIDADES DE PARADA DEL MOTOR



| Skü | Tipo / Type | Prodotti compatibili / Compatible products |
|-------|-------------|--|
| 63755 | 12V | 12591 |
| 63756 | 24V | 12591 |

CENTRALINE PRERISCALDO CANDELETTE PER MOTORI LOMBARDINI

GLOW PLUG PREHEATING CONTROL UNITS FOR LOMBARDINI ENGINES
 UNITÉS DE CONTRÔLE DE PRÉCHAUFFAGE DES BOUGIES POUR MOTEURS LOMBARDINI
 GLÜHKERZEN-VORHEIZSTEUERGERÄTE FÜR LOMBARDINI-MOTOREN
 UNIDADES DE CONTROL DE PRECALENTAMIENTO DE BUJÍAS PARA MOTORES LOMBARDINI



| Skü | Tensione nominale / Rated voltage | Prodotti compatibili / Compatible products |
|-------|-----------------------------------|--|
| 09179 | 12V | 57689 |

LAMPEGGIATORE LED ELETTRONICO 12V 4 PIN PER FANALI A LED

ELECTRONIC LED FLASHER 12V 4 PIN FOR LED LIGHTS
 CLIGNOTANT LED ÉLECTRONIQUE 12V 4 BROCHES POUR FEUX LED
 ELEKTRONISCHER LED-BLINKER 12V 4 PINS FÜR LED-SCHINWERFER
 INTERMITENTE LED ELECTRÓNICO 12V 4 PINES PARA FAROS LED



| Skü | Modello / Model | Tensione nominale / Rated voltage | Prodotti compatibili / Compatible products |
|-------|----------------------------------|-----------------------------------|--|
| 57809 | per luci a LED / Fore LED lights | 12V | 64581 |

LAMPEGGIATORE LED ELETTRONICO 4 PIN PER FANALI A LED E ALOGENI

ELECTRONIC LED FLASHER 4 PIN FOR LED AND HALOGEN LIGHTS
 CLIGNOTANT LED ÉLECTRONIQUE 4 BROCHES POUR FEUX LED ET HALOGÈNES
 ELEKTRONISCHER LED-BLINKER 4 PINS FÜR LED- UND HALOGEN-SCHWEINWERFER
 INTERMITENTE LED ELECTRÓNICO 4 PINES PARA FAROS LED Y HALÓGENOS



| Skü | Tensione nominale / Rated voltage | Potenza nominale / Rated power | Modello / Model | Note / Notes | Prodotti compatibili / Compatible products |
|--------------|--------------------------------------|-----------------------------------|------------------------------------|---|---|
| 63662 | 12 V | 120 W | Con spia / With indicator light | Funziona sia con lampade alogene che con lampade a led indipendenti o collegate senza variazione di frequenza. / Work with halogen lamps and also with independent or intercalated led lamps without changing frequency | 64581 |
| 63663 | 24 V | 240 W | Con spia / With indicator light | Funziona sia con lampade alogene che con lampade a led indipendenti o collegate senza variazione di frequenza. / Work with halogen lamps and also with independent or intercalated led lamps without changing frequency | 64581 |

INTERMITTENZE 3 PIN

FLASHER UNIT 3 PIN
 UNITÉ CLIGNOTANTE 3 BROCHE
 BLINKGEBER 3 PINS
 UNIDAD INTERMITENTE 3 PINES

1

2

| Skü | Pos. | Tensione nominale / Rated voltage | Potenza nominale / Rated power | Modello / Model | Prodotti compatibili / Compatible products |
|---------------|------|-----------------------------------|--------------------------------|---------------------------------|--|
| 00707 | 1 | 12 V | 47-180 W | Con spia / With indicator light | 64581 |
| 118013 | 2 | 24 V | 47-180 W | Con spia / With indicator light | 64581 |

INTERMITTENZA 6 POLI 12V CON SPIA E STAFFA

FLASHER UNIT 12V 6-POLE WITH INDICATOR LIGHT AND BRACKET
 UNITÉ CLIGNOTANTE 6 BROCHES 12V AVEC VOYANTS ET SUPPORT
 6-POLIGER 12V BLINKGEBER MIT KONTROLLLEUCHE UND HALTERUNG
 UNIDAD INTERMITENTE 6 PINES 12V CON LUZ INDICADORA Y SOPORTE



| Skü | Tensione nominale / Rated voltage | Potenza nominale / Rated power | Modello / Model | Prodotti compatibili / Compatible products |
|--------------|-----------------------------------|---|---------------------------------|--|
| 00708 | 12 V | Corrente nominale 2+1+1x21 + 5 W 8x21 W | Con spia / With indicator light | 12589 |

INTERMITTENZA 12V 4 POLI

FLASHER UNIT 12V 4-POLE
UNITÉ CLIGNOTANTE 12V 4 BROCHES
4-POLIGER BLINKGEBER 12V
UNIDAD INTERMITENTE 12V 4 PINES



| Sku | Tensione nominale / Rated voltage | Potenza nominale / Rated power | Modello / Model | Terminali / Terminals | Prodotti compatibili / Compatible products |
|---------------|-----------------------------------|--------------------------------|---------------------------------|---------------------------|--|
| I18082 | 12 V | 4X21+2 W | con spia / With indicator light | 4 Terminali / 4 Terminals | 64581 |

RELÈ 12V 30-40A CON DIODO

RELAY 12V 30-40A WITH DIODE
RELAIS 12V 30-40A AVEC DIODE
12V 30-40A RELAIS MIT DIODE
RELÉ 12V 30-40A CON DIODO



| Sku | Tensione nominale / Rated voltage | Intensità di corrente / Current intensity | Modello / Model | Prodotti compatibili / Compatible products |
|--------------|-----------------------------------|---|------------------------|--|
| 63765 | 12 V | 30/40 A | Con diodo / With diode | 64581 |

RELÈ 20-30A

RELAY 20-30A
RELAIS 20-30A
20-30A RELAIS
RELÉ 20-30A



| Sku | Tensione nominale / Rated voltage | Intensità di corrente / Current intensity | Modello / Model | Prodotti compatibili / Compatible products |
|--------------|-----------------------------------|---|-----------------------------|--|
| 02101 | 12 V | 20/30 A | Senza diodo / Without diode | 12490,64581,69173 |
| 02102 | 24 V | 10/20 A | Senza diodo / Without diode | 12490,64581,69173 |

RELÈ DI POTENZA 12V

POWER RELAY 12V
 RELAIS DE PUISSANCE 12V
 12V LEISTUNGSRELAIS
 RELÉ DE POTENCIA 12V



| Skü | Tensione nominale / Rated voltage | Intensità di corrente / Current intensity | Modello / Model |
|-------|-----------------------------------|---|-----------------------------|
| 64590 | 12 V | 200-500 A | Senza diodo / Without diode |

RELÈ 12V 30A CON FUSIBILE DI PROTEZIONE

RELAY 12V 30A WITH PROTECTION FUSE
 RELAIS 12V 30A AVEC FUSIBLE DE PROTECTION
 RELAIS 12V 30A MIT SCHUTZSICHERUNG
 RELÉ 12V 30A CON FUSIBLE DE PROTECCIÓN



| Skü | Tensione nominale / Rated voltage | Modello / Model |
|-------|-----------------------------------|---|
| 63769 | 12 V | Con fusibile di protezione 30 A, senza diodo / With 30 A protection fuse, without diode |

MICRO RELÈ

MICRO RELAY
 MICRO RELAIS
 MIKRORELAIS
 MICRO RELÉ



| Skü | Tensione nominale / Rated voltage | Intensità di corrente / Current intensity | Modello / Model | Prodotti compatibili / Compatible products |
|-------|-----------------------------------|---|------------------------|--|
| 64584 | 12 V | 10/20 A | Con diodo / With diode | 60063 |
| 64585 | 24 V | 10/20 A | Con diodo / With diode | 60063 |

RELÈ 3 PIN

RELAY 3
 RELAIS 3 BROCHES
 3-POLIGES RELAIS
 RELÉ DE 3 PINES



| Skù | Tensione nominale / Rated voltage | Intensità di corrente / Current intensity | Modello / Model | Temperatura di esercizio / Operating temperature | Prodotti compatibili / Compatible products |
|--------------|-----------------------------------|---|-----------------------------|--|--|
| 57688 | 12 V | 70 A | Senza diodo / Without diode | -40° / +125° C | 57689 |
| 60064 | 24 V | 40 A | Senza diodo / Without diode | -40° / +125° C | 57689 |

MICRO RELÈ

MICRO RELAY
 MICRO RELAIS
 MIKRORELAIS
 MICRO RELÉ

| Skù | Tensione nominale / Rated voltage | Intensità di corrente / Current intensity | Modello / Model | Prodotti compatibili / Compatible products |
|--------------|-----------------------------------|---|-----------------------------|--|
| 60061 | 12 V | 10/20 A | Senza diodo / Without diode | 60063 |
| 60062 | 24 V | 10/20 A | Senza diodo / Without diode | 60063 |

RELÈ SENZA DIODO

RELAY WITHOUT DIODE
 RELAIS SANS DIODE
 RELAIS OHNE DIODE
 RELÉ SIN DIODO



| Skù | Tensione nominale / Rated voltage | Intensità di corrente / Current intensity | Modello / Model | Prodotti compatibili / Compatible products |
|--------------|-----------------------------------|---|-----------------------------|--|
| 63767 | 12 V | 30/40 A | Senza diodo / Without diode | 64581 |
| 63768 | 24 V | 20/10 A | Senza diodo / Without diode | 64581 |

ACCESSORI RELAYS

 RELAY ACCESSORIES
 ACCESSOIRES POUR RELAIS
 RELAIS-ZUBEHÖR
 ACCESORIOS PARA RELÉS

| Skü | Modello / Model | Prodotti compatibili / Compatible products |
|---|---|---|
|  12490 | Base per relè / Relay socket | 00707,02101,02102,57809,63662,63663,63765,63767,63768,118013,118082 |
|  64581 | Base per relè' / Relay socket | 00707,02101,02102,57809,63662,63663,63765,63767,63768,118013,118082 |
|  69173 | Base per relè / Relay socket | 00707,02101,02102,57809,63662,63663,63765,63767,63768,118013,118082 |
|  57689 | Base per relè con staffa / Relay socket with bracket | 09179,57688,60064 |
|  60063 | Base per micro relè / Micro relay socket with bracket | 60061,60062,64584,64585 |



Spie di controllo e strumenti

Control lights and gauges

I prodotti recanti il marchio AMA qui indicati sono realizzati da AMA S.p.A. e destinati a essere utilizzati come ricambi adattabili e non originali. I riferimenti a marchi, codici originali e costruttori di terzi, riportati in corrispondenza degli articoli AMA compatibili, hanno esclusivamente la finalità di identificare il modello, l'applicazione o la destinazione d'uso del prodotto, in conformità a quanto previsto dal Regolamento (CE) n. 1400/2002 e dalla normativa vigente in materia di concorrenza e uso lecito dei marchi di terzi. / The products bearing the AMA brand name listed here are manufactured by AMA S.p.A. and are intended for use as adaptable, non-original spare parts. References to trademarks, original codes and third-party manufacturers, shown alongside compatible AMA items, are intended solely to identify the model, application or intended use of the product, in accordance with Regulation (EC) No. 1400/2002 and current legislation on competition and the lawful use of third-party trademarks.





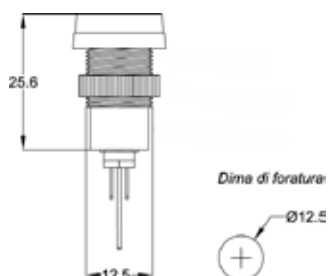







SPIE ROTONDE

ROUND DASHBOARD WARNING LIGHTS
 VOYANTS LUMINEUX RONDS POUR TABLEAU DE BORD
 RUNDE WARNLEUCHTEN FÜR ARMATURENBRETT
 LUCES DE ADVERTENCIA REDONDAS PARA EL TABLERO

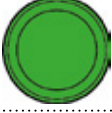

Lampadina non inclusa art. 26049 12V, attacco a faston 6,3x0,8 e art. 26050 24V, attacco a faston 6,3x0,8 / *Bulb not included art. 26049 12V, 6.3x0.8 faston connector and art. 26050 24V, 6.3x0.8 faston connector*

| Skü | Colore / Colour | Funzioni / Functions |
|--------|-----------------|--|
| S14181 | Rosso / Red | Neutra - nessun simbolo / Neutral - no symbol |
| S14151 | Rosso / Red | Generatore / Alternator |
| S14152 | Rosso / Red | Pressione olio / Oil pressure |
| S14153 | Rosso / Red | Temperatura acqua / Water temperature |
| S14155 | Rosso / Red | Filtro aria / Air filter |
| S14156 | Rosso / Red | Luci di parcheggio / Parking lights |
| S14167 | Rosso / Red | Livello olio trasmissione / Transmission oil level |
| S14168 | Rosso / Red | Olio motore / Engine oil |
| S14180 | Rosso / Red | Avaria freni / Brake failure Fallo de frenosDéfaillance des freins |
| S14188 | Rosso / Red | Temperatura olio idraulico / Hydraulic oil temperature |

| Skü | | Colore / Colour | Funzioni / Functions |
|--------|---|--------------------|--|
| S14192 |  | Rosso / Red | Presa di forza (PTO) / Power take-off (PTO) |
| S14175 |  | Arancione / Orange | Neutra - nessun simbolo / Neutral - no symbol |
| S14157 |  | Arancione / Orange | Riserva carburante / Fuel reserve |
| S14158 |  | Arancione / Orange | Candelette / Glow plugs |
| S14159 |  | Arancione / Orange | Marcia lenta / Low speed |
| S14160 |  | Arancione / Orange | Marcia veloce / High speed |
| S14182 |  | Verde / Green | Neutra - nessun simbolo / Neutral - no symbol |
| S14161 |  | Verde / Green | Indicatori di direzione (frece) / Turn indicator |
| S14162 |  | Verde / Green | Luce di posizione / Position light |
| S14163 |  | Verde / Green | Anabbagliante / Low beam lights |
| S14164 |  | Verde / Green | Marcia A-R / Forward / Reverse gear |
| S14165 |  | Blu / Blue | Abbagliante / High beam |

SPIE QUADRATE

SQUARE DASHBOARD WARNING LIGHTS
 VOYANTS LUMINEUX CARRÉS POUR TABLEAU DE BORD
 QUADRATISCHE WARNLEUCHTEN FÜR ARMATURENBRETT
 LUCES DE ADVERTENCIA CUADRADAS PARA EL TABLERO



Lampadina non inclusa art. L26005.O 12V 3W T10 e art. L26016.O 24V 3W T10 / Bulb not included art. L26005.O 12V 3W T10 and art. L26016.O 24V 3W T10

| Skü | Colore / Colour | Funzioni / Functions |
|--------|-----------------|--|
| 02844 | Rosso / Red | Neutra – nessun simbolo / Neutral – no symbol |
| 02854 | Rosso / Red | Batteria scarica / Battery discharged |
| 08060 | Rosso / Red | Freno a mano / Parking brake |
| 08065 | Rosso / Red | Pressione olio / Oil pressure |
| 08066 | Rosso / Red | Temperatura acqua / Water temperature |
| S14002 | Rosso / Red | Temperatura olio idraulico / Hydraulic oil temperature |
| S14004 | Rosso / Red | Filtro aria intasato / Air filter clogged |
| S14019 | Rosso / Red | Temperatura olio meccanico / Engine oil temperature |
| S14024 | Giallo / Yellow | Neutra – nessun simbolo / Neutral – no symbol |
| 08069 | Giallo / Yellow | Riserva carburante / Low fuel |
| 08083 | Giallo / Yellow | Candele/te / Glow plugs |

| Skü | | Colore / Colour | Funzioni / Functions |
|--------|--|-----------------|---|
| S14042 | | Giallo / Yellow | Marcia lenta / Low speed |
| 02843 | | Verde / Green | Neutra - nessun simbolo / Neutral - no symbol |
| 02853 | | Verde / Green | Frecce / Turn indicator |
| 08067 | | Verde / Green | Luce di posizione / Position lights |
| 02855 | | Blu / Blue | Neutra - nessun simbolo / Neutral - no symbol |
| 08068 | | Blu / Blue | Abbagliante / High beam |
| 08084 | | Blu / Blue | Lampada rotante / Rotating beacon |
| S14044 | | Nero / Black | Tappo / Cap |



CONTAORE 12-24V

HOUR METER 12-24V
 COMPTEUR D'HEURES 12-24V
 BETRIEBSSTUNDENZÄHLER 12-24V
 CONTADOR DE HORAS 12-24V

| Skü | | Tensione nominale / Rated voltage | Diametro / Diameter | Specifiche / Specifications | Pinout / Pinout | Temperatura di esercizio / Operating temperature |
|------------|--|--------------------------------------|------------------------|--|---|---|
| 24444 | | 12-24 V | 52 mm | spia lampeggiante di funzionamen- to / Flashing indicator light | Attacco a faston 6,3 mm / 6.3 mm faston connection | -20°C/+80°C |
| IME.107-01 | | 12-24 V | 60 mm | spia lampeggiante di funzionamen- to / Flashing indicator light | Attacco a faston 6,3 mm / 6.3 mm faston connection | -20°C/+80°C |

CONTAORE

HOUR METER
 COMPTEUR D'HEURES
 BETRIEBSSTUNDENZÄHLER
 CONTADOR DE HORAS

| Skü | Tensione nominale / Rated voltage | Tipo visualizzazione / Display type | Grado protezione ip / Degree of protection ip | Temperatura di esercizio / Operating temperature |
|---|-----------------------------------|-------------------------------------|---|--|
| 58595  | 12-80 V | Analogico / Analog | IP66 | -40° / + 85° C |
| 66134  | 10-24 V | Digitale / Digital | IP66 | -20°C/+75°C |
| 68595  | 10-24 V | Analogico / Analog | IP65 | -20°C/+75°C |

CONTAORE ADATTABILE A FIAT 4334916



HOUR METER COMPATIBLE WITH FIAT 4334916
 COMPTEUR D'HEURES COMPATIBLE AVEC FIAT 4334916
 BETRIEBSSTUNDENZÄHLER PASSEND FÜR FIAT 4334916
 CONTADOR DE HORAS COMPATIBLE CON FIAT 4334916



| Skü | Applicazioni | | Rif. Orig. | |
|-------|--------------|---|------------|------------------------------------|
| | Brand | Modello | Brand | Cod. Originale |
| 10676 | FIAT | CINGOLATI SERIE ORO, 450, 480, 500, 540, 550, 600, 640, 850 SUPER | FIAT | 4180290, 4328998, 4334916, 5011839 |

CONTAORE E CONTAGIRI

HOUR METER AND TACHOMETER
 COMPTEUR D'HEURES ET COMPTE-TOURS
 BETRIEBSSTUNDENZÄHLER UND DREHZAHLMESSER
 CONTADOR DE HORAS Y CUENTAVUELTAS

| Skü | Applicazioni | | Rif. Orig. | |
|---|-----------------|------------------------------|-----------------|----------------|
| | Brand | Modello | Brand | Cod. Originale |
| 41917  | MASSEY FERGUSON | FE35 | MASSEY FERGUSON | 1850093M93 |
| 41921  | MASSEY FERGUSON | 35 | MASSEY FERGUSON | 894428M91 |
| 41934  | MASSEY FERGUSON | 165, 168, 175, 178, 185, 188 | MASSEY FERGUSON | 898489M91 |

STRUMENTO ANALOGICO E DIGITALE CON 12 SPIE A LED , STRUMENTO LIVELLO CARBURANTE E CONTAORE 9-30V

ANALOG AND DIGITAL INSTRUMENT WITH 12 LED INDICATORS, FUEL LEVEL GAUGE AND HOUR METER 9-30V
 INSTRUMENT ANALOGIQUE ET NUMÉRIQUE AV. 12 VOYANTS LED, JAUGE DE NIVEAU DE CARBURANT ET COMPTEUR D'HE
 ANALOGES UND DIGITALE INSTRUMENT MIT 12 LED-KONTROLLEUCHTEN, KRAFTSTOFFSTANDANZEIGE UND BETRIEBSST
 INSTRUMENTO ANALÓGICO Y DIGITAL CON 12 TESTIGOS LED, MEDIDOR DE NIVEL DE COMBUSTIBLE Y CONTADOR DE H



| Skü | Tensione nominale / Rated voltage | Tipo visualizza- zione / Display type | Funzioni / Functions | Diametro di foratura / Drilling diameter | Illuminazio- ne / Lighting | Pinout / Pinout | Grado protezione ip / Degree of protection ip | Temperatura di esercizio / Opera- ting temperature |
|-------|--------------------------------------|---|---|--|-------------------------------|---|---|--|
| 63908 | 12-24 V | Analogico - di- gitale / Analog - Digital | Livello carburante, contaore, 12 spie: batteria, pressone olio, temperatura acqua, filtro aria, riserva carburante, preriscaldamento candele, abbaglianti, indicatori di direzione, anabbaglianti, freno di stazionamento, marcia avanti, retromarcia / Fuel level, hour meter, 12 indicators: battery, oil pressure, water temperature, air filter, fuel reserve, glow plug preheating, high beam, direction indicators, low beam, parking brake, forward gear, reverse gear | 100 mm | Presente/ Available | Connettore ITT 24 poli / 24-pin ITT connector | IP65 front protection | -25° / +85° C |

CONTAGIRI CON CONTAORE 12-24V CON TECNOLOGIA STEPPER MOTOR 4000 RPM

TACHOMETER WITH HOUR METER 12-24V WITH STEPPER MOTOR TECHNOLOGY 4000 RPM
 TACHYMÈTRE AVEC COMPTEUR D'HEURES 12-24V AVEC TECHNOLOGIE MOTEUR PAS À PAS 4000 TR/MIN
 DREHZAHLMESSER MIT BETRIEBSSTUNDENZÄHLER 12-24V MIT SCHRITTMOTOR-TECHNOLOGIE 4000 U/MIN
 TACÓMETRO CON CONTADOR DE HORAS 12-24V CON TECNOLOGÍA DE MOTOR PASO A PASO 4000 RPM



Art. ricambio IME.125 connettore / Spare part IME.125 connector

| Skü | Tensione nominale / Rated voltage | Tipo visualizzazione / Display type | Diametro di foratura / Drilling diameter | Illuminazione / Lighting | Pinout / Pinout | Grado protezione ip / Degree of protection ip | Temperatura di esercizio / Operating temperature |
|-------|--------------------------------------|--|---|-----------------------------|--------------------------------|--|---|
| 09174 | 10-32 V | analogico - digitale | 100 mm | Presente / Available | Connettore Minifit Jr a 4 poli | IP65 frontale , retro IP30 | -20° / + 85° C |
| 58597 | 10-32 V | analogico - digitale | 80 mm | Presente / Available | Connettore Minifit Jr a 4 poli | IP65 frontale , retro IP30 | -20° / + 85° C |

INDICATORI TEMPERATURA ACQUA

WATER TEMPERATURE GAUGES
 INDICATEURS DE TEMPÉRATURE DE L'EAU
 WASSERTHERMOMETER
 INDICADORES DE TEMPERATURA DEL AGUA

Art. ricambio IME.122 connettore / Spare part IME.122 connector

| Skü | Tensione nominale / Rated voltage | Tipo visualizzazione / Display type | Scala / Scale | Ohm / Ohm | Illuminazione / Lighting | Diametro di foratura / Drilling diameter | Pinout / Pinout | Grado protezione ip / Degree of protection ip | Temperatura di esercizio / Opera- ting temperature |
|-------|--------------------------------------|--|------------------|--------------|-----------------------------|--|--|---|--|
| 09194 | 12 V | Analogico / Analog | 40°-120° C | 1220 - 88 | Presente / Available | 52,5 mm | Connettore Minifit Jr a 4 poli / 4-pin Mini-Fit Jr connector | IP65 frontale, IP30 retro | -25° / +85° C |
| 09176 | 24 V | Analogico / Analog | 40°-120° C | 1220 88 | Presente / Available | 52,5 mm | Connettore Minifit Jr a 4 poli / 4-pin Mini-Fit Jr connector | IP65 frontale, IP30 retro | -25° / +85° C |

INDICATORI TEMPERATURA ACQUA 12V

WATER TEMPERATURE GAUGE 12V
 INDICATEUR DE TEMPÉRATURE DE L'EAU 12V
 12V WASSERTHERMOMETER
 INDICADOR DE TEMPERATURA DEL AGUA 12V







Art. ricambio IME.122 connettore / Spare part IME.122 connector

| Skü | Tensione nominale / Rated voltage | Tipo visualizzazione / Display type | Scala / Scale | Ohm / Ohm | Illuminazione / Lighting | Diametro di foratura / Drilling diameter | Pinout / Pinout | Grado protezione ip / Degree of protection ip | Temperatura di esercizio / Operating temperature |
|--------------|-----------------------------------|-------------------------------------|---------------|-----------|--------------------------|--|--|---|--|
| 63906 | 12 V | Analogico / Analog | Grafica | 203 - 18 | Presente / Available | 52,5 mm | Connettore Minifit Jr a 4 poli / 4-pin Mini-Fit Jr connector | IP65 frontale, IP30 retro | -25° / +85° C |

INDICATORI TEMPERATURA ACQUA CAPILLARE

CAPILLARY WATER TEMPERATURE GAUGE
 JAUGE DE TEMPÉRATURE DE L'EAU À CAPILLAIRE
 KAPILLAR-TEMPERATURANZEIGE FÜR WASSER
 INDICADOR DE TEMPERATURA DEL AGUA CAPILAR

| Skü | Tipo visualizzazione / Display type | Scala / Scale | Tipo alimentazione / Power type | Filettatura femmina / Female threading | Filettatura maschio / Male threading | Lunghezza / Length | Diametro di foratura / Drilling diameter | Illuminazione / Lighting |
|--------------|--|---------------|---------------------------------|--|--------------------------------------|--------------------|--|--------------------------|
| 01909 |  analogico / analog | grafica | Meccanico / Mechanical | 5/8"x18 | 1/2" | 80 cm | 52,5 mm | presente / available |
| 01940 |  analogico / analog | grafica | Meccanico / Mechanical | 5/8"x18 | 1/2" | 1,32 m | 52,5 mm | presente / available |
| 01941 |  analogico / analog | grafica | Meccanico / Mechanical | 5/8"x18 | 1/2" | 1,67 m | 52,5 mm | presente / available |
| 01942 |  analogico / analog | grafica | Meccanico / Mechanical | 5/8"x18 | 1/2" | 2,07 m | 52,5 mm | presente / available |
| 02000 |  analogico / analog | grafica | Meccanico / Mechanical | 5/8"x18 | 1/2" | 1,78 m | 52,5 mm | presente / available |

INDICATORE TEMPERATURA ACQUA E LIVELLO CARBURANTE

WATER TEMPERATURE AND FUEL LEVEL GAUGE
 JAUGE TEMPÉRATURE EAU ET NIVEAU CARBURANT
 ANZEIGE WASSERTEMPERATUR UND KRAFTSTOFFSTAND
 INDICADOR TEMPERATURA AGUA Y NIVEL COMBUSTIBLE



| Sku | Brand / Brand | Modello / Model | MPN / MPN |
|-------|---------------|---|-----------|
| 41964 | CNH | Serie Oro: 450, 480, 500, 550, 600, 640 | 4334917 |

INDICATORE LIVELLO CARBURANTE

FUEL LEVEL INDICATOR
 INDICATEUR DE NIVEAU DE CARBURANT
 KRAFTSTOFFSTAND-ANZEIGER
 INDICADOR DE NIVEL DE CARBURANTE



Art. ricambio IME.122 connettore / Spare part IME.122 connector

| Sku | Tensione nominale / Rated voltage | Tipo visualizzazione / Display type | Scala / Scale | Ohm / Ohm | Diametro di foratura / Drilling diameter | Pinout / Pinout | Illuminazione / Lighting | Grado protezione ip / Degree of protection ip | Temperatura di esercizio / Operating temperature |
|-------|-----------------------------------|-------------------------------------|---------------|-----------|--|--|--------------------------|---|--|
| 09172 | 12 V | analogico / analog | 0-4/4 | 5-332 | 52,5 mm | connettore Minifit Jr 4 poli / 4-pin Mini-Fit Jr connector | presente / available | IP65 frontale, IP30 retro | -25° / +85° C |
| 09173 | 24 V | analogico / analog | 0-4/4 | 5-332 | 52,5 mm | connettore Minifit Jr 4 poli / 4-pin Mini-Fit Jr connector | presente / available | IP65 frontale, IP30 retro | -25° / +85° C |

INDICATORE PRESSIONE OLIO

OIL PRESSURE GAUGE
 MANOMETRE DE PRESSION D'HUILE
 ÖLDRUCKMANOMETER
 INDICADOR PRESIÓN ACEITE

| Sku | Tensione nominale / Rated voltage | Tipo alimentazione / Power type | Scala / Scale | Filettatura maschio / Male threading | Filettatura femmina / Female threading | Diametro di foratura / Drilling diameter | Grado protezione ip / Degree of protection ip |
|-------|-----------------------------------|---------------------------------|---------------|--------------------------------------|--|--|---|
| 00676 | 12 V | Meccanico / Mechanical | 0-7 bar | 10x1 | | 52,5 mm | IP65 frontale |
| 00660 | 12 V | Meccanico / Mechanical | 0-7 bar | | 3/8" -24UNF | 52,5 mm | IP65 frontale |
| 00621 | 12 V | Meccanico / Mechanical | 0-8 bar | 1/8" - 27NPT | | 52,5 mm | IP65 frontale |

PRESSOSTATO OLIO MOTORE 12V 1/8 27 NPTF

ENGINE OIL PRESSURE SWITCH 12V 1/8-27 NPTF
 PRESSOSTAT D'HUILE MOTEUR 12V 1/8-27 NPTF
 ÖLDRUCKSCHALTER FÜR MOTOR 12V 1/8-27 NPTF
 PRESOSTATO DE ACEITE DE MOTOR 12V 1/8-27 NPTF

Articoli a ricambio

55572 Kit porta femmina 2 vie SuperSeal

| Sku | Tensione nominale / Rated voltage | Filettatura femmina / Female threading | Chiave / Spanner | Numero vie / Number of ways | Grado protezione ip / Degree of protection ip |
|-------|-----------------------------------|--|------------------|-----------------------------|---|
| 55902 | 12 V | 1/8 27 NPTF | 22 | 2 | IP67 |

PRESSOSTATO PER STRUMENTO PRESSIONE OLIO

OIL PRESSURE SWITCH
 INTERRUPTEUR PRESSION D'HUILE
 ÖLDRUCKSCHALTER
 INTERRUPTOR DE PRESIÓN DE ACEITE



| Sku | Filettatura maschio / Male threading | Passo / Pitch | Chiave / Spanner | Scala / Scale | Taratura / Calibration | Modello / Model |
|-------|--------------------------------------|---------------|------------------|---------------|------------------------|-----------------|
| 03745 | M14 | 1,5 | 19 | 0-8 bar | Veglia | 1 polo |

INDICATORE PRESSIONE OLIO

OIL PRESSURE GAUGE
 MANOMETRE DE PRESSION D'HUILE
 ÖLDRUCKMANOMETER
 INDICADOR PRESIÓN ACEITE



| Sku | Tensione nominale / Rated voltage | Tipo alimentazione / Power type | Scala / Scale | Diametro di foratura / Drilling diameter | Grado protezione ip / Degree of protection ip | Pinout / Pinout | Ohm / Ohm | Illuminazione / Lighting |
|-------|-----------------------------------|---------------------------------|---------------|--|---|---|-----------|--------------------------|
| 01915 | 12 V | Elettrico / Electric | 0-8 bar | 52,5 mm | IP65 frontale, IP30 posteriore | Connettore Minifit Jr a 4 poli / 4-pin Minifit Jr connector | 245-20 | presente / available |

VOLTMETRO

VOLTMETER
INDICATEUR VOLTMÈTRE
ÖLDRUCKMANOMETER
VOLTÍMETRO



| Skü | Tensione nominale / Rated voltage | Tipo visualizzazione / Display type | Escursione / Excursion | Pinout / Pinout | Illuminazione / Lighting | Diametro di foratura / Drilling diameter | Grado protezione ip / Degree of protection ip | Temperatura di esercizio / Operating temperature |
|--------------|-----------------------------------|-------------------------------------|------------------------|--|--------------------------|--|---|--|
| 09170 | 12 V | analogico / analog | 8 -16 V | Connettore Minifit Jr a 4 poli / 4-pin Mini-Fit Jr connector | presente / available | 52,5 mm | IP65 frontale | -25° / +85° C |

CRUSCOTTO PER MOTOAGRICOLE

DASHBOARD FOR AGRICULTURAL VEHICLES
TABLEAU DE BORD POUR VÉHICULES AGRICOLES
ARMATURENBRETT FÜR LANDWIRTSCHAFTSAHRZEUGE
TABLERO PARA VEHÍCULOS AGRÍCOLAS

| Skü | Descrizione / Description | Dimensioni / Dimensions |
|--------------|--|-------------------------|
| 02821 | Corpo cruscotto con fori per l'allestimento personalizzato dell'impianto luci / Dashboard body with holes for customized lighting system setup | 140,6x124,5x85,5mm |
| 02840 | Cruscotto non cablato per motoagricole provviste di batteria. Comprende quadro avviamento 0-1-2, quadro luce 4 posizioni con clacson, deviatore per frecce, spia verde, spia rossa, spia con vetro nero per poter inserire una ulteriore funzione. / Unwired dashboard for agricultural machines with battery. Includes: ignition switch 0-1-2, 4-position light switch with horn, turn signal switch, green indicator light, red indicator light, and black-lens indicator light for an additional function | 140,6x124,5x85,5mm |

PANNELLO STRUMENTI

INSTRUMENT PANEL
TABLEAU DE BORD
INSTRUMENTENTAFEL
PANEL DE INSTRUMENTOS



| Skü | Descrizione / Description |
|--------------|---|
| 10619 | Quadro strumenti completo adattabile al rif. Fiat 4334915. / Complete instrument panel adaptable to Fiat ref. 4334915 |

PANNELLO STRUMENTI

INSTRUMENT PANEL
TABLEAU DE BORD
INSTRUMENTENTAFEL
PANEL DE INSTRUMENTOS



| Skü | Descrizione / Description |
|--------------|---|
| 10620 | Quadro strumenti completo adattabile al rif. Fiat 5133783. / Complete instrument panel adaptable to Fiat ref. 5133783 |

TERMISTORI

THERMISTANCE
THERMISTANCE
THERMISTOR
TERMISTOR TEMPERATURA



| Skü | Tensione nominale / Rated voltage | Filettatura maschio / Male threading | Ohm / Ohm | Passo / Pitch | Chiave / Spanner | Temperatura di esercizio / Operating temperature |
|--------------|-----------------------------------|--------------------------------------|-------------|---------------|------------------|--|
| 03741 | 12/24 V | M22x1,5 | 1350 - 40,5 | 1,5 | 27 | 40° / 150° C |
| 03742 | 12/24 V | M16x1,5 | 1350 - 40,5 | 1,5 | 21 | 40° / 150° C |
| 03743 | 12/24 V | M14x1,5 | 1350 - 40,5 | 1,5 | 21 | 40° / 150° C |





PRESSOSTATI PER SPIA OLIO MOTORE

OIL PRESSURE SWITCHES FOR ENGINE OIL WARNING LIGHT
PRESSOSTAT D'HUILE
ÖLDRUCKSCHALTER
CONMUTADOR DE PRESIÓN ACEITE

| Skü | Filettatura maschio / Male threading | Passo / Pitch | Contatti elettrici / Electrical contacts | Pressione massima / Maximum pressure | Chiave / Spanner | Pinout / Pinout | Materiali / Material |
|--------------|--------------------------------------|---------------|--|--------------------------------------|------------------|-----------------|----------------------|
| 03695 | M12 | 1.5 | NC | 0,50 Bar | 22 | 6,3 mm | Acciaio / Steel |
| 03697 | 1/8" | 27 NPTF | NC | 0,60 Bar | 22 | 6,3 mm | Acciaio / Steel |
| 03698 | M12 | 1,75 | NC | 1,70 Bar | 22 | 6,3 mm | Acciaio / Steel |
| 03740 | M12 | 1.5 | NC | 0,60 Bar | 22 | 6,3 mm | Acciaio / Steel |

SENSORE DI LIVELLO CARBURANTE AD ASTA

FUEL SENDER
 FLOTTEURS DE RÉSERVOIR
 TANK FLOATERS
 AFORADOR DE COMBUSTIBLE

| Skü | Brand / Brand | Tensione nominale / Rated voltage | Scala / Scale | Taratura / Calibration | Note / Notes | Pinout / Pinout | Materiali / Material |
|--|---------------|-----------------------------------|---------------|--|---|--|----------------------|
|  01193 | Cobo | 12-24 V | 313 | Livello carburante: E: 313 mm; 1/4: 264 mm; 2/4: 169 mm; 4/4: 31,5 mm / Fuel level: E: 313 mm; 1/4: 264 mm; 2/4: 169 mm; 4/4: 31.5 mm | 2 tubi, senza filtro di aspirazione / 2 tubes, without suction filter | Cavo 150 mm con connettore AMP / 150 mm cable with AMP connector | plastica / plastic |
|  01194 | Cobo | 12-24 V | 389 | Livello carburante E: 389 mm; R: 368 mm; 1/4: 338 mm; 2/4: 225 mm; 4/4: 41 mm; / Fuel level: E: 389 mm; R: 368 mm; 1/4: 338 mm; 2/4: 225 mm; 4/4: 41 mm; | 2 tubi, senza filtro di aspirazione / 2 tubes, without suction filter | Cavo 800 mm con connettore AMP / 800 mm cable with AMP connector | plastica / plastic |
|  56862 | Ama | 12-24 V | 313 | Livello carburante E: 313 mm; 1/4: 264 mm; 2/4: 169 mm; 4/4: 31,5 mm / Fuel level: E: 313 mm; 1/4: 264 mm; 2/4: 169 mm; 4/4: 31.5 mm | 2 tubi, senza filtro di aspirazione / 2 tubes, without suction filter | Cavo 150 mm con connettore AMP / 150 mm cable with AMP connector | metallo / metal |
|  56875 | Ama | 12-24 V | 389 | Livello carburante E: 389 mm; R: 368 mm; 1/4: 338 mm; 2/4: 225 mm; (4/4): 41 mm / Fuel level: E: 389 mm; R: 368 mm; 1/4: 338 mm; 2/4: 225 mm; (4/4): 41 mm | 2 tubi, senza filtro di aspirazione / 2 tubes, without suction filter | Cavo 500 mm con connettore AMP / 500 mm cable with AMP connector | metallo / metal |

SENSORI DI LIVELLO CARBURANTE AD ASTA

FUEL SENDER
 FLOTTEURS DE RÉSERVOIR
 TANK FLOATERS
 AFORADOR DE COMBUSTIBLE



| Skü | Brand / Brand | Tensione nominale / Rated voltage | Lunghezza / Length | Taratura / Calibration | Materiali / Material | Note / Notes | Fissaggio / Fastening | Diametro / Diameter | Pinout / Pinout |
|-------|---------------|-----------------------------------|--------------------|---|----------------------|--|--|---------------------|---|
| 27248 | Cobo | 12-24 V | 89,40 cm | Livello carburante: E: 224 ÷ 877 mm; R: 206 ÷ 791,5 mm; 1/4: 197 ÷ 747,5 mm; 2/4: 134,5 ÷ 438 mm; 4/4: 30,5 ÷ 103,5 mm / Fuel level empty: 224 ÷ 877 mm; Fuel level reserve: 206 ÷ 791.5 mm; Fuel level 1/4: 197 ÷ 747.5 mm; Fuel level 2/4: 134.5 ÷ 438 mm; Fuel level full (4/4): 30.5 ÷ 103.5 mm | metallo / metal | Senza filtro di aspirazione / Without suction filter | Con viti 6 fori Ø 4,5 mm, Foratura Ø 60,3 mm / With 6 screws, 6 holes Ø 4.5 mm, drilling Ø 60.3 mm | 60,3 mm | diretto al dispositivo / Device-direct connection |

SENSORI DI LIVELLO CARBURANTE A TUBO

FUEL SENDER
 FLOTTEURS DE RÉSERVOIR
 TANK FLOATERS
 AFORADOR DE COMBUSTIBLE

Articoli a ricambio

55573 Kit porta femmina 3 vie SuperSeal

| Skù | Tensione nominale / Rated voltage | Lunghezza / Length | Ohm / Ohm | Taratura / Calibration | Note / Notes | Materiali / Material | Fissaggio / Fastening | Diametro / Diameter | Pinout / Pinout |
|---------------|-----------------------------------|--------------------|-----------|---|--|-----------------------|---|---------------------|--|
| 58587 | 12-24 V | 37,40 cm | 5-330 | Livello carburante: E: 374 mm; R: 315 mm; 1/4: 284 mm; 2/4: 220 mm; 4/4: 64 mm; / Fuel level: E: 374 mm; R: 315 mm; 1/4: 284 mm; 2/4: 220 mm; 4/4: 64 mm; | 2 tubi, con filtro di aspirazione e scarico/ 2 tubes, without suction filter | alluminio / aluminium | Con viti 6 fori Ø 5,3 mm, Foratura Ø 60,3 mm / 6 holes Ø 5.3 mm, drilling Ø 60.3 mm | 60,3 mm | Cavo 200 mm con connettore AMP 3 vie / 200 mm cable, AMP 3-way connector |
| 58589 | 12-24 V | 42 cm | 5-330 | Livello carburante: E: 420 mm; R: 362 mm; 1/4: 311 mm; 2/4: 260 mm; 4/4: 65 mm; / Fuel level: E: 420 mm; R: 362 mm; 1/4: 311 mm; 2/4: 260 mm; 4/4: 65 mm; | 2 tubi, con filtro di aspirazione e scarico/ 2 tubes, without suction filter | alluminio / aluminium | Con viti 6 fori Ø 5,3 mm, Foratura Ø 60,3 mm / 6 holes Ø 5.3 mm, drilling Ø 60.3 mm | 60,3 mm | Cavo 200 mm con connettore AMP 3 vie / 201 mm cable, AMP 3-way connector |
| G31137 | 12-24 V | 29 cm | 5-330 | Livello carburante: E: 290 mm; R: 262 mm; 1/4: 198 mm; 2/4: 130 mm; 4/4: 41,2 mm; / Fuel level: E: 290 mm; R: 262 mm; 1/4: 198 mm; 2/4: 130 mm; 4/4: 41,2 mm; | 2 tubi, con filtro di aspirazione e scarico/ 2 tubes, without suction filter | alluminio / aluminium | Con viti 6 fori Ø 5,3 mm, Foratura Ø 60,3 mm / 6 holes Ø 5.3 mm, drilling Ø 60.3 mm | 60,3 mm | Cavo 200 mm con connettore AMP 3 vie / 202 mm cable, AMP 3-way connector |

SENSORE DI LIVELLO CARBURANTE 12-24V AD ASTA, PROFONDITÀ DI INSTALLAZIONE 489,5 MM

ROD-TYPE FUEL LEVEL SENSOR 12-24V, INSTALLATION DEPTH 489.5 MM
 CAPTEUR DE NIVEAU DE CARBURANT À TIGE 12-24V, PROFONDEUR D'INSTALLATION 489,5 MM
 KRAFTSTOFF-FÜLLSTANDSSENSOR MIT STAB 12-24V, EINBAUTIEFE 489,5 MM
 SENSOR DE NIVEL DE COMBUSTIBLE TIPO VARILLA 12-24V, PROFUNDIDAD DE INSTALACIÓN 489,5 MM



| Skù | Brand / Brand | Tensione nominale / Rated voltage | Lunghezza / Length | Taratura / Calibration | Materiali / Material | Note / Notes | Fissaggio / Fastening | Pinout / Pinout |
|------------------|---------------|-----------------------------------|--------------------|---|----------------------|--|---|--|
| NH5150091 | Cobo | 12-24 V | 48,95 cm | Livello carburante: E: 472 mm; 1/4: 430 mm; 2/4: 304 mm; 4/4: 37 mm | plastica / plastic | Senza filtro di aspirazione / Without suction filter | Con viti 6 fori Ø 4,2 mm, Foratura Ø 60,3 mm / 6-hole Ø 4.2 mm, drilling Ø 60.3 mm, with screws | Cavo 200 mm con connettore AMP 2 vie / 200 mm cable, AMP 2-way connector |

SENSORE DI LIVELLO CARBURANTE AD ASTA

FUEL SENDER
 FLOTTEURS DE RÉSERVOIR
 TANK FLOATERS
 AFORADOR DE COMBUSTIBLE



| Sku | Brand / Brand | Tensione nominale / Rated voltage | Lunghezza / Length | Taratura / Calibration | Materiali / Material | Note / Notes | Fissaggio / Fastening | Pinout / Pinout |
|-------|---------------|-----------------------------------|--------------------|---|----------------------|--|---|-------------------------------|
| 10624 | Ama | 12-24 V | 35 cm | Livello carburante: E: 333 mm; R: 300 mm; 2/4: 186 mm ; 4/4: 40 mm; | metallo/ metal | Senza filtro di aspirazione / Without suction filter | Con viti 6 fori Ø 4,5 mm, Foratura Ø 60,3 mm / 6-hole Ø 4.2 mm, drilling Ø 60.3 mm, with screws | faston 6,3 mm / 6,3 mm faston |

INTERRUTTORI A LEVETTA

TOGGLE SWITCHES
 INTERRUPTEURS À BASCULE
 KIPPSCHALTER
 INTERRUPTORES DE PALANCA



Articoli a ricambio



64529 Cappuccio di protezione completo con dado

| Sku | Tensione nominale / Rated voltage | Intensità di corrente / Current intensity | Funzioni / Functions | Contatti elettrici / Electrical contacts | Temperatura di esercizio / Operating temperature |
|-------|-----------------------------------|---|----------------------|--|--|
| 64416 | 250-400 V | 15-10 A | MOM-OFF-MOM | 6,3 in lega argento/nichel / 6,3 silver/nickel alloy | -20° / +50° C |
| 64423 | 250-400 V | 15-10 A | ON-OFF | 6,3 in lega argento/nichel / 6,3 silver/nickel alloy | -20° / +50° C |
| 64526 | 250-400 V | 15-10 A | ON-ON | 6,3 in lega argento/nichel / 6,3 silver/nickel alloy | -20° / +50° C |
| 64527 | 250-400 V | 15-10 A | ON-OFF-MOM | 6,3 in lega argento/nichel / 6,3 silver/nickel alloy | -20° / +50° C |
| 64528 | 250-400 V | 15-10 A | ON-OFF-ON | 6,3 in lega argento/nichel / 6,3 silver/nickel alloy | -20° / +50° C |

INTERRUTTORIE A LEVETTA ON-OFF



TOGGLE SWITCHES ON-OFF
 INTERRUPTEURS À BASCULE ON-OFF
 KIPPSCHALTER ON-OFF
 INTERRUPTORES DE PALANCA ON-OFF



| Sku | Funzioni / Functions | Materiali / Material | Note / Notes |
|-------|----------------------|----------------------|---|
| 00786 | ON-OFF | plastica / plastic | attacco a faston 6,3 mm / 6,3 mm faston terminals |

INTERRUTTORI A TIRETTO



PULL SWITCHES
 INTERRUPTEURS À TIRETTE
 ZUGSCHALTER
 INTERRUPTORES DE TIRO

| Skü | img. | Tensione nominale / Rated voltage | Intensità di corrente / Current intensity | Ø di foratura / Drilling ø |
|-------|---|-----------------------------------|---|----------------------------|
| 44621 |  | 12 V | 10 A | Ø 14,2 mm |
| 44622 |  | 12 V | 10 A | Ø 14,2 mm |

INTERRUTTORI LUCI DI ARRESTO A SCATTO RAPIDO

QUICK-ACTION BRAKE LIGHT SWITCHES
 INTERRUPTEURS DE FEU DE FREIN À DÉCLENCHEMENT RAPIDE
 SCHNELLAUSLÖSENDE BREMSLICHTSCHALTER
 INTERRUPTORES DE LUZ DE FRENO DE ACCIÓN RÁPIDA

Articoli a ricambio

| | | |
|---|---------------|--|
|  | 01121D | Cappuccio di protezione per deviatore art. 01121 |
|  | 09864 | Cappuccio di protezione per deviatore art. 09863 |

| Skü | Tensione nominale / Rated voltage | Brand / Brand | Modello / Model | Contatti elettrici / Electrical contacts | Connettore / Connector | Grado protezione ip / Degree of protection ip | Temperatura di esercizio / Operating temperature |
|-------|-----------------------------------|---------------|-----------------------------|--|---|---|--|
| 01121 | 12-24 V | Cobo | Scatto rapido / Snap-action | 3 | faston 6,3 mm / 6,3 mm faston | IP65 | -20° / + 85° C |
| 09863 | 12-24 V | Cobo | Scatto rapido / Snap-action | 4 | connettore non incluso Art. I05010.2 / Connector not included Art. I05010.2 | IP67 | -20° / + 85° C |
| 55687 | 12-24 V | Ama | Scatto rapido / Snap-action | 4 | Art. 55574 non incluso / Pn 55574 not included | IP67 | -40°C; +85°C |
| 55688 | 12-24 V | Cobo | Scatto rapido / Snap-action | 4 | | IP66 | -40°C; +85°C |
| 55689 | 12-24 V | Cobo | Scatto rapido / Snap-action | 3 | Art. 55573 non incluso / Pn 55573 not included | IP67 | -20°C a +85°C |

INTERRUTTORI LUCI FRENO MECCANICO

BRAKE LIGHT SWITCH
CONTACTEUR DE FEU STOP
BREMSLICHTSCHALTER
INTERRUPTOR LUZ FRENO



| Sku | Modello / Model | Filettatura maschio / Male threading | Passo / Pitch | Chiave / Spanner | Altezza / Height |
|-------|------------------------|--------------------------------------|---------------|------------------|------------------|
| 05523 | Meccanico / Mechanical | M12 | 1,5 | 19 | 54,50 mm |
| 05590 | Meccanico / Mechanical | M12 | 1,5 | 19 | 70 mm |

INTERRUTTORI LUCI FRENO A MOLLA

BRAKE LIGHT SWITCH WITH SPRING
CONTACTEUR DE FEU STOP À RESSORT
BREMSLICHTSCHALTER MIT FEDER
INTERRUPTOR DE LUZ DE FRENO CON RESORTE



| Sku | Tensione nominale / Rated voltage | Modello / Model | Funzioni / Functions | Carico max 12V / Max. load 12V | Carico max 24V / Max. load 24V | Contatti elettrici / Electrical contacts |
|-------|-----------------------------------|-------------------------|--|--------------------------------|--------------------------------|--|
| 03956 | 12-24 V | a molla / spring-loaded | Posizione a riposo disinserito (NA) / Reset position disconnected (NA) | 5A | 2,5A/ | Viti M3 / M3 screws |
| 03957 | 12-24 V | a molla / spring-loaded | Posizione a riposo inserito (NC) / Reset position connected (NC) | 5A | 2,5A/ | Viti M3 / M3 screws |

INTERRUTTORE LUCI FRENO IDRAULICO

BRAKE LIGHT HYDRAULIC SWITCH
INTERRUPTEUR HYDRAULIQUE DE FEU STOP
HYDRAULISCHER SCHALTER DES STOP-LICHTS
INTERRUPTOR HIDRÁULICO DE LA LUZ DE FRENO



| Sku | Modello / Model | Filettatura maschio / Male threading | Passo / Pitch | Chiave / Spanner | Grado protezione ip / Degree of protection ip | Temperatura di esercizio / Operating temperature |
|-------|-----------------------|--------------------------------------|---------------|------------------|---|--|
| 09180 | idraulico / hydraulic | M10 | 1 | 22 | IP54 | -15° / +100° C |

INTERRUTTORE LUCI DI ARRESTO MECCANICO M12X1,25

MECHANICAL BRAKE LIGHT SWITCH M12X1.25
 INTERRUPTEUR MÉCANIQUE DE FEU DE FREIN M12X1,25
 MECHANISCHER BREMSLICHTSCHALTER M12X1,25
 INTERRUPTOR MECÁNICO DE LUZ DE FRENO M12X1,25



| Skü | Funzioni / Functions | Modello / Model | Tensione nominale / Rated voltage | Carico max 12V / Max. load 12V | Filettatura maschio / Male threading | Passo / Pitch | Chiave / Spanner | Contatti elettrici / Electrical contacts |
|-------|--------------------------------------|---------------------------|--------------------------------------|-----------------------------------|---|---------------|---------------------|---|
| 02429 | luci arresto / break light switch | Meccanico / Mechanical | 12 V | 6A | M12 | 1,25 | 19 | 2 |

INTERRUTTORE LUCI FRENO





BRAKE LIGHT SWITCH
 INTERRUPTEUR DE FEU STOP
 BREMSLICHTSCHALTER
 INTERRUPTOR LUZ FRENO



| Skü | Brand / Brand | Modello / Model | Chiave / Spanner | Filettatura maschio / Male threading |
|-------|---------------|-----------------------|------------------|--------------------------------------|
| 15528 | Ama | idraulico / hydraulic | 22 | 1/8x27 NPTF |





INTERRUTTORI DI FINECORSA

LIMIT SWITCH
 INTERRUPTEURS DE FIN DE COURSE
 ENDSCHALTER
 INTERRUPTORES DE FIN DE CARRERA

| Skü | Modello / Model | Funzioni / Functions | Pinout / Pinout | Grado protezione ip / Degree of protection ip | Temperatura di esercizio / / Operating temperature | Prodotti compatibili / Compatible products |
|--------|--|-------------------------------------|---|--|---|---|
| 55712 |  a pistoncino / with plunger | 1NO+1NC | con connettore Deutsch integrato / Integrated Deutsch connector | IP67 | -25° / +70° C | 57623,57683 |
| 55713 |  con comando a rotella / with roller | 1NO+1NC | con connettore Deutsch integrato / Integrated Deutsch connector | IP67 | -25° / +70° C | 57623,57683 |
| 55714 |  ad asta a molla / with spring rod | 1NO+1NC | con connettore Deutsch integrato / Integrated Deutsch connector | IP67 | -25° / +70° C | 57623,57683 |
| 115070 |  ad asta a molla / with spring rod | 1NO+1NC | foro per PG 13,5 presscavo / Hole for PG 13.5 cable gland | IP67 | -25° / +80° C | 57623,57683 |
| 115121 |  con comando a rotel- la / with spring rod | 1NO+1NC / 1NO+1NC fast action | foro per PG 13,5 presscavo / Hole for PG 13.5 cable gland | IP67 | -25° / +80° C | 57623,57683 |





INTERRUTTORE A PULSANTE PNEUTRON SIMBOLO FRECCIA

PNEUTRON PUSH BUTTON SWITCH
 INTERRUPTEUR À BOUTON PNEUTRON
 PNEUTRON DRUCKTASTER
 INTERRUPTOR DE BOTÓN PNEUTRON

| Skü | Brand / Brand | Tensione nominale / Rated voltage | Illuminazione / Lighting | Funzioni / Functions | Grado protezione ip / Degree of protection ip | Intensità di corrente / Current intensity | Temperatura di esercizio / Operating temperature | Descrizione / Description | Prodotti compatibili / Compatible products |
|--|---------------|-----------------------------------|--------------------------|---|---|---|--|--|--|
|  55621 | Pneutron | 48 V | no | Sollevamento/abbassamento / Raise/Lower | IP67 attacco - IP64 parte superiore | 0,3 | -25°C a 100°C | SAME DEUTZ FAHR / SAME 2.7659.182.0, DEUTZ FAHR 2.7659.182.0 | 55573 |
|  55622 | Pneutron | 48 V | no | Sollevamento/abbassamento / Raise/Lower | IP67 attacco - IP64 parte superiore | 0,3 | -25°C a 100°C | SAME DEUTZ FAHR / SAME 0441 2688, DEUTZ FAHR 0441 2688 | 55573 |
|  55623 | Pneutron | 48 V | no | Sollevamento/abbassamento / Raise/Lower | IP67 attacco - IP64 parte superiore | 0,3 | -25°C a 100°C | SAME DEUTZ FAHR / SAME 2.7659.141.0, DEUTZ FAHR 2.7659.141.2 | 55573 |
|  55624 | Pneutron | 48 V | no | Sollevamento/abbassamento / Raise/Lower | IP67 attacco - IP64 parte superiore | 0,3 | -25°C a 100°C | FENDT / FENDT G 816.860.100.201 | 55573 |

INTERRUTTORE A PULSANTE PNEUTRON

PNEUTRON PUSH BUTTON SWITCH
 INTERRUPTEUR À BOUTON PNEUTRON, SYMBOLE DE FLÈCHE
 PNEUTRON DRUCKTASTER, PFEILSYMBOL
 INTERRUPTOR DE BOTÓN PNEUTRON, SÍMBOLO DE FLECHA

| Skü | Brand / Brand | Tensione nominale / Rated voltage | Illuminazione / Lighting | Funzioni / Functions | Grado protezione ip / Degree of protection ip | Intensità di corrente / Current intensity | Temperatura di esercizio / Operating temperature | Descrizione / Description | Prodotti compatibili / Compatible products |
|---|---------------|-----------------------------------|--------------------------|------------------------------------|---|---|--|---|--|
|  55625 | Pneutron | 48 V | no | Sollevatore alzato / Hitch up | IP67 attacco - IP64 parte superiore | 0,5 | -25°C a 100°C | MASSEY FERGUSON, VALTRA / Massey Ferguson 4 284 628 M1, Massey Ferguson 4 270 313 M2, Valtra 36186100 | 55573 |
|  55626 | Pneutron | 48 V | no | Sollevatore abbassato / Hitch down | IP67 attacco - IP64 parte superiore | 0,5 | -25°C a 100°C | MASSEY FERGUSON, VALTRA / Massey Ferguson 4 284 627 M1, Massey Ferguson 4 270 312 M2, Valtra 36186000 | 55573 |
|  55627 | Pneutron | 48 V | no | Sollevatore abbassato / Hitch down | IP67 attacco - IP64 parte superiore | 0,5 | -25°C a 100°C | MASSEY FERGUSON / Massey Ferguson 3714138M1 | 55573 |
|  55628 | Pneutron | 48 V | no | Sollevatore alzato / Hitch up | IP67 attacco - IP64 parte superiore | 0,5 | -25°C a 100°C | MASSEY FERGUSON / Massey Ferguson 4 284 628 M2 | 55573 |
|  55629 | Pneutron | 48 V | no | Sollevatore abbassato / Hitch down | IP67 attacco - IP64 parte superiore | 0,5 | -25°C a 100°C | MASSEY FERGUSON / Massey Ferguson 4 284 627 M2 | 55573 |

| Skü | | Brand / Brand | Tensione nominale / Rated voltage | Illuminazione / Lighting | Funzioni / Functions | Grado protezione ip / Degree of protection ip | Intensità di corrente / Current intensity | Temperatura di esercizio / Operating temperature | Descrizione / Description | Prodotti compatibili / Compatible products |
|-------|--|---------------|-----------------------------------|--------------------------|---|---|---|--|---|--|
| 55630 | | Pneutron | 16 V | no | Sollevatore alzato / Hitch up | IP67 attacco - IP64 parte superiore | max 100 mA | -25°C a 100°C | CLAAS, RENAULT / Class 2158 218 0, Renault 77000 76 389 | 55573 |
| 55633 | | Pneutron | 16 V | no | Sollevatore abbassato / Hitch down | IP67 attacco - IP64 parte superiore | 100 mA | -25°C a 100°C | CLAAS, RENAULT / CLAAS 1091 050 1, 2158 219 0, Renault 77000 76 390 | 55573 |
| 55634 | | Pneutron | 16 V | no | Sollevatore alzato / Hitch up | IP67 attacco - IP64 parte superiore | max 100 mA | -25°C a 100°C | FENDT / FENDT G 716.861.100.040 | 55573 |
| 55635 | | Pneutron | 16 V | no | Sollevatore abbassato / Hitch down | IP67 attacco - IP64 parte superiore | max 100 mA | -25°C a 100°C | FENDT / FENDT G 716.861.100.030 | 55573 |
| 55638 | | Pneutron | 48 V | no | Sollevatore alzato / Hitch up | IP67 attacco - IP64 parte superiore | 0,5 | -25°C a 100°C | SAME, DEUTZ FAHR / SAME 2.7659.348.0, DEUTZ FAHR 2.7659.348.0 | 55573 |
| 55639 | | Pneutron | 48 V | no | Sollevatore alzato / Hitch up | IP67 attacco - IP64 parte superiore | 165 mA | -25°C a 100°C | CNH / CNH 47057241, CNH 1-40-558-048 | 55573 |
| 55643 | | Pneutron | 48 V | no | Sollevatore abbassato parte destra / Hitch down | IP67 attacco - IP64 parte superiore | 0,5 | -25°C a 100°C | SAME, DEUTZ FAHR / SAME 2.7659.347.0, DEUTZ FAHR 2.7659.347.0 | 55573 |
| 55644 | | Pneutron | 48 V | no | Sollevatore abbassato parte sinistra / Hitch down | IP67 attacco - IP64 parte superiore | 165 mA | -25°C a 100°C | CNH / CNH 47057242, CNH 1-40-558-047 | 55573 |
| 55645 | | Pneutron | 48 V | no | Sollevatore alzato / Hitch up | IP67 attacco - IP64 parte superiore | 0,5 | -25°C a 100°C | MERLO, CLAAS / MERLO 071 311, CLAAS 1089 420 1, CLAAS 2158 226 0 | 55573 |
| 55646 | | Pneutron | 48 V | no | Sollevatore abbassato / Hitch down | IP67 attacco - IP64 parte superiore | 0,5 | -25°C a 100°C | MERLO, CLAAS / MERLO 071 310, CLAAS 1089 419 1, CLAAS 2158 225 0 | 55573 |

INTERRUTTORI A PULSANTE PNEUTRON, PRESA DI FORZA PTO

PNEUTRON PUSH BUTTON SWITCHES, POWER TAKE-OFF (PTO)

INTERRUPTEURS À BOUTON PNEUTRON, PRISE DE FORCE (PTO)

PNEUTRON DRUCKTASTER, KRAFTABNEHMER (PTO)

INTERRUPTORES DE BOTÓN PNEUTRON, TOMA DE FUERZA (PTO)

| Skü | Brand / Brand | Funzioni / Functions | Tensione nominale / Rated voltage | Intensità di corrente / Current intensity | Connettore / Connector | Grado protezione ip / Degree of protection ip | Temperatura di esercizio / Operating temperature | Illuminazione / Lighting | Descrizione / Description | Prodotti compatibili / Compatible products |
|---|---------------|--|-----------------------------------|---|------------------------|---|--|--------------------------|--|--|
|  55647 | Pneutron | Presä di forza PTO / PTO | 48 V | 0,3 | AMP 3 poli | IP67 attacco - IP64 parte superiore | -25°C a 100°C | no | SAME, DEUTZ FAHR / SAME 2.7659.177.0/20, DEUTZ FAHR 2.7659.177.0/20 | 55573 |
|  55648 | Pneutron | Presä di forza PTO / PTO | 48 V | 0,5 | AMP 3 poli | IP67 attacco - IP64 parte superiore | -25°C a 100°C | no | JOHN DEERE, CLAAS / JOHN DEERE AL112561, CLAAS 0011 805.1 | 55573 |
|  55649 | Pneutron | Presä di forza PTO / PTO | 48 V | 0,5 | AMP 3 poli | IP67 attacco - IP64 parte superiore | -25°C a 100°C | no | JOHN DEERE, KRAMER, WACKER / JOHN DEERE AL208892, KRAMER 1000 335 101, WACKER 1000 335 101 | 55573 |
|  55650 | Pneutron | Presä di forza PTO ON/OFF / PTO ON/OFF | 48 V | 0,5 | AMP 3 poli | IP67 attacco - IP64 parte superiore | -25°C a 100°C | no | MASSEY FERGUSON, VALTRA / MASSEY FERGUSON 4 284 629 M1, MASSEY FERGUSON 4 271 992 M2, VALTRA 36483900 | 55573 |
|  55651 | Pneutron | Presä di forza PTO / PTO | 16 V | max 100 mA | AMP 3 poli | IP67 attacco - IP64 parte superiore | -25°C a 100°C | no | SAME, DEUTZ FAHR / SAME 04411533/10, SAME 2.7659.350.0, DEUTZ FAHR 4411533/10, DEUTZ FAHR 2.7659.350.0 | 55573 |
|  55652 | Pneutron | Presä di forza PTO / PTO | 48 V | max 20 mA | AMP 3 poli | IP67 attacco - IP64 parte superiore | -25°C a 100°C | no | CNH / CNH 82016444 | 55573 |
|  55653 | Pneutron | Presä di forza PTO / PTO | 16 V | max 100 mA | AMP 3 poli | IP67 attacco - IP64 parte superiore | -25°C a 100°C | no | FENDT / FENDT G 312.970.090.011 | 55573 |
|  55654 | Pneutron | Presä di forza PTO / PTO | 48 V | 0,5 | AMP 3 poli | IP67 attacco - IP64 parte superiore | -25°C a 100°C | no | CNH / CNH 82025543 | 55573 |
|  55655 | Pneutron | Presä di forza PTO, stop / PTO Stop | 70 V | 0,5 | AMP 3 poli | IP67 attacco - IP64 parte superiore | -25°C a 100°C | no | CLAAS, RENAULT / CLAAS 2158 217 0, CLAAS 77000 38 690, RENAULT 2158 217 0, RENAULT 77000 38 690 | 55573 |

INTERRUTTORI A PULSANTE

PNEUTRON PUSH-BUTTON SWITCHES

INTERRUPTEURS À BOUTON-POUSSOIR PNEUTRON

PNEUTRON-DRUCKTASTER

INTERRUPTORES DE BOTÓN PULSADOR PNEUTRON

Articoli a ricambio

I36104 Blocchetto per interruttore Pneutron

| Skü | Brand / Brand | Funzioni / Functions | Tensione nominale / Rated voltage | Grado protezione ip / Degree of protection ip | Note / Notes | |
|---------------|---|----------------------|--------------------------------------|--|--------------|---|
| I36006 |  | Pneutron | Emergenza / Hazard | 12 V | IP67 | Art. I36104 Connettore non incluso / Art. I36104 connector not included |
| I36007 |  | Pneutron | Lampada rotante / Rotating beacon | 12 V | IP67 | Art. I36104 Connettore non incluso / Art. I36104 connector not included |
| I36010 |  | Pneutron | Emergenza / Hazard | 24 V | IP67 | Art. I36104 Connettore non incluso / Art. I36104 connector not included |
| I36011 |  | Pneutron | Faro da lavoro / Work light | 12 V | IP67 | Art. I36104 Connettore non incluso / Art. I36104 connector not included |
| I36012 |  | Pneutron | Freno parcheggio / Parking brake | 12 V | IP67 | Art. I36104 Connettore non incluso / Art. I36104 connector not included |
| I36013 |  | Pneutron | Freccia / Turn indicator | 12 V | IP67 | Art. I36104 Connettore non incluso / Art. I36104 connector not included |
| I36015 |  | Pneutron | Neutro / Neutral | 12 V | IP67 | Art. I36104 Connettore non incluso / Art. I36104 connector not included |
| I36022 |  | Pneutron | Clacson | 12 V | IP67 | Art. I36104 Connettore non incluso / Art. I36104 connector not included |

INTERRUTTORI A PULSANTE D'EMERGENZA LUMINOSO 12V COMPATIBILE NH 5122659

ILLUMINATED EMERGENCY PUSH BUTTON SWITCHES 12V, COMPATIBLE WITH NH 5122659

INTERRUPTEURS D'ARRÊT D'URGENCE LUMINEUX 12V, COMPATIBLES AVEC NH 5122659

LEUCHTENDE NOT-AUS-DRUCKTASTER 12V, PASSEND FÜR NH 5122659

INTERRUPTORES DE BOTÓN DE EMERGENCIA ILUMINADOS 12V, COMPATIBLES CON NH 5122659



| Skü | Funzioni / Functions | Illuminazione / Lighting | Intensità di corrente / Current intensity | Tensione nominale / Rated voltage | Contatti elettrici / Electrical contacts | Diametro di foratura / Drilling diameter | Temperatura di esercizio / Operating temperature |
|-------|----------------------|--------------------------|---|-----------------------------------|--|--|--|
| 14446 | Emergenza / Hazard | presente / available | 14A - 12V; 7A - 24V | 12V | faston 6,3x0,8 | 28,4 mm | -40°C a +50°C |

PULSANTE AVVIAMENTO

START BUTTON

BOUTON DE DÉMARRAGE

ANLASSERDRUCKKNOPF

PULSADOR DEL ARRANQUE



| Skü | Tensione nominale / Rated voltage | Funzioni / Functions | Diametro di foratura / Drilling diameter | Grado protezione ip / Degree of protection ip | Temperatura di esercizio / Operating temperature | Note / Notes |
|-------|-----------------------------------|----------------------|--|---|--|---|
| 00083 | 12-24 V | ON-OFF | 22,5 mm | IP66 frontale | -40° / +90° C | Intercambiabile Cobo 17.153.000. Riferimenti originali: Fiat CNH 5127282; Fiat CNH 2050622; Same S.3050.0022. |

INTERRUTTORE A PULSANTE PER AVVISATORE ACUSTICO

PUSH BUTTON SWITCH FOR HORN

INTERRUPTEUR À BOUTON POUR AVERTISSEUR SONORE

DRUCKTASTER FÜR SIGNALHORN

INTERRUPTOR DE BOTÓN PARA AVISADOR ACÚSTICO



| Skü | Tensione nominale / Rated voltage | Carico max 12V / Max. load 12V | Carico max 24V / Max. load 24V | Contatti elettrici / Electrical contacts | Diametro di foratura / Drilling diameter |
|-------|-----------------------------------|--------------------------------|--------------------------------|--|--|
| 00459 | 12-24V | 20 A | 15 A | faston 6,3 mm | 21,4 mm |

PULSANTE AVVISATORE ACUSTICO



HORN BUTTON
 BOUTON D'AVERTISSEUR SONORE
 HUPKNOPF
 BOTÓN DE CLAXON



| Sku | Brand / Brand | Tensione nominale / Rated voltage | Funzioni / Functions | Carico max 12V / Max. load 12V | Carico max 24V / Max. load 24V | Contatti elettrici / Electrical contacts | Diametro di foratura / Drilling diameter | Grado protezione ip / Degree of protection ip | Temperatura di esercizio / Operating temperature |
|-------|---------------|-----------------------------------|----------------------------|--------------------------------|--------------------------------|--|--|---|--|
| 59703 | Cobo | 12-24 V | Avvisatore acustico / Horn | 25A | 25A | faston 6,3 mm | 22,5 mm | IP40 | -20° / +40° C |

PULSANTI DI MASSA



BATTERY DISCONNECT SWITCHES
 INTERRUPTEURS DE DÉCONNEXION DE MASSE
 MASSE-SCHALTER
 INTERRUPTORES DE DESCONEXIÓN DE MASA

| Sku | Descrizione / Description |
|-------|---|
| 02093 |  Pulsante di massa cromato con attacco a vite / Ground button with screw terminal |
| 55335 |  Pulsante di massa con attacco a fascetta per manubrio 7/8" o 1", cavo lungo 120 cm. / Kill switch, fits all 7/8 or 1" handles, wire 120 cm. |

PULSANTE ARRESTO EMERGENZA

EMERGENCY STOP BUTTON
 INTERRUPTEUR D'ARRÊT D'URGENCE
 NOT-AUS SCHALTER
 BOTÓN DE PARADA DE EMERGENCIA

Articoli a ricambio

| | |
|---|---|
|  | 09868 Corpo pulsante |
|  | TE.903 Etichetta arresto d'emergenza |

| Sku | Diametro di foratura / Drilling diameter | Dimensioni / Dimensions | Grado protezione ip / Degree of protection ip | Temperatura di esercizio / Operating temperature |
|-------|--|--|---|--|
| 09867 | 22 mm | Cappuccio rosso Ø 40mm / Red cap Ø 40 mm | IP66 | -25° / +70° C |

PULSANTIERA CON FUNGO DI EMERGENZA

EMERGENCY STOP PUSH BUTTON BOX
 BOUTON POUSSOIR.D'ARRET D'URGENCE
 NOT-AUS SCHALTERGEHÄUSE
 CAJA DE PULSADOR PARADA DE EMERGENCIA



| Skù | Tensione nominale / Rated voltage | Specifiche / Specifications | Dimensioni / Dimensions | Note / Notes | Grado protezione ip / Degree of protection ip | Temperatura di esercizio / Operating temperature |
|-------|-----------------------------------|---|--|--|---|--|
| 55325 | 12-24 V | aggancio/sgancio a rotazione / twist-on / twist-off | Pulsantiera 70x70x83 mm; Pulsante Ø 40 mm / Push button panel 70x70x83 mm; Push button Ø 40 mm | con elemento di contatto NC/ with NC contact element | IP65 | -25° / + 70° C |

INTERRUTTORI A PULSANTE PER BLOCCO AVVIAMENTO

PUSH-BUTTON SWITCH FOR START BLOCKING
 INTERRUPTEUR À BOUTON-POUSSOIR POUR BLOCAGE DE DÉMARRAGE
 DRUCKTASTENSCHALTER FÜR STARTBLOCKIERUNG
 INTERRUPTOR DE BOTÓN PULSADOR PARA BLOQUEO DE ARRANQUE



| Skù | Tensione nominale / Rated voltage | Carico max 12V / Max. load 12V | Carico max 24V / Max. load 24V | Passo / Pitch | Filettatura maschio / Male threading | Contatti elettrici / Electrical contacts | Grado protezione ip / Degree of protection ip | Temperatura di esercizio / Operating temperature | Connettore / Connector |
|--------|-----------------------------------|--------------------------------|--------------------------------|---------------|--------------------------------------|--|---|--|--|
| I15010 | 12-24 V | 25A | 15A | 1,5 | M16 | 4 | IP67 | -20° / +40° C | Per connessione: art. 01880 Faston femmina 0,5-2 e art. 02581 cappuccio coprifaston / Connection with Art. 01880 female Faston 0.5-2 and Art. 02581 Faston cap |

INTERRUTTORE LUCI DI EMERGENZA

SWITCH FOR HAZARD LIGHTS
 INTERRUPTEUR POUR FEUX DE DÉTRESSE
 DRUCKTASTER FÜR WARNBLINKANLAGE
 INTERRUPTOR PARA LUCES DE EMERGENCIA



| Skù | Tensione nominale / Rated voltage | Intensità di corrente / Current intensity | Contatti elettrici / Electrical contacts |
|---------------|-----------------------------------|---|--|
| V2.8639.002.0 | 12-24 V | 5-10 A | NC/NO/scambio |

INTERRUTTORI BASCULANTI



ROCKER SWITCHES







INTERRUPTEURS À BASCULE

WIPPSCHALTER

INTERRUPTORES BASCULANTES

Articoli a ricambio

| | | | |
|---|--------------|-----------------------------|-------|
|  | 59053 | Tappo copri-foro basculante | 59058 |
|  | 59056 | Mostrina per 3 interruttori | 59058 |

| Skù | Tensione nominale / Rated voltage | Funzioni / Functions | Illuminazione / Lighting | Modello / Model | Dimensioni / Dimensions |
|--|-----------------------------------|--|--------------------------|-----------------|-------------------------|
|  59058 | 12 V | Indicatore di direzione / Turn indicator | presente / available | ON-OFF-ON | 500x260x430 |
|  59059 | 12 V | Freno a mano / Handbrake | presente / available | ON-OFF | 500x260x430 |
|  59060 | 12 V | Emergenza / Hazard lights | presente / available | ON-OFF | 500x260x430 |
|  59061 | 12 V | Lampada rotante / Rotating beacon | presente / available | ON-OFF | 500x260x430 |
|  59062 | 12 V | Tergicristalli / Wipers | presente / available | ON-OFF | 500x260x430 |
|  59064 | 12 V | Luce di posizione / Position light | presente / available | OFF-ON-ON | 500x260x430 |
|  59065 | 12 V | Anabbagliante / Low beam | presente / available | ON-OFF | 500x260x430 |
|  59066 | 12 V | Abbagliante / High beam | presente / available | ON-OFF | 500x260x430 |

DEVIOFRECCCE

TURN SIGNAL SWITCH
 COMMODO DE CLIGNOTANTS
 BLINKERSCHALTER
 INTERRUPTOR DE INTERMITENTES

| Skü | Brand / Brand | Funzioni / Functions | Grado protezione ip / Degree of protection ip | Contatti elettrici / Electrical contacts | Diametro di foratura / Drilling diameter | Tensione nominale / Rated voltage |
|--------------|---------------|--|---|--|--|-----------------------------------|
| 01355 | Ama | Freccia sx - OFF - Freccia dx / Left indicator - OFF - Right indicator | IP 53 | 3 | 22,5 mm | 12/24 V |
| 10040 | Cobo | Freccia sx - OFF - Freccia dx / Left indicator - OFF - Right indicator | IP 53 | 3 | 19,9 + 20 mm | 12/24 V |
| 11256 | Cobo | Freccia sx - OFF - Freccia dx + lampeggio / Left indicator - OFF - Right indicator + hazard lights | IP53 | 5 contatti | 22.5 mm | 12/24 V |

DEVIOFRECCCE

TURN SIGNAL SWITCH
 COMMODO DE CLIGNOTANTS
 BLINKERSCHALTER
 INTERRUPTOR DE INTERMITENTES



| Skü | Brand / Brand | Funzioni / Functions | Tensione nominale / Rated voltage | Diametro piantone / Pivot diameter |
|----------------|---------------|--|-----------------------------------|------------------------------------|
| 0D12310 | Ama | Freccia dx, freccia sx, clacson / Rh turn signal, Lh turn signal, horn | 12-24 V | 45 mm |

DEVIO LUCI

LIGHT SWITCH
 COMMUTATEUR DE FEUX
 LICHTSCHALTER
 COMMUTADOR DE LUCES



| Skü | Brand / Brand | Funzioni / Functions | Tensione nominale / Rated voltage | Diametro piantone / Pivot diameter |
|----------------|---------------|---|-----------------------------------|------------------------------------|
| 0D12144 | Valeo | Anabbaglianeti, abbaglianti, lampeggio, frecce, clacson / Low beam, high beam, flashing, turn signals, horn | 12-24 V | 45 mm |

DEVIO LUCI

 LIGHT SWITCH
 COMMUTATEUR DE FEUX
 LICHTSCHALTER
 COMMUTADOR DE LUCES

| Skü | Funzioni / Functions | Tensione nominale / Rated voltage | Brand / Brand | Diametro piantone / Pivot diameter |
|----------------|---|-----------------------------------|---------------|------------------------------------|
| 0D12171 | Anabbaglianti, abbaglianti, lampeggio, frecce, clacson / Low beam, high beam, flashing, turn signal, horn | 12-24 V | Valeo | 45 mm |

DEVIO LUCI

 LIGHT SWITCH
 COMMUTATEUR DE FEUX
 LICHTSCHALTER
 COMMUTADOR DE LUCES

| Skü | Funzioni / Functions | Tensione nominale / Rated voltage | Brand / Brand | Diametro piantone / Pivot diameter |
|----------------|--|-----------------------------------|---------------|------------------------------------|
| 0D12165 | Abbaglianti, anabbaglianti, lampeggio, clacson, frecce, lavacrystallo, 1° velocità tergi, 2° velocità tergi / High beam, low beam, headlight flasher, horn, turn signals, windshield washer, low wiper speed, high wiper speed | 12-24 V | Valeo | 45 mm |

DEVIO LUCI CON FISSAGGIO A CRUSCOTTO

 LIGHT SWITCH WITH DASHBOARD MOUNTING
 COMMUTATEUR D'ÉCLAIRAGE AVEC FIXATION AU TABLEAU DE BORD
 LICHTSCHALTER MIT ARMATURENBRETTBEFESTIGUNG
 INTERRUPTOR DE LUCES CON FIJACIÓN AL SALPICADERO

| Skü | Funzioni / Functions | Tensione nominale / Rated voltage | Brand / Brand |
|--------------|--|-----------------------------------|---------------|
| 00899 | Clacson, anabbagliante, abbagliante, lampeggio, frecce / Horn, lights, flash light, turn indicator | 12-24 V | Cobo |

DEVIO MARCE

GEAR SELECTOR SWITCH
 COMMUTEUR DE VITESSE
 GANGWAHLSCHALTER
 COMMUTADOR DE MARCHAS



| Skü | Funzioni / Functions | Tensione nominale / Rated voltage | Brand / Brand | Diametro piantone / Pivot diameter | Note / Notes |
|----------------|---|--------------------------------------|------------------|---------------------------------------|---|
| 0D12162 | Marcia avanti con sicurezza, marcia indietro con sicurezza, cambio velocità 1-2 / Safe forward drive, safe reverse drive, speed shift 1-2 | 12-24 V | Valeo | 45 mm | Art. 0D12134.C-2 kit staffa di fissaggio, non inclusa / Art. 0D12134.C-2 mounting bracket kit, not included |

QUADRO AVVIAMENTO 0-1

IGNITION SWITCH 0-1
 CONTACTEUR DE DÉMARRAGE 0-1
 ZÜNDSCHALTER 0-1
 INTERRUPTOR DE ENCENDIDO 0-1



| | |
|----------|---------------------|
| 0 | OFF |
| 1 | Servizi Services |

Articoli a ricambio



Q13010.P Chiave di accensione 2 pz

| Skü | Diametro di foratura / Drilling diameter |
|--------------|--|
| 04058 | 22,5 mm |

QUADRO AVVIAMENTO

IGNITION SWITCH
 CONTACTEUR DE DÉMARRAGE
 ZÜNDSCHALTER
 INTERRUPTOR DE ENCENDIDO



| | |
|----------|---|
| 0 | OFF |
| 1 | Servizi Services |
| 2 | Avviamento (con antiripetizione) Starting |

Articoli a ricambio



57686 Chiave di accensione

| Skü | Diametro di foratura / Drilling diameter |
|--------------|--|
| 63066 | 26,5 mm |

QUADRO AVVIAMENTO 0-1-2

IGNITION SWITCH 0-1-2
 CONTACTEUR DE DÉMARRAGE 0-1-2
 ZÜNDSCHALTER 0-1-2
 INTERRUPTOR DE ENCENDIDO 0-1-2



| | |
|---|------------------------|
| 0 | OFF |
| 1 | Servizi Services |
| 2 | Avviamento Starting |

Articoli a ricambio

00546 Chiave di accensione

Sku
Diametro di foratura / Drilling diameter

04158 22,5 mm

QUADRO AVVIAMENTO 0-1-2

IGNITION SWITCH 0-1-2
 CONTACTEUR DE DÉMARRAGE 0-1-2
 ZÜNDSCHALTER 0-1-2
 INTERRUPTOR DE ENCENDIDO 0-1-2



| | |
|---|------------------------|
| 0 | OFF |
| 1 | Servizi Services |
| 2 | Avviamento Starting |

Articoli a ricambio

00546 Chiave di accensione

Sku
Diametro di foratura / Drilling diameter

69584 22,5 mm

QUADRO AVVIAMENTO 0-1-P-2

IGNITION SWITCH 0-1-P-2
 CONTACTEUR DE DÉMARRAGE 0-1-2
 ZÜNDSCHALTER 0-1-2
 INTERRUPTOR DE ENCENDIDO 0-1-2



| | |
|---|--------------------------------|
| 0 | OFF |
| 1 | Servizi Services |
| P | Preriscaldamento Preheating |
| 2 | Avviamento Starting |

Sku
Diametro di foratura / Drilling diameter

69585 22,5 mm

QUADRO AVVIAMENTO 0-1-2

IGNITION SWITCH 0-1-2
 CONTACTEUR DE DÉMARRAGE 0-1-2
 ZÜNDSCHALTER 0-1-2
 INTERRUPTOR DE ENCENDIDO 0-1-2



| | |
|---|------------------------|
| 0 | OFF |
| 1 | Servizi Services |
| 2 | Avviamento Starting |

Skü

Diametro di foratura / Drilling diameter

12333

22,5 mm

QUADRO AVVIAMENTO

IGNITION SWITCH
 CONTACTEUR DE DÉMARRAGE
 ZÜNDSCHALTER
 INTERRUPTOR DE ARRANQUE



| | |
|---|------------------------|
| 0 | OFF |
| 1 | Servizi Services |
| 2 | Avviamento Starting |

Skü

Diametro di foratura / Drilling diameter

63068

22,5 mm

QUADRO AVVIAMENTO

IGNITION SWITCH
 CONTACTEUR DE DÉMARRAGE
 ZÜNDSCHALTER
 INTERRUPTOR DE ARRANQUE



| | |
|---|---|
| 0 | OFF |
| 1 | Servizi Services |
| 2 | Avviamento (senza antiripetizione) Starting |

Articoli a ricambio



63069 Chiave di accensione

Skü

Diametro di foratura / Drilling diameter

63067

26,5 mm

QUADRO AVVIAMENTO CON PRERISCALDO

IGNITION SWITCH WITH PREHEATING
 CONTACTEUR DE DÉMARRAGE AVEC PRÉCHAUFFAGE
 ZÜNDSCHALTER MIT VORHEIZUNG
 INTERRUPTOR DE ENCENDIDO CON PRECALENTAMIENTO



| | |
|---|--------------------------------|
| 0 | OFF |
| 1 | Servizi Services |
| 2 | Preriscaldamento Preheating |
| 3 | Avviamento Starting |

Sku
Diametro di foratura / Drilling diameter
41981

16x14,1 mm

QUADRO AVVIAMENTO

IGNITION SWITCH
 CONTACTEUR DE DÉMARRAGE
 ZÜNDSCHALTER
 INTERRUPTOR DE ENCENDIDO



| | |
|---|---|
| 0 | OFF |
| 1 | Servizi Services |
| 2 | Preriscaldamento Preheating |
| 3 | Avviamento (con antiripetizione) Starting |

Articoli a ricambio

62491 Chiave di accensione

Sku
Diametro di foratura / Drilling diameter
60129

26,5 mm

QUADRO AVVIAMENTO CON PRERISCALDO CON 4 POSIZIONI CHIAVE

IGNITION SWITCH WITH PREHEATING, 4 KEY POSITIONS
 CONTACTEUR DE DÉMARRAGE AVEC PRÉCHAUFFAGE, 4 POSITIONS DE CLÉ
 ZÜNDSCHALTER MIT VORHEIZUNG, 4 SCHLÜSSELPOSITIONEN
 INTERRUPTOR DE ENCENDIDO CON PRECALENTAMIENTO, 4 POSICIONES DE LLAVE



| | |
|---|--------------------------------|
| P | Preriscaldamento Preheating |
| 0 | OFF |
| 1 | Servizi Services |
| 2 | Avviamento Starting |

Articoli a ricambio

00546 Chiave di accensione

Sku
Diametro di foratura / Drilling diameter
01397

22,5 mm

QUADRO AVVIAMENTO

IGNITION SWITCH
CONTACTEUR DE DÉMARRAGE
ZÜNDSCHALTER
INTERRUPTOR DE ENCENDIDO



| | |
|----------|--|
| P | Preriscaldamento <i>Preheating</i> |
| 0 | OFF |
| 1 | Servizi <i>Services</i> |
| 2 | Avviamento <i>Starting</i> |

Articoli a ricambio



00546 Chiave di accensione

Sku

Diametro di foratura / Drilling diameter

69586 22,5 mm

QUADRO AVVIAMENTO

IGNITION SWITCH
CONTACTEUR DE DÉMARRAGE
ZÜNDSCHALTER MIT VORHEIZUNG
INTERRUPTOR DE ENCENDIDO



| | |
|----------|--|
| P | Luci Parcheggio <i>Parking</i> |
| 0 | OFF |
| 1 | Servizi <i>Services</i> |
| 2 | Avviamento <i>Starting</i> |

Articoli a ricambio



00546 Chiave di accensione

Sku

Diametro di foratura / Drilling diameter

00769 22,5 mm

QUADRO AVVIAMENTO

IGNITION SWITCH
CONTACTEUR DE DÉMARRAGE
ZÜNDSCHALTER
INTERRUPTOR DE ARRANQUE



| | |
|----------|--|
| P | Luci Parcheggio <i>Parking</i> |
| 0 | OFF |
| 1 | Servizi <i>Services</i> |
| 2 | Avviamento <i>Starting</i> |

Articoli a ricambio



62497 Chiave di accensione

Sku

Diametro di foratura / Drilling diameter

62496 25,5 mm

QUADRO AVVIAMENTO

 IGNITION SWITCH
 CONTACTEUR DE DÉMARRAGE
 ZÜNDSCHALTER
 INTERRUPTOR DE ARRANQUE

| | |
|----------|--|
| P | Luci Parcheggio <i>Parking</i> |
| 0 | OFF |
| 1 | Servizi <i>Services</i> |
| 2 | Avviamento <i>(con antiripetizione)</i> <i>Starting</i> |

Articoli a ricambio

00546 Chiave di accensione

Sku
Diametro di foratura / Drilling diameter
69583

22,5 mm

QUADRO AVVIAMENTO

 IGNITION SWITCH
 CONTACTEUR DE DÉMARRAGE
 ZÜNDSCHALTER
 INTERRUPTOR DE ARRANQUE

| | |
|----------|--|
| P | Luci Parcheggio <i>Parking</i> |
| 0 | OFF |
| 1 | Servizi <i>Services</i> |
| 2 | Avviamento <i>(con antiripetizione)</i> <i>Starting</i> |

Articoli a ricambio

00546 Chiave di accensione

Sku
Diametro di foratura / Drilling diameter
69582

22,5 mm

QUADRO AVVIAMENTO

 IGNITION SWITCH
 CONTACTEUR DE DÉMARRAGE
 ZÜNDSCHALTER
 INTERRUPTOR DE ENCENDIDO

| | |
|----------|--|
| P | Luci Parcheggio <i>Parking</i> |
| 0 | OFF |
| 1 | Servizi <i>Services</i> |
| 2 | Preriscaldamento <i>Preheating</i> |
| 3 | Avviamento <i>(senza antiripetizione)</i> <i>Starting</i> |

Articoli a ricambio

57686 Chiave di accensione

Sku
Diametro di foratura / Drilling diameter
57685

26,6 mm

QUADRI AVVIAMENTO

IGNITION SWITCHES
CONTACTEURS DE DÉMARRAGE
ZÜNDSCHALTER
INTERRUPTORES DE ARRANQUE



| | |
|----------|---|
| P | Luci Parcheggio <i>Parking</i> |
| 0 | OFF |
| 1 | Servizi <i>Services</i> |
| 2 | Preriscaldamento <i>Preheating</i> |
| 3 | Avviamento <i>(con antiripetizione)</i> <i>Starting</i> |

Articoli a ricambio



62491 Chiave di accensione

| | |
|--------------|---|
| Sku | Diametro di foratura / Drilling diameter |
| 62490 | 26,5 mm |

QUADRO AVVIAMENTO

IGNITION SWITCH
CONTACTEUR DE DÉMARRAGE
ZÜNDSCHALTER
INTERRUPTOR DE ENCENDIDO



| | |
|----------|---|
| P | Luci Parcheggio <i>Parking</i> |
| 0 | OFF |
| 1 | Servizi <i>Services</i> |
| 2 | Preriscaldamento <i>Preheating</i> |
| 3 | Avviamento <i>(con antiripetizione)</i> <i>Starting</i> |

Articoli a ricambio



57686 Chiave di accensione

| | |
|--------------|---|
| Sku | Diametro di foratura / Drilling diameter |
| 60139 | 26,5 mm |

QUADRO LUCE

LIGHT SWITCH
COMMODO D'ÉCLAIRAGE
LENKSTOCKSCHALTER
CONMUTADOR DE LUCES



| | |
|----------|--|
| 0 | OFF |
| 1 | Luci di Posizione <i>Position light</i> |
| 2 | Luci anabbaglianti <i>Low beam</i> |
| 3 | Luci abbaglianti <i>High beam</i> |

| | | |
|--------------|----------------------|---|
| Sku | Brand / Brand | Diametro di foratura / Drilling diameter |
| 00413 | Cobo | 22,5 mm |

QUADRO LUCE

 LIGHT SWITCH
 COMMODO D'ÉCLAIRAGE
 LENKSTOCKSCHALTER
 CONMUTADOR DE LUCES

| | |
|----------|---|
| P | Luci parcheggio <i>Parking light</i> |
| 0 | OFF |
| 1 | Luci di posizione <i>Position light</i> |
| 2 | Luci anabbaglianti <i>Low beam</i> |
| 3 | Luci abbaglianti <i>High beam</i> |

Articoli a ricambio

00545

 CHIAVE DI ACCENSIONE ADATTA PER
 FIAT

Sku
Diametro di foratura / Drilling diameter
00453

22,5 mm

COMMUTATORE LUCI

 LIGHT SELECTOR SWITCH
 COMMUTEUR DE LUMIÈRES
 LICHTUMSCHALTER
 CONMUTADOR DE LUCES

| | |
|-------------|---|
| 0 | OFF |
| 1 | Luci di Posizione <i>Position light</i> |
| 2 | Luci anabbaglianti <i>Low beam</i> |
| 3 | Luci abbaglianti <i>High beam</i> |
| Push | Clacson <i>Horn</i> |

Sku
Diametro di foratura / Drilling diameter
00414

22,5 mm

COMMUTATORE LUCI

 LIGHT SELECTOR SWITCH
 COMMUTEUR DE LUMIÈRES
 LICHTUMSCHALTER
 CONMUTADOR DE LUCES

| | |
|-------------|---|
| 0 | OFF |
| 1 | Luci di Posizione <i>Position light</i> |
| 2 | Luci anabbaglianti <i>Low beam</i> |
| 3 | Luci abbaglianti <i>High beam</i> |
| Push | Clacson <i>Horn</i> |

Sku
Diametro di foratura / Drilling diameter
00455

22,5 mm













Lampadine













Bulbs











I prodotti recanti il marchio AMA qui indicati sono realizzati da AMA S.p.A. e destinati a essere utilizzati come ricambi adattabili e non originali. I riferimenti a marchi, codici originali e costruttori di terzi, riportati in corrispondenza degli articoli AMA compatibili, hanno esclusivamente la finalità di identificare il modello, l'applicazione o la destinazione d'uso del prodotto, in conformità a quanto previsto dal Regolamento (CE) n. 1400/2002 e dalla normativa vigente in materia di concorrenza e uso lecito dei marchi di terzi. / The products bearing the AMA brand name listed here are manufactured by AMA S.p.A. and are intended for use as adaptable, non-original spare parts. References to trademarks, original codes and third-party manufacturers, shown alongside compatible AMA items, are intended solely to identify the model, application or intended use of the product, in accordance with Regulation (EC) No. 1400/2002 and current legislation on competition and the lawful use of third-party trademarks.

LAMPADINE ALOGENE

 HALOGEN BULBS
 AMPOULES HALOGÈNES
 HALOGENLAMPEN
 BOMBILLAS HALÓGENAS

| Skü | Modello / Model | Tensione nominale / Rated voltage | Potenza nominale / Rated power | Attacco out / Attack out |
|-----------------|---|-----------------------------------|--------------------------------|--------------------------|
| 26049 |  Per spia / For warning lights | 12 V | 1 W | faston 6,3x0,8 |
| 26050 |  Per spia / For warning lights | 24 V | 1 W | faston 6,3x0,9 |
| L26031.0 |  T5 | 12 V | 1,2 W | W2x4,6d |
| 00324 |  BA7s | 12 V | 2 W | BA7s |
| 00451 |  T3W | 12 V | 3 W | BA9s |
| 00525 |  T3W | 24 V | 3 W | BA9s |
| 00398 |  W3W | 12 V | 3 W | W2,1x9,5d |
| 00277 |  C5W | 12 V | 5 W | SV8,5 |
| 00526 |  C5W | 24 V | 5 W | SV8,5-8 |
| 00397 |  R5W | 12 V | 5 W | BA15s |

| Skü | Modello / Model | Tensione nominale / Rated voltage | Potenza nominale / Rated power | Attacco out / Attack out |
|--------|--|-----------------------------------|--------------------------------|--------------------------|
| 00524 |  R5W | 24 V | 5 W | BA15s |
| 56896 |  W5W | 12 V | 5 W | W2,1x9,5d |
| 12581 |  C10W | 12 V | 10 W | SV8,5-8 |
| 03874 |  R10W | 12 V | 10 W | BA15s |
| 00440 |  P21/5W | 12 V | 21/5 W | BAY15d |
| 00501 |  P21/5W | 24 V | 21/5 W | BAY15d |
| 00441 |  P21W | 12 V | 21 W | BA15s |
| 04019 |  P21W | 24 V | 21 W | BA15s |
| 26065 |  H27W12 | 12 V | 27 W | PGJ13 |
| 00295 |  R2 | 12 V | 45/40 W | P45t |
| L26012 |  R2 | 24 V | 55/50 W | P45t |
| 00439 |  S2 | 12 V | 45/40 W | BA20d |

| Sku | Modello / Model | Tensione nominale / Rated voltage | Potenza nominale / Rated power | Attacco out / Attack out |
|--------------|--|--|---------------------------------------|---------------------------------|
| 00391 |  S2 | 24 V | 50/45 W | BA20d |
| 00278 |  B11 | 12 V | 50 W | BA20s |
| 00299 |  H3 | 12 V | 55 W | PK22s |
| 00446 |  H3 | 24 V | 70 W | PK22s |
| 55385 |  HB4 | 12 V | 51 W | P22d |
| 08048 |  H1 | 12 V | 55 W | P14,5s |
| 08049 |  H1 | 24 V | 70 W | P14,5s |
| 00373 |  H4 | 12 V | 60/55 W | P43t |
| 61529 |  H4 | 12 V | 60/55 W | P45t |
| 12629 |  H4 | 24 V | 60/55 W | P45t |
| 00375 |  H4 | 24 V | 75/70 W | P43t |

ESPOSITORE LAMPADINE







HALOGEN BULBS DISPLAY
 PRÉSENTOIR POUR AMPOULES HALOGÈNES
 HALOGENLAMPEN-AUSSTELLER
 EXPOSITOR DE BOMBILLAS HALÓGENAS









| Skü | Altezza / Height | Lunghezza / Length | Larghezza / Width | Contenuto / Content |
|------------------------|------------------|--------------------|-------------------|---------------------|
| WCT-ESPLAMPADIN | 920 mm | 660 mm | 600 mm | 16 ganci / 16 hooks |

LAMPADINE ALOGENE BLISTER



HALOGEN BULBS IN BLISTER PACK
 AMPOULES HALOGÈNES EN BLISTER
 HALOGENLAMPEN IM BLISTERPACK
 BOMBILLAS HALÓGENAS EN BLISTER











| Skü | Modello / Model | Tensione nominale / Rated voltage | Potenza nominale / Rated power | Attacco out / Attack out | Confezionamento / Packaging |
|---------------|--|-----------------------------------|--------------------------------|--------------------------|-----------------------------|
| 00451C |  T3W | 12 V | 3 W | BA9s | Blister 2 pz |
| 00398C |  W3W | 12 V | 3 W | W2,1x9,5d | Blister 2 pz |
| 00277C |  C5W | 12 V | 5 W | SV8,5 | Blister 2 pz |
| 00397C |  R5W | 12 V | 5 W | BA15s | Blister 2 pz |
| 12581C |  C10W | 12 V | 10 W | SV8,5-8 | Blister 2 pz |
| 03874C |  R10W | 12 V | 10 W | BA15s | Blister 2 pz |
| 00440C |  P21/5W | 12 V | 21/5 W | BAY15d | Blister 2 pz |

| Skü | Modello / Model | Tensione nominale / Rated voltage | Potenza nominale / Rated power | Attacco out / Attack out | Confezionamento / Packaging |
|---------------|--|-----------------------------------|--------------------------------|--------------------------|-----------------------------|
| 00441C |  P21W | 12 V | 21 W | BA15s | Blister 2 pz |
| 00295C |  R2 | 12 V | 45/40 W | P45t | Box appendibile 1 pz |
| 00439C |  S2 | 12 V | 45/40 W | BA20d | Box appendibile 1 pz |
| 00299C |  H3 | 12 V | 55 W | PK22s | Blister 1 pz |
| 08048C |  H1 | 12 V | 55 W | P14,5s | Blister 1 pz |
| 56904C |  H7 | 12 V | 55 W | PX26d | Blister 1 pz |
| 00373C |  H4 | 12 V | 60/55 W | P43t | Blister 1 pz |

LAMPADINE OSRAM ALOGENE

OSRAM HALOGEN BULBS
OSRAM AMPOULES HALOGÈNES
OSRAM HALOGENLAMPEN
OSRAM BOMBILLAS HALÓGENAS

| Skü | Modello / Model | Tensione nominale / Rated voltage | Potenza nominale / Rated power | Attacco out / Attack out |
|--------------|---|-----------------------------------|--------------------------------|--------------------------|
| 34511 |  W3W | 12 V | 3 W | W2,1x9,5d |
| 34514 |  C5W | 12 V | 5 W | SV8,5 |
| 34508 |  R5W | 12 V | 5 W | BA15s |

| Skü | Modello / Model | Tensione nominale / Rated voltage | Potenza nominale / Rated power | Attacco out / Attack out |
|-------|--|-----------------------------------|--------------------------------|--------------------------|
| 64433 |  W5W | 12 V | 5 W | W2,1x9,5d |
| 34509 |  R10W | 12 V | 10 W | BA15s |
| 34507 |  P21/5W | 12 V | 21/5 W | BAY15d |
| 34505 |  P21W | 12 V | 21 W | BA15s |
| 34517 |  H3 | 12 V | 55 W | PK22s |
| 34528 |  H3 | 24 V | 70 W | PK22s |
| 34516 |  H1 | 12 V | 55 W | P14,5s |
| 34536 |  H7 | 12 V | 55 W | PX26d |
| 34518 |  H4 | 12 V | 60/55 W | P43t |
| 61539 |  HB3 | 12 V | 60 W | P20d |



Cavi elettrici e guaine

Electric cables and sleeves

I prodotti recanti il marchio AMA qui indicati sono realizzati da AMA S.p.A. e destinati a essere utilizzati come ricambi adattabili e non originali. I riferimenti a marchi, codici originali e costruttori di terzi, riportati in corrispondenza degli articoli AMA compatibili, hanno esclusivamente la finalità di identificare il modello, l'applicazione o la destinazione d'uso del prodotto, in conformità a quanto previsto dal Regolamento (CE) n. 1400/2002 e dalla normativa vigente in materia di concorrenza e uso lecito dei marchi di terzi. / The products bearing the AMA brand name listed here are manufactured by AMA S.p.A. and are intended for use as adaptable, non-original spare parts. References to trademarks, original codes and third-party manufacturers, shown alongside compatible AMA items, are intended solely to identify the model, application or intended use of the product, in accordance with Regulation (EC) No. 1400/2002 and current legislation on competition and the lawful use of third-party trademarks.

CAVO ELETTRICO MULTIPOLARE H05VV-F

MULTICORE ELECTRICAL CABLE H05VV-F
 CÂBLE ÉLECTRIQUE MULTICONDUCTEUR H05VV-F
 MEHRADRIGES ELEKTROKABEL H05VV-F
 CABLE ELÉCTRICO MULTIPOLAR H05VV-F



| Skü | Modello / Model | Sezione / Section | Tensione nominale / Rated voltage | Temperatura di esercizio / Operating temperature | Diametro cavo / Cable diameter | Colore / Colour | Materiali / Material | Contenuto / Content |
|-------|-----------------|-------------------|-----------------------------------|--|--------------------------------|---|---|----------------------------|
| 19160 | H05VV-F | 2x1,00 | 300/500 V | Max 60° C | 6,60 mm | Guaina nera, fili: blu e marrone / Black sheath, conductors: blue and brown | Isolante: mescola PVC, guaina esterna: mescola PVC / Insulation: PVC compound, outer sheath: PVC compound | Matassa 100 m / 100 m coil |
| 19644 | H05VV-F | 2x1,50 | 300/500 V | Max 60° C | 7,50 mm | Guaina nera, fili: blu e marrone / Black sheath, conductors: blue and brown | Isolante: mescola PVC, guaina esterna: mescola PVC / Insulation: PVC compound, outer sheath: PVC compound | Matassa 100 m / 100 m coil |
| 19645 | H05VV-F | 2x2,50 | 300/500 V | Max 60° C | 9,30 mm | Guaina nera, fili: blu e marrone / Black sheath, conductors: blue and brown | Isolante: mescola PVC, guaina esterna: mescola PVC / Insulation: PVC compound, outer sheath: PVC compound | Matassa 100 m / 100 m coil |
| 19648 | H05VV-F | 3x1,50 | 300/500 V | Max 60° C | 8,10 mm | Guaina nera, fili: nero, blu e marrone / Black sheath, conductors: black, blue and brown | Isolante: mescola PVC, guaina esterna: mescola PVC / Insulation: PVC compound, outer sheath: PVC compound | Matassa 100 m / 100 m coil |
| 19651 | H005V-F | 4x1,00 | 300/500 V | Max 60° C | 8 mm | Guaina nera, fili: grigio, marrone, nero, giallo/verde / Black sheath, wires: grey, brown, black, yellow/green | Isolante: mescola PVC, guaina esterna: mescola PVC / Insulation: PVC compound, outer sheath: PVC compound | Matassa 100 m / 100 m coil |
| 19652 | H05VV-F | 4x1,50 | 300/500 V | Max 60° C | 7,80 mm | Guaina nera, fili: nero, rosso, blu e bianco / Black sheath, conductors: black, red, blue and white | Isolante: mescola PVC, guaina esterna: mescola PVC / Insulation: PVC compound, outer sheath: PVC compound | Matassa 100 m / 100 m coil |
| 19655 | H05VV-F | 5x1,50 | 300/500 V | Max 60° C | 10,10 mm | Guaina: Nero, Fili: Nero - Blu - Marrone - Giallo - Rosso / Jacket: Black, Cores: Black, Blue, Brown, Yellow, Red | Isolante: Mescola PVC, Guaina esterna: Mescola PVC | Matassa 100 m / 100 m coil |
| 02957 | H05VV-F | 5x1,00 | 300/500 V | Max 60° C | 8,50 mm | Guaina: Nero, Fili: Nero - Blu - Marrone - Giallo - Rosso / Black sheath, conductors: black, blue, brown, yellow and red | Isolante: mescola PVC, guaina esterna: mescola PVC / Insulation: PVC compound, outer sheath: PVC compound | Matassa 100 m / 100 m coil |
| 02958 | FROR | 7x1 | 300/500 V | -15°C; +70° C | 8,50 mm | Guaina nera, fili: nero, blu, rosso, verde, giallo, bianco e marrone / Black sheath, conductors: black, blue, red, green, yellow, white and brown | Isolante: mescola PVC, guaina esterna: mescola PVC / Insulation: PVC compound, outer sheath: PVC compound | Matassa 100 m / 100 m coil |
| 19659 | FROR | 7x1,5 / 7x1,6 | 450/750V | -15°C; +70° C | 8,50 mm | Guaina nera, fili: nero, blu, rosso, verde, giallo e bianco / Black sheath, conductors: black, blue, red, green, yellow and white | Isolante: mescola PVC, guaina esterna: mescola PVC / Insulation: PVC compound, outer sheath: PVC compound | Matassa 100 m / 100 m coil |

CAVO UNIPOLARE F3

 UNIPOLAR CABLE F3
 CÂBLE UNIPOLAIRE ÉLECTRIQUE F3
 UNIPOLARES KABEL F3
 CABLE UNIPOLAR ELÉCTRICO F3

| Skü | Modello / Model | Sezione / Section | Tensione di esercizio / Operating voltage | Intensità di corrente / Current intensity | Diametro cavo / Cable diameter | Temperatura di esercizio / Operating temperature | Colore / Colour | Contenuto / Content |
|-------|-----------------|-------------------|---|---|--------------------------------|--|--|--|
| 85565 | F3 105° | 1x1,00 | 300 V | 11,0 A | 2,10 mm | -40° / +105° C | Guaina: Nero, Fili: Nero / Sheath: Black, Wires: Black | Matassa in box 100 m / 100 m coil in box |
| 85567 | F3 105° | 1x1,00 | 300 V | 11,0 A | 2,10 mm | -40° / +105° C | Guaina: Grigio, Fili: Grigio / Sheath: Grey, Wires: Grey | Matassa in box 100 m / 100 m coil in box |
| 85568 | F3 105° | 1x1,00 | 300 V | 11,0 A | 2,10 mm | -40° / +105° C | Guaina: Verde, Fili: Verde / Sheath: Green, Wires: Green | Matassa in box 100 m / 100 m coil in box |
| 85572 | F3 105° | 1x1,50 | 300 V | 14,0 A | 2,40 mm | -40° / +105° C | Guaina: Nero, Fili: Nero / Sheath: Black, Wires: Black | Matassa in box 100 m / 100 m coil in box |
| 85573 | F3 105° | 1x1,50 | 300 V | 14,0 A | 2,40 mm | -40° / +105° C | Guaina: Grigio, Fili: Grigio / Sheath: Grey, Wires: Grey | Matassa in box 100 m / 100 m coil in box |
| 85574 | F3 105° | 1x1,50 | 300 V | 14,0 A | 2,40 mm | -40° / +105° C | Guaina: Verde, Fili: Verde / Sheath: Green, Wires: Green | Matassa in box 100 m / 100 m coil in box |
| 85575 | F3 105° | 1x1,50 | 300 V | 14,0 A | 2,40 mm | -40° / +105° C | Guaina: Rosso, Fili: Rosso / Sheath: Red, Wires: Red | Matassa in box 100 m / 100 m coil in box |
| 85576 | F3 105° | 1x2,50 | 300 V | 20,0 A | 3 mm | -40° / +105° C | Guaina: Nero, Fili: Nero / Sheath: Black, Wires: Black | Matassa in box 100 m / 100 m coil in box |
| 85577 | F3 105° | 1x2,50 | 300 V | 20,0 A | 3 mm | -40° / +105° C | Guaina: Rosso, Fili: Rosso / Sheath: Red, Wires: Red | Matassa in box 100 m / 100 m coil in box |
| 85578 | F3 105° | 1x2,50 | 300 V | 20,0 A | 3 mm | -40° / +105° C | Guaina: Marrone, Fili: Marrone / Sheath: Brown, Wires: Brown | Matassa in box 100 m / 100 m coil in box |
| 85579 | F3 105° | 1x4,00 | 300 V | 28,0 A | 3,70 mm | -40° / +105° C | Guaina: Nero, Fili: Nero / Sheath: Black, Wires: Black | Matassa in box 100 m / 100 m coil in box |
| 85580 | F3 105° | 1x4,00 | 300 V | 28,0 A | 3,70 mm | -40° / +105° C | Guaina: Rosso, Fili: Rosso / Sheath: Red, Wires: Red | Matassa in box 100 m / 100 m coil in box |
| 85583 | F3 105° | 1x6,00 | 300 V | 37,0 A | 4,30 mm | -40° / +105° C | Guaina: Rosso, Fili: Rosso / Sheath: Red, Wires: Red | Matassa in box 100 m / 100 m coil in box |

NASTRO ISOLANTE

 NASTRO ISOLANTE
 INSULATING TAPES
 BANDE ISOLANTE
 ISOLIERBÄNDER

| Skü | Colore / Colour | Lunghezza / Length | Larghezza / Width | Note / Notes |
|-------|-----------------|--------------------|-------------------|--|
| 59009 | Nero | 10 m | 1,50 cm | NOTE: - Conforme alle normative IEC 60454-3-1 (VDE, IMQ, SEMKO), certificato VOC, RoHS 2.0 e REACH - Resistente al calore fino a +90° C - Elevato potere isolante / NOTE: - Compliant with IEC 60454-3-1 standards (VDE, IMQ, SEMKO), VOC certified, RoHS 2.0 and REACH - Heat resistant up to +90°C - High insulating power |

TUBO CORRUGATO DI PROTEZIONE CHIUSO

CLOSED PROTECTIVE CORRUGATED TUBE
TUBE DE PROTECTION ONDULÉ FERMÉ
SCHUTZSCHLAUCH GEWELLT, GESCHLOSSEN
TUBO CORRUGADO DE PROTECCIÓN CERRADO



| Skü | Sezione / Section | Diametro esterno / Outer diameter | Diametro interno / Inlet diameter | Confezionamento / Packaging |
|-------|-------------------|-----------------------------------|-----------------------------------|-----------------------------|
| 12594 | NW 4,5mm | 7,1 mm | 5 mm | 100 m |
| 12595 | NW 7,5 mm | 9,9 mm | 6,9 mm | 100 m |
| 12596 | NW 8,5mm | 11,6 mm | 8,5 mm | 50 m |
| 12597 | NW 10,00mm | 12,7 mm | 10,1 mm | 50 m |
| 12598 | NW 13,00mm | 15,8 mm | 12,9 mm | 50 m |
| 12599 | NW 17,00mm | 21 mm | 16,8 mm | 50 m |
| 12600 | NW 22,00mm | 25,5 mm | 21,8 mm | 50 m |

TUBO CORRUGATO DI PROTEZIONE APERTO

OPEN PROTECTIVE CORRUGATED TUBE
TUBE DE PROTECTION ONDULÉ OUVERTE
SCHUTZSCHLAUCH GEWELLT, OFFEN
TUBO CORRUGADO DE PROTECCIÓN ABIERTO



| Skü | Diametro esterno / Outer diameter | Diametro interno / Inlet diameter | Confezionamento / Packaging |
|-------|-----------------------------------|-----------------------------------|-----------------------------|
| 63071 | 7,1 mm | 4,5 mm | 100 m |
| 63072 | 9,9 mm | 7,5 mm | 50 m |
| 63073 | 11,5 mm | 8,5 mm | 50 m |
| 63074 | 12,7 mm | 10 mm | 50 m |
| 63075 | 15,8 mm | 13 mm | 50 m |
| 63076 | 21 mm | 17 mm | 50 m |
| 63077 | 25,5 mm | 22 mm | 50 m |

GUAINA TERMORETRAIBILE CON ADESIVO

ADHESIVE LINED HEAT SHRINK TUBE
GUAINA THERMORETRACTABLE AVEC ADHESIF
SCHRUMPFSCHAUCH KLEBER
MANGUERA ENCOGIBLE CON ADHESIVO



| Skü | Sezione / Section | Tipo / Type | Colore / Colour | Temperatura di esercizio / Operating temperature | Contenuto / Content |
|-------|--|-------------|-----------------|--|---------------------|
| 64463 | Rapporto di restringimento 3:1 / Shrink ratio: 3:1 | 19/6 mm | Nero / Black | -55° / 110° C, temperatura di restringimento 95° C / -55° to +110° C, shrink temperature 95° C | 2 m |



Accessori cablaggio elettrico

Electrical wiring accessories

I prodotti recanti il marchio AMA qui indicati sono realizzati da AMA S.p.A. e destinati a essere utilizzati come ricambi adattabili e non originali. I riferimenti a marchi, codici originali e costruttori di terzi, riportati in corrispondenza degli articoli AMA compatibili, hanno esclusivamente la finalità di identificare il modello, l'applicazione o la destinazione d'uso del prodotto, in conformità a quanto previsto dal Regolamento (CE) n. 1400/2002 e dalla normativa vigente in materia di concorrenza e uso lecito dei marchi di terzi. / The products bearing the AMA brand name listed here are manufactured by AMA S.p.A. and are intended for use as adaptable, non-original spare parts. References to trademarks, original codes and third-party manufacturers, shown alongside compatible AMA items, are intended solely to identify the model, application or intended use of the product, in accordance with Regulation (EC) No. 1400/2002 and current legislation on competition and the lawful use of third-party trademarks.

FUSIBILI LAMELLARI

BLADE FUSES
FUSIBLES À LAME
FLACHSICHERUNGEN
FUSIBLES DE CUCHILLA



| Skü | Colore / Colour | Intensità di corrente / Current intensity | Contenuto / Content |
|---------------|---------------------|---|---------------------|
| F17181 | Nero / Black | 1 A | 100 pz / 100 pcs |
| F17089 | Grigio / Grey | 2 A | 100 pz / 100 pcs |
| F17002 | Viola / Purple | 3 A | 100 pz / 100 pcs |
| F17003 | Rosa / Pink | 4 A | 100 pz / 100 pcs |
| F17004 | Beige / Light brown | 5 A | 100 pz / 100 pcs |
| 03879 | Marrone / Brown | 7,5 A | 100 pz / 100 pcs |
| 03875 | Rosso / Red | 10 A | 100 pz / 100 pcs |
| 03875C | Rosso | 10 A | 10 pezzi / 10 pcs |
| 03876 | Blu / Blue | 15 A | 100 pz / 100 pcs |
| 03876C | Blu | 15 A | 10 pezzi / 10 pcs |
| 03884 | Giallo / Yellow | 20 A | 100 pz / 100 pcs |
| 03880 | Bianco / White | 25 A | 100 pz / 100 pcs |
| 03885 | Verde / Green | 30 A | 100 pz / 100 pcs |
| F17074 | Arancione / Orange | 40 A | 100 pz / 100 pcs |

ASSORTIMENTO FUSIBILI LAMELLARI

BLADE FUSE ASSORTMENT
ASSORTIMENT DE FUSIBLES À LAME
SORTIMENT FLACHSICHERUNGEN
SURTIDO DE FUSIBLES DE CUCHILLA



| Skü | Modello / Model | Contenuto / Content |
|----------------|--|---------------------|
| 75748 | 3A 1 pz; 5A 1 pz; 7,5A 1 pz; 10A 2 pz; 15A 1 pz; 20A 2 pz; 25A 1 pz; 30A 1 pz | 10 pezzi |
| 1001828 | 5A 1 pz, 7,5A 1 pz, 10A 2 pz, 15A 2 pz, 20A 2 pz, 25A 1 pz, 30A 1 pz | 10 pezzi |
| 85428 | 3A 12 pz, 5A 12 pz, 7,5A 12 pz, 10A 12 pz, 15A 12 pz, 20A 12 pz, 25A 12 pz, 30A 12 pz, estrattore 1 pz | 96 pezzi |

FUSIBILI LAMELLARI MINI

MINI BLADE FUSES
 FUSIBLES MINI À LAME
 MINI-FLACHSICHERUNGEN
 FUSIBLES DE CUCHILLA MINI



| Skü | Colore / Colour | Intensità di corrente / Current intensity | Contenuto / Content |
|---------------|---------------------|---|---------------------|
| F17170 | Viola / Purple | 3 A | 100 pz / 100 pcs |
| 58599 | Beige / Light brown | 5 A | 100 pz / 100 pcs |
| 58600 | Marrone / Brown | 7,5 A | 100 pz / 100 pcs |
| 58601 | Rosso / Red | 10 A | 100 pz / 100 pcs |
| 58602 | Blu / Blue | 15 A | 100 pz / 100 pcs |
| 58603 | Giallo / Yellow | 20 A | 100 pz / 100 pcs |
| 58604 | Naturale / Natural | 25 A | 100 pz / 100 pcs |
| 58605 | Verde / Green | 30 A | 100 pz / 100 pcs |

ASSORTIMENTO FUSIBILI LAMELLARI MINI

MINI BLADE FUSE ASSORTMENT
 ASSORTIMENT DE FUSIBLES À LAME MINI
 MINI-FLACHSICHERUNGS-SORTIMENT
 SURTIDO DE FUSIBLES DE CUCHILLA MINI



| Skü | Modello / Model | Contenuto / Content |
|----------------|--|---------------------|
| 1001827 | 5A 1 pz, 7,5A 1 pz, 10A 2 pz, 15A 2 pz, 20A 2 pz, 25A 1 pz, 30A 1 pz | 10 pezzi / 10 pcs |

FUSIBILI LAMELLARI MAXI

MAXI BLADE FUSES
FUSIBLES MAXI À LAME
MAXI-FLACHSICHERUNGEN
FUSIBLES DE CUCHILLA MAXI



| Skü | Colore / Colour | Intensità di corrente / Current intensity | Contenuto / Content |
|-------|------------------|---|---------------------|
| 59809 | Giallo / Yellow | 20 A | 20 pz / 20 pcs |
| 59810 | Verde / Green | 30 A | 20 pz / 20 pcs |
| 59811 | Arancio / Orange | 40 A | 20 pz / 20 pcs |
| 59812 | Rosso / Red | 50 A | 20 pz / 20 pcs |
| 59813 | Blu / Blue | 60 A | 20 pz / 20 pcs |
| 59814 | Marrone / Brown | 70 A | 20 pz / 20 pcs |
| 59815 | Bianco / White | 80 A | 20 pz / 20 pcs |
| 59816 | Viola / Purple | 100 A | 20 pz / 20 pcs |

FUSIBILI A SILURO

CONTINENTAL FUSES
FUSIBLES CONTINENTAL
SICHERUNGEN CONTINENTAL
FUSIBLES CONTINENTAL



| Skü | Colore / Colour | Intensità di corrente / Current intensity | Contenuto / Content |
|-------|-----------------|---|---------------------|
| 11910 | Giallo / Yellow | 5 A | 300 pz / 300 pcs |
| 02358 | Nero / Black | 8 A | 300 pz / 300 pcs |
| 11911 | Bianco / White | 10 A | 300 pz / 300 pcs |
| 01381 | Verde / Green | 16 A | 300 pz / 300 pcs |
| 02397 | Marrone / Brown | 25 A | 300 pz / 300 pcs |
| 01694 | Rosso / Red | 40 A | 300 pz / 300 pcs |

ASSORTIMENTO FUSIBILI A SILURO

CONTINENTAL FUSE ASSORTMENT
ASSORTIMENT DE FUSIBLES CONTINENTAL
SORTIMENT CONTINENTAL-SICHERUNGEN
SURTIDO DE FUSIBLES CONTINENTAL



| Skü | Contenuto / Content | Modello / Model |
|-------|--|--|
| 85429 | 75 fusibili a siluro, 3 portafusibili / 75 continental fuse, 3 fuse holder | 2A 10 pz, 5A 15 pz, 8A 20 pz, 16A 15 pz, 25A 15 pz, Portafusibile 1 pz |

ASSORTIMENTO FUSIBILI A SILURO E LAMELLARI

BLADE AND CONTINENTAL FUSE ASSORTMENT
 ASSORTIMENT DE FUSIBLES À LAME ET CONTINENTAL
 SORTIMENT CONTINENTAL- UND FLACHSICHERUNGEN
 SURTIDO DE FUSIBLES CONTINENTAL Y DE CUCHILLA



| Skü | Linea / Line | Contenuto / Content | Modello / Model |
|--------------|----------------------------|---------------------|--|
| 00263 | Fusibili a siluro e bilama | 600 pz | Fusibili a siluro: 8A 150 pz, 16A 150 pz, 40A 100 pz. Fusibili bilama: 7,5A 50 pz, 10A 50 pz, 15A 50 pz, 25A 50 pz |

FUSIBILI A NASTRO

STRIP FUSES
 FUSIBLES À RUBAN
 STREIFENSICHERUNG
 FUSIBLES A CINTA



| Skü | Tipo / Type | Contenuto / Content |
|---------------|-------------|---------------------|
| F17018 | 30A | 50 pz / 50 pcs |
| F17019 | 40A | 50 pz / 50 pcs |
| F17020 | 50A | 50 pz / 50 pcs |
| F17021 | 60A | 50 pz / 50 pcs |
| F17022 | 80A | 50 pz / 50 pcs |
| F17023 | 100A | 50 pz / 50 pcs |

FUSIBILI MEGA

MEGA FUSES
 FUSIBLES MEGA
 MEGA-SICHERUNGEN
 FUSIBLES MEGA



| Skü | Intensità di corrente / Current intensity | Contenuto / Content |
|---------------|---|---------------------|
| F17105 | 100 A | 5 pz / 5 pcs |
| F17106 | 125 A | 5 pz / 5 pcs |
| F17107 | 150 A | 5 pz / 5 pcs |
| F17109 | 175 A | 5 pz / 5 pcs |
| F17110 | 200 A | 5 pz / 5 pcs |
| F17112 | 250 A | 5 pz / 5 pcs |
| F17153 | 300 A | 3 pz / 3 pcs |

FUSIBILI MIDSCREW

MIDSCREW FUSES
MIDSCREW FUSIBLES
MIDSCREW SICHERUNGEN
MIDSCREW FUSIBLES



| Skü | Colore / Colour | Intensità di corrente / Current intensity | Contenuto / Content |
|-------|--------------------|---|---------------------|
| 55477 | arancione / orange | 30 A | 10 pz / 10 pcs |
| 55478 | verde / green | 40 A | 10 pz / 10 pcs |
| 55479 | rosso / red | 50 A | 10 pz / 10 pcs |
| 55480 | giallo / yellow | 60 A | 10 pz / 10 pcs |
| 55481 | marrone / brown | 70 A | 10 pz / 10 pcs |
| 55482 | bianco / white | 80 A | 10 pz / 10 pcs |
| 55483 | blu / blue | 100 A | 10 pz / 10 pcs |
| 55484 | rosa / pink | 125 A | 10 pz / 10 pcs |
| 55485 | grigio / grey | 150 A | 10 pz / 10 pcs |
| 55486 | viola / purple | 200 A | 10 pz / 10 pcs |

PORTAFUSIBILI PER FUSIBILI LAMELLARI

FUSE HOLDER BOX FOR BLADE FUSES
BOÎTE PORTE-FUSIBLES POUR FUSIBLES À LAME
SICHERUNGSHALTERBOX FÜR FLACHSICHERUNGEN
CAJA PORTAFUSIBLES PARA FUSIBLES DE CUCHILLA

| Skü | Numero poli / Number of poles | Note / Notes | Contenuto / Content |
|--------|-------------------------------|---|---------------------|
| 11912 | 1 | Fusibili e terminali non inclusi / Fuses and terminals not included | 20 pz / 20 pcs |
| 02842 | 1 | Fusibile 7,5A incluso / 7.5 A fuse included | 10 pz / 10 pcs |
| 03881 | 6 | Fusibili non inclusi / Fuses not included | 2 pz / 2 pcs |
| 55448 | 6 | Cobo, fusibili non inclusi / Blade fuses not included | 2 pz / 2 pcs |
| 03883 | 8 | Fusibili non inclusi / Fuses not included | 2 pz / 2 pcs |
| 03882 | 12 | Fusibili non inclusi / Fuses not included | 1 pz / 1 pcs |
| F17047 | 8 | Fusibili non inclusi / Fuses not included | 2 pz / 2 pcs |

PORTAFUSIBILI TENUTA STAGNA PER FUSIBILI MINI E LAMELLARI

WATERPROOF FUSE HOLDER FOR MINI AND BLADE FUSES
 PORTE-FUSIBLE ÉTANCHE POUR FUSIBLES MINI ET À LAME
 WASSERDICHTER SICHERUNGSHALTER FÜR MINI- UND FLACHSICHERUNGEN
 PORTAFUSIBLES IMPERMEABLE PARA FUSIBLES MINI Y DE CUCHILLA



| Skü | Numero poli / Number of poles | Modello / Model | Note / Notes | Contenuto / Content |
|--------------|-------------------------------|--|--|---------------------|
| 58608 | 1 | per fusibile lamellare mini / For mini blade fuses | Fusibile non incluso / Fuse not included | 10 pz / 10 pcs |
| 58609 | 1 | Per fusibile bilama / For blade fuses | Fusibile non incluso / Fuse not included | 10 pz / 10 pcs |

PORTAFUSIBILE PER FUSIBILI LAMELLARI MAXI CON ATTACCO A FASTON

FUSE HOLDER FOR MAXI BLADE FUSES WITH FASTON CONNECTION
 PORTE-FUSIBLE POUR FUSIBLES À LAME MAXI AVEC CONNEXION FASTON
 SICHERUNGSHALTER FÜR MAXI-FLACHSICHERUNGEN MIT FASTON-ANSCHLUSS
 PORTAFUSIBLE PARA FUSIBLES DE CUCHILLA MAXI CON CONEXIÓN FASTON



| Skü | Numero poli / Number of poles | Modello / Model | Note / Notes | Contenuto / Content |
|---------------|-------------------------------|---|---|---------------------|
| F17187 | 1 | Per fusibile lamellare Maxi / For Maxi blade fuse | Terminali inclusi, fusibile non incluso / Terminals included, fuse not included | 4 pz / 4 pcs |

PORTAFUSIBILE MAXI COMPONENTE



MODULAR MAXI FUSE HOLDER
 PORTE-FUSIBLE MAXI MODULABLE
 MODULARER MAXI-SICHERUNGSHALTER
 PORTAFUSIBLES MAXI COMPONENTE



| Skü | Numero poli / Number of poles | Modello / Model | Note / Notes | Contenuto / Content |
|---------------|-------------------------------|---|--|---------------------|
| F17133 | 1 | per fusibili lamellari Maxi / For maxi blade fuse | Fusibile non incluso / Fuse not included | 5 pz / 5 pcs |

PORTAFUSIBILI PER FUSIBILI A SILURO

CONTINENTAL FUSE HOLDER BOX
 BOÎTE PORTE-FUSIBLES POUR FUSIBLES CONTINENTAL
 CONTINENTAL-SICHERUNGSHALTERBOX
 CAJA PORTAFUSIBLES PARA FUSIBLES CONTINENTAL

| Skü | Numero poli / Number of poles | Note / Notes | Contenuto / Content |
|---|-------------------------------|--|---------------------|
|  <p>01372</p> | 1 | Fusibile 8 A incluso / 8 A fuse included | 20 pz / 20 pcs |
|  <p>15563</p> | 6 | Fusibili inclusi / Fuses included | 1 pz / 1 pcs |

PORTAFUSIBILE PER FUSIBILI A NASTRO

FUSE HOLDER FOR STRIP FUSES
 PORTE-FUSIBLE POUR FUSIBLES À RUBAN
 SICHERUNGSHALTER FÜR STREIFENSICHERUNG
 PORTAFUSIBILE PARA FUSIBLES DE CINTA



| Skü | Numero poli / Number of poles | Note / Notes | Contenuto / Content |
|---------------|-------------------------------|--|---------------------|
| F17025 | 1 | Fusibile non incluso / Fuse not included | 5 pz / 5 pcs |

PORTAFUSIBILE PER FUSIBILI MEGA

FUSE HOLDER FOR MEGA FUSE
 PORTE-FUSIBLE POUR FUSIBLE MEGA
 SICHERUNGSHALTER FÜR MEGA-SICHERUNG
 PORTAFUSIBILE PARA FUSIBLE MEGA



| Skü | Numero poli / Number of poles | Note / Notes | Contenuto / Content |
|---------------|-------------------------------|---|---------------------|
| F17113 | 1 | Fusibile tipo Mega, non incluso, da ordinare separatamente. / Fuse not included | 2 pz / 2 pcs |

PORTAFUSIBILI MIDSCREW

 MIDSCREW FUSE HOLDER
 MIDSCREW PORTE-FUSIBLE
 MIDSCREW SICHERUNGSHALTER
 MIDSCREW PORTAFUSIBLE

| Skù | Numero poli / Number of poles | Note / Notes | Contenuto / Content |
|-------|-------------------------------|--|---------------------|
| 55487 | 1 | Fusibile non incluso / Fuse not included | 3 pz / 3 pcs |



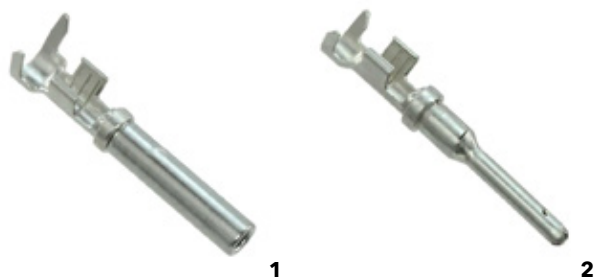

TERMINALI CONNEX









 CONNEXTERMINALS
 COSSES CONNEX
 CONNEX-KABELSCHUHE
 TERMINALES CONNEX

| Skù | Pos. | Modello / Model | Sezione / Section | Intensità di corrente / Current intensity | Linea / Line | Contenuto / Content |
|-------|------|--------------------------------|--------------------------------|---|--------------|---------------------|
| 57683 | 1 | connex maschio / male connex | AWG 2,0 - 0,75 mm ² | 15 A | 1062-16-0122 | 40 pz / 40 pcs |
| 57684 | 2 | connex femmina / female connex | AWG 2,0 - 0,75 mm ² | 15 A | 1060-16-0122 | 40 pz / 40 pcs |

TERMINALI

 TERMINALS
 COSSES
 KABELSCHUHE
 TERMINALES

| Skù | Modello / Model | Linea / Line | Sezione / Section | Materiali / Material | Contenuto / Content |
|--------|---|----------------------------------|----------------------------|----------------------|---------------------|
| 01880 |  terminale femmina / female terminal | serie 6,3 mm | 1,0 ÷ 2,5 mm ² | Ottone / Brass | 200 pz / 200 pcs |
| 01880C |  terminale femmina / female terminal | serie 6,3 mm | 1,0 ÷ 2,5 mm ² | Ottone / Brass | 10 pz / 10 pcs |
| 01881 |  terminale maschio / male terminal | serie 6,3 mm / 6.3 mm series | 1,0 ÷ 2,5 mm ² | Ottone / Brass | 200 pz / 200 pcs |
| 01882 |  terminale maschio / male terminal | cilindrico Ø 4 / cylindrical Ø 4 | 0,75 ÷ 2,0 mm ² | Ottone / Brass | 200 pz / 200 pcs |

| Skü | Modello / Model | Linea / Line | Sezione / Section | Materiali / Material | Contenuto / Content |
|--------|---|--|---------------------------|---------------------------------|---------------------|
| 01883 |  terminale femmina / female terminal | cilindrico Ø 4 / cylindrical Ø 4 | 1,0 ÷ 2,5 mm ² | Ottone / Brass | 200 pz / 200 pcs |
| 02582 |  terminale femmina con gancio / female terminal with latch | serie 6,3 mm per connessioni multiple / 6.3 mm series for multiple connections | 1,0 ÷ 2,5 mm ² | Ottone / Brass | 200 pz / 200 pcs |
| 02582C |  terminale femmina con gancio / female terminal with latch | serie 6,3 mm per connessioni multiple / 6.3 mm series for multiple connections | 1,0 ÷ 2,5 mm ² | Ottone / Brass | 10 pz / 10 pcs |
| 02583 |  terminale maschio con gancio / male terminal with latch | serie 6,3 mm per connessioni multiple / 6.3 mm series for multiple connections | 1,0 ÷ 2,5 mm ² | Ottone / Brass | 100 pz / 100 pcs |
| 02583C |  terminale maschio con gancio / male terminal with latch | serie 6,3 mm per connessioni multiple / 6.3 mm series for multiple connections | 1,0 ÷ 2,5 mm ² | Ottone / Brass | 10 pz / 10 pcs |
| 02588 |  terminale / terminal | ad occhio Ø 6 / eyelet Ø 6 | 3,0 ÷ 6,0 mm ² | Ottone / Brass | 100 pz / 100 pcs |
| 11914 |  terminale femmina / female terminal | serie 6,3 mm / 6.3 mm series | 1,0 ÷ 2,5 mm ² | Rame / Copper | 200 pz / 200 pcs |
| 64582 |  capocorda preisolato / pre-insulated terminal | ad occhio Ø 8 / eyelet Ø 8 | 35 mm ² | Rame elettrolitico / ETP Copper | 25 pz / 25 pcs |
| 64583 |  capocorda preisolato / pre-insulated terminal | ad occhio Ø 10 / eyelet Ø 10 | 35 mm ² | Rame elettrolitico / ETP Copper | 25 pz / 25 pcs |

TERMINALI ISOLATI TERMORETRAIBILI



HEAT SHRINK INSULATED TERMINALS
 COSSES ISOLÉES THERMORÉTRACTABLES
 WÄRMESCHRUMPF-ISOLIERTE KABELSCHUHE
 TERMINALES AISLADOS TERMORRETRACTILES



| Skü | Colore / Colour | Sezione / Section | Contenuto / Content |
|-------|-----------------|-----------------------------|---------------------|
| 58611 | Rosso / Red | 0,75 - 1,25 mm ² | 40 pz / 40 pcs |
| 58612 | Blu / Blue | 1,25 - 2,50 mm ² | 20 pz / 20 pcs |
| 58613 | Giallo / Yellow | 2,50 - 6,00 mm ² | 20 pz / 20 pcs |

TERMINALI MASCHIO E FEMMINA

MALE AND FEMALE TERMINALS
 TERMINAUX MÂLES ET FEMELLES
 MÄNNLICHE UND WEIBLICHE STECKVERBINDER
 TERMINALES MACHO Y HEMBRA

| Skü | Colore / Colour | Sezione / Section | Dimensioni / Dimensions | Contenuto / Content |
|---|-----------------|-----------------------|-------------------------|---------------------|
|  51759 | Rosso / Red | 0,25÷1mm ² | 6,3x0,8mm | 200 pz / 200 pcs |
|  51760 | Blu / Blue | 1÷2,5mm ² | 6,3x0,8mm | 200 pz / 200 pcs |

TERMINALI FEMMINA PREISOLATI

PRE-INSULATED FEMALE TERMINALS
 TERMINAUX FEMELLES PRÉISOLÉS
 VORGEISOLIERTER FLANSCHVERBINDER
 TERMINALES HEMBRA PREAISLADOS



| Skü | Colore / Colour | Sezione / Section | Dimensioni / Dimensions | Lunghezza / Length | Contenuto / Content |
|--------------|-----------------|-----------------------------|-------------------------|--------------------|---------------------|
| 51750 | Rosso / Red | 0,25÷1,65 mm ² | 6,4x0,8mm | 2,10 cm | 200 pz / 200 pcs |
| 51751 | Blu / Blue | 1,04 - 2,63 mm ² | 4,8x0,5mm | 1,90 cm | 200 pz / 200 pcs |
| 51752 | Blu / Blue | 1,04 - 2,63 mm ² | 6,4x0,8 mm | 2,10 cm | 200 pz / 200 pcs |
| 51753 | Giallo / Yellow | 2,63 - 6,64 mm ² | 6,4x0,8mm | 2,40 cm | 200 pz / 200 pcs |
| 51754 | Giallo / Yellow | 2,63 - 6,64 mm ² | 9,4x1 mm | 3,01 cm | 100 pz / 100 pcs |

TERMINALI FEMMINA COMPLETAMENTE ISOLATI

INSULATED FEMALE TERMINALS
 TERMINAUX FEMELLES ISOLÉS
 VOLLSTÄNDIG ISOLIERTE FLANSCHVERBINDER
 TERMINALES HEMBRA TOTALMENTE AISLADOS



| Skü | Colore / Colour | Sezione / Section | Dimensioni / Dimensions | Contenuto / Content |
|--------------|-----------------|---------------------------|-------------------------|---------------------|
| 51756 | Blu / Blue | 1,04÷2,63 mm ² | 6,4x0,8 mm | 200 pz / 200 pcs |
| 51755 | Rosso / Red | 0,25÷1,65 mm ² | 6,4x0,8 mm | 200 pz / 200 pcs |

TERMINALI MASCHIO 6,35X0,8 MM

MALE TERMINALS 6.35X0.8 MM
 TERMINAUX MÂLES 6,35X0,8 MM
 MÄNNLICHE STECKVERBINDER 6,35X0,8 MM
 TERMINALES MACHO 6,35X0,8 MM



| Skü | Colore / Colour | Sezione / Section | Dimensioni / Dimensions | Contenuto / Content |
|-------|-----------------|---------------------------|-------------------------|---------------------|
| 51757 | Rosso / Red | 0,25÷1,65 mm ² | 6,35x0,8 mm | 200 pz / 200 pcs |
| 51758 | Blu / Blue | 1,04÷2,63 mm ² | 6,35x0,8 mm | 200 pz / 200 pcs |

TERMINALI CILINDRICI

CYLINDRICAL TERMINALS
 COSSES CYLINDRIQUES
 ZYLINDRISCHE KABELSCHUHE
 TERMINALES CILÍNDRICOS



| Skü | Colore / Colour | Sezione / Section | Diametro / Diameter | Materiali / Material | Note / Notes | Contenuto / Content |
|-------|-----------------|--------------------------|---------------------|----------------------|--|---------------------|
| 51767 | Blu / Blue | 1,04÷2,63mm ² | 5 mm | PVC | Temperatura 75°C, 300V / 75°C Temperature, 300 V | 200 pz / 200 pcs |
| 51768 | Blu / Blue | 1,04÷2,63mm ² | 5 mm | PVC | Temperatura 75°C, 300V / 75°C Temperature, 300 V | 200 pz / 200 pcs |

TERMINALI AD OCCHIELLO A DOPPIA TENUTA

DOUBLE-SEALED RING TERMINALS
 COSSES À CEILLET À DOUBLE ÉTANCHÉITÉ
 RINGKABELSCHUHE MIT DOPPELTER ABDICHTUNG
 TERMINALES DE ANILLO CON DOBLE SELLADO



| Skü | Colore / Colour | Diametro / Diameter | Sezione / Section | Lunghezza / Length | Materiali / Material | Note / Notes | Contenuto / Content |
|-------|-----------------|---------------------|--------------------------|--------------------|----------------------|---|---------------------|
| 51761 | Blu / Blue | 3,7 mm | 1,04÷2,63mm ² | 2,06 cm | PVC | Temperatura 75°C, 600V / 75 °C Temperature, 600 V | 200 pz / 200 pcs |
| 51762 | Blu / Blue | 5,3 mm | 1,04÷2,63mm ² | 2,30 cm | PVC | Temperatura 75°C, 600V / 75 °C Temperature, 600 V | 200 pz / 200 pcs |
| 51763 | Blu / Blue | 6,4 mm | 1,04÷2,63mm ² | 2,81 cm | PVC | Temperatura 75°C, 600V / 75 °C Temperature, 600 V | 200 pz / 200 pcs |
| 51764 | Blu / Blue | 8,4 mm | 1,04÷2,63mm ² | 2,81 cm | PVC | Temperatura 75°C, 600V / 75 °C Temperature, 600 V | 100 pz / 100 pcs |
| 51765 | Giallo / Yellow | 8,4 mm | 2,63÷6,64mm ² | 3,49 cm | PVC | Temperatura 75°C, 600V / 75 °C Temperature, 600 V | 100 pz / 100 pcs |
| 75940 | Blu / Blue | 10 mm | 1,5÷2,5mm ² | 3,09 cm | PVC | Temperatura 75°C, 600V / 75 °C Temperature, 600 V | 200 pz / 200 pcs |
| 51766 | Giallo / Yellow | 10,5 mm | 2,63÷6,64mm ² | 1,05 cm | PVC | Temperatura 75°C, 600V / 75 °C Temperature, 600 V | 100 pz / 100 pcs |

CAPOCORDA TUBOLARE PER CONDUTTORI IN RAME

TUBULAR TERMINAL FOR COPPER CONDUCTORS
 BORNIER TUBULAIRE POUR CONDUCTEURS EN CUIVRE
 ROHRKLEMME FÜR KUPFERLEITER
 TERMINAL TUBULAR PARA CONDUCTORES DE COBRE



| Sku | Modello / Model | Sezione / Section | Diametro / Diameter | Lunghezza / Length | Materiali / Material | Contenuto / Content |
|-------|----------------------|--------------------|---------------------|--------------------|--------------------------------------|---------------------|
| 62486 | Vite M8 / M8 screw | 10 mm ² | 4,6 mm | 3,05 cm | Rame ETP stagnato/ Tinned ETP Copper | 25 pz / 25 pcs |
| 62487 | Vite M10 / M10 screw | 10 mm ² | 4,6 mm | 3,45 cm | Rame ETP stagnato/ Tinned ETP Copper | 25 pz / 25 pcs |
| 62488 | Vite M8 / M8 screw | 25 mm ² | 7 mm | 3,60 cm | Rame ETP stagnato/ Tinned ETP Copper | 25 pz / 25 pcs |
| 62489 | Vite M10 / M10 screw | 25 mm ² | 7 mm | 4 cm | Rame ETP stagnato/ Tinned ETP Copper | 25 pz / 25 pcs |
| 09182 | Vite M8 / M8 screw | 35 mm ² | 8,9 mm | 3,85 cm | Rame ETP stagnato/ Tinned ETP Copper | 25 pz / 25 pcs |
| 09183 | Vite M10 / M10 screw | 35 mm ² | 8,9 mm | 4,25 cm | Rame ETP stagnato/ Tinned ETP Copper | 25 pz / 25 pcs |
| 62492 | Vite M8 / M8 screw | 50 mm ² | 10 mm | 4,05 cm | Rame ETP stagnato/ Tinned ETP Copper | 10 pz / 10 pcs |
| 62493 | Vite M10 / M10 screw | 50 mm ² | 10 mm | 4,45 cm | Rame ETP stagnato/ Tinned ETP Copper | 10 pz / 10 pcs |
| 62494 | Vite M8 / M8 screw | 70 mm ² | 11,3 mm | 4,60 cm | Rame ETP stagnato/ Tinned ETP Copper | 10 pz / 10 pcs |
| 62495 | Vite M10 / M10 screw | 70 mm ² | 11,3 mm | 5 cm | Rame ETP stagnato/ Tinned ETP Copper | 10 pz / 10 pcs |

ASSORTIMENTO CAPICORDA

ASSORTMENT OF TERMINALS
 ASSORTIMENT DE COSSES
 SORTIMENT VON KABELSCHUHEN
 SURTIDO DE TERMINALES



| Sku | Brand / Brand | Contenuto / Content |
|-------|---------------|---------------------|
| 85427 | Ama | 157 pezzi / 157 pcs |

CAPOCORDA CON FISSAGGIO A PIASTRA

TERMINAL WITH PLATE FASTENING
 BORNIER AVEC FIXATION PAR PLAQUE
 KABELSCHUH MIT PLATTENBEFESTIGUNG
 TERMINAL CON FIJACIÓN A PLACA



| Sku | Sezione / Section | Diametro / Diameter | Materiali / Material | Contenuto / Content |
|-------|-------------------------|-----------------------------|--------------------------------|---------------------|
| 64481 | 25 ÷ 35 mm ² | foro 8,5 mm / 8,5 mm hole | Ottone stagnato / Tinned Brass | 10 pz / 10 pcs |
| 64482 | 25 ÷ 35 mm ² | foro 10,5 mm / 10,5 mm hole | Ottone stagnato / Tinned Brass | 10 pz / 10 pcs |
| 64483 | 50 ÷ 70 mm ² | foro 10,5 mm / 10,5 mm hole | Ottone stagnato / Tinned Brass | 10 pz / 10 pcs |
| 64484 | 50 ÷ 70 mm ² | foro 12,5 mm / 12,5 mm hole | Ottone stagnato / Tinned Brass | 10 pz / 10 pcs |

BLOCCHETTI CONNESSIONE

CONNECTOR HOUSINGS
CONNECTEURS
STECKVERBINDERGEHÄUSE
CONOCTORES



| Skü | Numero poli / Number of poles | Modello / Model | Terminali / Terminals | Prodotti compatibili / Compatible products | Contenuto / Content |
|-------|-------------------------------|--|----------------------------|--|---------------------|
| 12492 | 1 | Femmina (porta maschio) / Female terminal (accepts male) | Non inclusi / Not included | 02583 | 200 pz/ 200 pcs |
| 12493 | 1 | Maschio (porta femmina) / Male terminal (accepts female) | Non inclusi / Not included | 02582 | 200 pz/ 200 pcs |
| 12582 | 2 | Femmina (porta maschio) / Female terminal (accepts male) | Non inclusi / Not included | 02583 | 100 pz/ 100 pcs |
| 12583 | 2 | Maschio (porta femmina) / Male terminal (accepts female) | Non inclusi / Not included | 02582 | 100 pz/ 100 pcs |
| 12584 | 3 | Femmina (porta maschio) / Female terminal (accepts male) | Non inclusi / Not included | 02583 | 100 pz/ 100 pcs |
| 12585 | 3 | Maschio (porta femmina) / Male terminal (accepts female) | Non inclusi / Not included | 02582 | 100 pz/ 100 pcs |
| 12586 | 4 | Femmina (porta maschio) / Female terminal (accepts male) | Non inclusi / Not included | 02583 | 50 pz/ 50 pcs |
| 12587 | 4 | Maschio (porta femmina) / Male terminal (accepts female) | Non inclusi / Not included | 02582 | 50 pz/ 50 pcs |
| 12588 | 6 | Femmina (porta maschio) / Female terminal (accepts male) | Non inclusi / Not included | 02583 | 40 pz/ 40 pcs |
| 12589 | 6 | Maschio (porta femmina) / Male terminal (accepts female) | Non inclusi / Not included | 02582 | 50 pz/ 50 pcs |
| 12590 | 8 | Femmina (porta maschio) / Female terminal (accepts male) | Non inclusi / Not included | 02583 | 40 pz/ 40 pcs |
| 12591 | 8 | Maschio (porta femmina) / Male terminal (accepts female) | Non inclusi / Not included | 02582 | 40 pz/ 40 pcs |
| 12592 | 11 | Femmina (porta maschio) / Female terminal (accepts male) | Non inclusi / Not included | 02583 | 10 pz/ 10 pcs |
| 12593 | 11 | Maschio (porta femmina) / Male terminal (accepts female) | Non inclusi / Not included | 02582 | 10 pz/ 10 pcs |

BLOCCHETTO A 3 VIE PORTAFEMMINA

3-WAY TERMINAL BLOCK
BARRETTE À 3 VOIES
3-POLIGER KLEMMENBLOCK
BLOQUE DE TERMINALES DE 3 VÍAS



| Skü | Descrizione / Description | Contenuto / Content |
|-------|--|---------------------|
| 12491 | Blocchetto a 3 vie portafemmina per lampade proiettore H4 e R2 (asimmetriche) / 3 way connector for H4 & R2 bulb, 20,5x26,7x23 mm. | 10 pz/ 10 pcs |

CONNETTORI CONNEX



 PLUG HOUSING
 BOÎTIER DE CONNECTEUR
 STECKERGEHÄUSE
 CAJA PARA ENCHUFE

| Skü | Brand / Brand | Modello / Model | Numero poli / Number of poles | Terminali / Terminals | Note / Notes | Prodotti compatibili / Compatible products | Contenuto / Content |
|--------------|---|--|-------------------------------|----------------------------|--------------------------------------|--|---------------------|
| 57621 |  | Deutsch Maschio con piastrino / Male connector with wedge lock | 2 | Non inclusi / Not included | DT06-25+W2S Con piastra / With plate | 57683 | 5 pz / 5 pcs |
| 57622 |  | Deutsch Maschio con piastrino / Male connector with wedge lock | 3 | Non inclusi / Not included | DT06-35+W3S Con piastra / With plate | 57683 | 5 pz / 5 pcs |
| 57623 |  | Deutsch Maschio con piastrino / Male connector with wedge lock | 4 | Non inclusi / Not included | DT06-55+W4S Con piastra / With plate | 57683 | 4 pz / 4 pcs |
| 57624 |  | Deutsch Maschio con piastrino / Male connector with wedge lock | 6 | Non inclusi / Not included | DT06-65+W4S Con piastra / With plate | 57683 | 4 pz / 4 pcs |
| 57625 |  | Deutsch Maschio con piastrino / Male connector with wedge lock | 8 | Non inclusi / Not included | DT06-85+W8S Con piastra / With plate | 57683 | 4 pz / 4 pcs |
| 57627 |  | Deutsch Femmina con piastrino / Female connector with wedge lock | 2 | Non inclusi / Not included | DT04-2P+W2P Con piastra / With plate | 57684 | 5 pz / 5 pcs |
| 57628 |  | Deutsch Femmina con piastrino / Female connector with wedge lock | 3 | Non inclusi / Not included | DT04-3P+W3P Con piastra / With plate | 57684 | 5 pz / 5 pcs |
| 57629 |  | Deutsch Femmina con piastrino / Female connector with wedge lock | 4 | Non inclusi / Not included | DT04-4P+W4P Con piastra / With plate | 57684 | 4 pz / 4 pcs |
| 57630 |  | Deutsch Femmina con piastrino / Female connector with wedge lock | 6 | Non inclusi / Not included | DT04-6P+W6P Con piastra / With plate | 57684 | 4 pz / 4 pcs |
| 57631 |  | Deutsch Femmina con piastrino / Female connector with wedge lock | 8 | Non inclusi / Not included | DT04-8P+W8P Con piastra / With plate | 57684 | 4 pz / 4 pcs |

KIT CONNETTORE E CONTATTO

 SET OF CONNECTOR AND CONTACT PIN
 JEU DE CONNECTEUR ET CONTACT DE PIVOT
 SATZ STECKERGEHÄUSE MIT STIFTKONTAKT
 JUEGO DE CONECTOR Y TERMINAL DE CONTACTO

Gommini e terminali inclusi / Rubber pads and terminals included

| Skü | Brand / Brand | Sezione / Section | Numero poli / Number of poles | Contenuto / Content | |
|--------------|---|-------------------|-------------------------------|---------------------|----------------|
| 55471 |  | AMP | 1-1,5 mm ² | 1 | 10 pz / 10 pcs |
| 55571 |  | AMP | 1-1,5 mm ² | 1 | 10 pz / 10 pcs |
| 55472 |  | AMP | 1-1,5 mm ² | 2 | 10 pz / 10 pcs |

| Skü | Brand / Brand | Sezione / Section | Numero poli / Number of poles | Contenuto / Content |
|-------|---------------|-----------------------|-------------------------------|---------------------|
| 55572 | AMP | 1-1,5 mm ² | 2 | 10 pz / 10 pcs |
| 55473 | AMP | 1-1,5 mm ² | 3 | 10 pz / 10 pcs |
| 55573 | AMP | 1-1,5 mm ² | 3 | 10 pz / 10 pcs |
| 55474 | AMP | 1-1,5 mm ² | 4 | 10 pz / 10 pcs |
| 55574 | AMP | 1-1,5 mm ² | 4 | 10 pz / 10 pcs |
| 55475 | AMP | 1-1,5 mm ² | 5 | 5 pz / 5 pcs |
| 55575 | AMP | 1-1,5 mm ² | 5 | 5 pz / 5 pcs |
| 55476 | AMP | 1-1,5 mm ² | 6 | 5 pz / 5 pcs |
| 55576 | AMP | 1-1,5 mm ² | 6 | 5 pz / 5 pcs |

KIT ASSORTIMENTO CONNETTORI SUPERSEAL



SUPERSEAL CONNECTOR ASSORTMENT KIT
 KIT D'ASSORTIMENT DE CONNECTEURS SUPERSEAL
 SUPERSEAL-STECKVERBINDER-SORTIMENT
 KIT SURTIDO DE CONECTORES SUPERSEAL



| Skü | Contenuto / Content | Note / Notes |
|-------|--|--------------|
| 55470 | Connettore porta maschio 1 via 5 pz, Connettore porta femmina 1 via 5 pz, Connettore porta maschio 2 vie 10 pz, Connettore porta femmina 2 vie 10 pz, Connettore porta maschio 3 vie 5 pz, Connettore porta femmina 3 vie 5 pz, Connettore porta maschio 4 vie 5 pz, Connettore porta femmina 4 vie 5 pz, Connettore porta maschio 5 vie 5 pz, Connettore porta femmina 5 vie 5 pz, Connettore porta maschio 6 vie 4 pz, Connettore porta femmina 6 vie 4 pz. Terminale maschio sez. 1-1,5 200 pz, Terminale femmina sez. 2,6-3,3 200 pz. Gommino stagno rosso sez. 2,6-3,3 200 pz, Gommino stagno giallo sez. 1,8-2,4 200 pz / 5x Male connector 1 pin, 5x Female connector 1 pin, 10x Male connector 2 pin, 10x Female connector 2 pin, 5x Male connector 2 pin, 5x Female connector 2 pin, 5x Male connector 3 pin, 5x Female connector 3 pin, 5x Male connector 4 pin, 5x Female connector 4 pin, 4x Male connector 6 pin, 4x Female connector 6 pin, 200x Male terminal 1-1,5, 200x Female terminal 2,6-3,3, 200x Red wire seal, 200x Yellow wire seal. | 868 pcs |

GIUNTI DI DERIVAZIONE

QUICK SPLICE CONNECTORS
CONNECTEURS DE DÉRIVATION RAPIDES
SCHNELLABZWEIGVERBINDER
CONECTORES DE DERIVACIÓN RÁPIDA

| Skü | Colore / Colour | Sezione / Section | Dimensioni / Dimensions | Note / Notes | Contenuto / Content |
|--|-----------------|-----------------------------|-------------------------|---|---------------------|
| 11915  | Rosso / Red | 0,25 ÷ 1,65 mm ² | 20x27 mm | Temperatura 105°C, 600V / 105°C Temperature, 600V | 100 pz / 100 pcs |
| 11916  | Blu / Blue | 1,04 ÷ 2,63mm ² | 20x27 mm | Temperatura 105°C, 600V / 105°C Temperature, 600V | 50 pz / 50 pcs |

CONNETTORI BIPOLARI AD ALTA CORRENTE

HIGH CURRENT BIPOLAR PLUGS
FICHE BIPOLAIRES HAUTE INTENSITÉ
HOCHSTROM-BIPOLARSTECKER
ENCHUFE BIPOLARES DE ALTA CORRIENTE

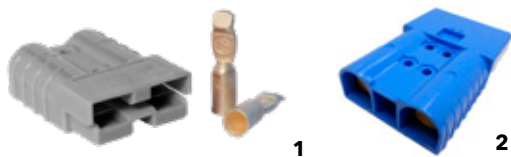

| Skü | Pos. | Tensione nominale / Rated voltage | Numero poli / Number of poles | Colore / Colour | Sezione / Section | Note / Notes | Contenuto / Content |
|---------------|------|-----------------------------------|-------------------------------|-----------------|------------------------------|--------------------------------------|---------------------|
| 17422 | 1 | 24 V | bipolare / bipolar | Rosso / Red | 13,5 mm ² (6 AWG) | Contatti inclusi / Contacts included | 4 pz / 4 pcs |
| 17421 | 1 | 36 V | bipolare / bipolar | Grigio / Grey | 13,5 mm ² (6 AWG) | Contatti inclusi / Contacts included | 4 pz / 4 pcs |
| P19038 | 2 | 48 V | bipolare / bipolar | Blu / Blue | 13,5 mm ² (6 AWG) | Contatti inclusi / Contacts included | 1 pz / 1 pcs |

CAPPUCCI PER TERMINALI





TERMINAL COVERS
CAPUCHONS POUR BORNES
KAPPEN FÜR KABELSCHUHE
TAPAS PARA TERMINALES



| Skü | Pos. | Modello / Model | Lunghezza / Length | Dimensioni / Dimensions | Prodotti compatibili / Compatible products | Contenuto / Content |
|--------------|------|------------------|--------------------|--|--|---------------------|
| 02146 | 1 | Maschio / Male | 22,50 mm | Fori: 10,5 mm, 6,4 mm / Holes: 10,5 mm, 6,4 mm | 01881 | 400 pz / 400 pcs |
| 02581 | 2 | Femmina / Female | 22,40 mm | Fori: 9 mm, 6 mm / Holes: 9 mm, 6 mm | 01880 | 400 pz / 400 pcs |



CAPPUCCI DI PROTEZIONE PER CAPOCORDA

PROTECTION CAPS FOR TERMINAL
 COUPELLES DE PROTECTION POUR COSSES DE CÂBLE
 SCHUTZKAPPEN FÜR KABELSCHUHE
 TAPAS DE PROTECCIÓN PARA TERMINALES

| SKU | Lunghezza / Length | Materiali / Material | A | B | Contenuto / Content |
|---|--------------------|----------------------|---------|------------|---------------------|
|  <p>19588</p> | 4,10 cm | PVC | 15 mm | 7,5 mm | 20 pz / 20 pcs |
|  <p>19589</p> | 5,65 cm | PVC | 19 mm | 16 mm | 20 pz / 20 pcs |
|  <p>62184</p> | 6 cm | PVC | 22,5 mm | 23 mm | 40 pz / 40 pcs |
|  <p>62198</p> | 4,10 cm | PVC | 30 mm | 41x17,7 mm | 10 pz / 10 pcs |

CAPPUCCI DI PROTEZIONE

PROTECTIVE CAPS
 CAPUCHONS DE PROTECTION
 SCHUTZKAPPEN
 CAPUCHONES DE PROTECCIÓN

| SKU | Descrizione / Description | Contenuto / Content |
|--|--|---------------------|
|  <p>M21129</p> | Cappuccio grande 55X18X70 mm in PVC, colore nero, per blocchetto 8 vie femmina art. 12590 / Large cap 55x18x70 mm in PVC, black color, for 8-way female block item 12590 | 20 pz / 20 pcs |
|  <p>M21130</p> | Cappuccio piccolo 45x18x55 mm in PVC colore nero per blocchetto 8 vie maschio art. 12591 / Small cap 45x18x55 mm in PVC, black color, for 8-way male block item 12591 | 20 pz / 20 pcs |



Avvisatori acustici

Audible warning devices

I prodotti recanti il marchio AMA qui indicati sono realizzati da AMA S.p.A. e destinati a essere utilizzati come ricambi adattabili e non originali. I riferimenti a marchi, codici originali e costruttori di terzi, riportati in corrispondenza degli articoli AMA compatibili, hanno esclusivamente la finalità di identificare il modello, l'applicazione o la destinazione d'uso del prodotto, in conformità a quanto previsto dal Regolamento (CE) n. 1400/2002 e dalla normativa vigente in materia di concorrenza e uso lecito dei marchi di terzi. / The products bearing the AMA brand name listed here are manufactured by AMA S.p.A. and are intended for use as adaptable, non-original spare parts. References to trademarks, original codes and third-party manufacturers, shown alongside compatible AMA items, are intended solely to identify the model, application or intended use of the product, in accordance with Regulation (EC) No. 1400/2002 and current legislation on competition and the lawful use of third-party trademarks.

AVVISATORI ACUSTICI ELETTROMAGNETICI A DISCO DIAMETRO 90 MM





ELECTROMAGNETIC DISC HORNS, 90 MM DIAMETER
 AVERTISSEURS SONORES ÉLECTROMAGNÉTIQUES À DISQUE, DIAMÈTRE 90 MM
 ELEKTROMAGNETISCHE SCHEIBENHUPEN, DURCHMESSER 90 MM
 AVISADORES ACÚSTICOS ELECTROMAGNÉTICOS DE DISCO, DIÁMETRO 90 MM



| Skü | Tensione nominale / Rated voltage | Emissioni sonore / Sound emissions | Frequenza / Frequency | Assorbimento di corrente / Current consumption | Grado protezione ip / Degree of protection ip | Materiali / Material | Certificazioni / Certifications | Specifiche / Specifications |
|--------------|-----------------------------------|------------------------------------|-----------------------|--|---|----------------------|---------------------------------|--|
| 00437 | 12 V | 113 dB | 430 Hz | <4A | IP65 | acciaio / steel | ECE-R10, ECE-R28 | n. 2 terminali faston 6,3 mm / No. 2 Faston terminals 6,3 mm |
| 04508 | 24 V | 113 dB | 430 Hz | <2A | IP65 | acciaio / steel | ECE-R10, ECE-R28 | n. 2 terminali faston 6,3 mm / No. 2 Faston terminals 6,3 mm |
| 04509 | 36/48 V | 113 dB | 430 Hz | <1,2A | IP65 | acciaio / steel | ECE-R10, ECE-R28 | n. 2 terminali faston 6,3 mm / No. 2 Faston terminals 6,3 mm |



AVVISATORI ACUSTICI ELETTROMAGNETICI A DISCO 105~118DB

ELECTROMAGNETIC DISC HORN 105-118 DB
 AVERTISSEUR ACOUSTIQUE ÉLECTROMAGNÉTIQUE À DISQUE 105-118 DB
 ELEKTROMAGNETISCHE SCHEIBENHUPE 105-118 DB
 AVISADOR ACÚSTICO ELECTROMAGNÉTICO DE DISCO 105-118 DB

| Skü | Tensione nominale / Rated voltage | Emissioni sonore / Sound emissions | Frequenza / Frequency | Assorbimento di corrente / Current consumption | Grado protezione ip / Degree of protection ip | Materiali / Material | Certificazioni / Certifications | Diametro / Diameter | Collegamento elettrico / Electrical connection | |
|--------------|---|------------------------------------|-----------------------|--|---|----------------------|---------------------------------|----------------------|--|---|
| 77434 |  | 12 V | 105~118 dB | 350 Hz | 3,5 A | IP66 | acciaio / steel | ECE-R28, CE | 70 mm | faston 6,3 mm / 6,3 mm faston |
| 77435 |  | 12 V | 105~118 dB | 420 Hz | 4,5 A | IP66 | acciaio / steel | ECE-R28, ECE-R10, CE | 92 mm | connettore Deutsch DT06-2S, art. 57621, 57683 non inclusi / Deutsch connector, pnt. 57621, 57683 not included |
| 77436 |  | 24 V | 105~118 dB | 420 Hz | 4,5 A | IP66 | acciaio / steel | ECE-R28, ECE-R10, CE | 92 mm | connettore Deutsch DT06-2S, art. 57621, 57683 non inclusi / Deutsch connector, pn. 57621, 57683 not included |
| 77437 |  | 12V | 105~118 dB | 420 Hz | 3A | IP66 | acciaio / steel | ECE-R10, ECE-R28 | 92 mm | faston 6,3 mm / 6,3 mm faston |
| 77438 |  | 24V | 105~118 dB | 420 Hz | 3A | IP66 | acciaio / steel | ECE-R10, ECE-R29 | 92 mm | faston 6,3 mm / 6,3 mm faston |

AVVISATORE ACUSTICO ELETTROMAGNETICO A CHIOCCIOLA

ELECTROMAGNETIC SNAIL HORN
 AVERTISSEUR SONORE ÉLECTROMAGNÉTIQUE À TROMPE EN COLIMAÇON
 ELEKTROMAGNETISCHE SCHNECKENHUPE
 AVISADOR ACÚSTICO ELECTROMAGNÉTICO TIPO CARACOL

| Skü | Tensione nominale / Rated voltage | Emissioni sonore / Sound emissions | Frequenza / Frequency | Assorbimento di corrente / Current consumption | Materiali / Material | Certificazioni / Certifications | Collegamento elettrico / Electrical connection |
|-------|--|------------------------------------|-----------------------|--|---------------------------|---------------------------------|--|
| 01354 |  12 V | 109 dB | 500 Hz | <5A | acciaio, ABS / steel, ABS | ECE-R10, ECE-R28 | faston 6,3 mm / 6,3 mm faston |
| 51354 |  12 V | 105~118 dB | 500 Hz | 4,5 A | acciaio, ABS / steel, ABS | ECE-R28, CE | faston 6,3 mm / 6,3 mm faston |

SEGNALATORE ACUSTICO DI EMERGENZA PNEUMATICO AZIONATO A MANO

MANUAL HAND-OPERATED PNEUMATIC EMERGENCY HORN
 AVERTISSEUR SONORE D'URGENCE PNEUMATIQUE ACTIONNÉ MANUELLEMENT
 PNEUMATISCHES NOTSIGNALHORN, MANUELL BETÄTIGT
 SEÑAL ACÚSTICA DE EMERGENCIA NEUMÁTICA ACCIONADA MANUALMENTE



| Skü | Tipo di suono / Sound type | Emissioni sonore / Sound emissions |
|-------|----------------------------|------------------------------------|
| 56728 | Tromba / Trumpet | 115 dB(A) a 2 m |

AVVISATORI RETROMARCIA

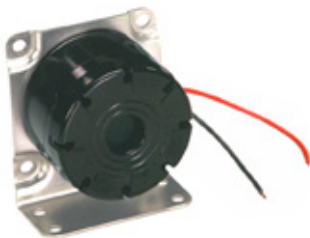

BACKUP ALARMS
 AVERTISSEURS DE RECUŁ
 RÜCKFAHRWARNER
 AVISADORES DE MARCHA ATRÁS



| Skü | Tensione nominale / Rated voltage | Emissioni sonore / Sound emissions | Tipo di suono / Sound type | Frequenza / Frequency | Assorbimento di corrente / Current consumption | Grado protezione ip / Degree of protection ip | Certificazioni / Certifications |
|-------|-----------------------------------|------------------------------------|------------------------------|-----------------------|--|---|---------------------------------|
| 09865 | 12V | 108 dB | Intermittente / Intermittent | 2800 Hz | 300mA | IP67 | CE |
| 09866 | 24V | 108 dB | Intermittente / Intermittent | 2800 Hz | 300mA | IP67 | RoHS |
| 19732 | 10-100V | ≥90 dB | Intermittente / Intermittent | 2800 Hz | 200mA | IP67 | CE, RoHS |

AVVISATORE ACUSTICO RETROMARCIA 10-100V

REVERSING ALARM 10-100V
 AVERTISSEUR DE REcul 10-100V
 RÜCKFAHRWARNER 10-100V
 AVISADOR ACÚSTICO DE MARCHA ATRÁS 10-100V

| Skü | Tensione nominale / Rated voltage | Emissioni sonore / Sound emissions | Tipo di suono / Sound type | Frequenza / Frequency | Assorbimento di corrente / Current consumption | Grado protezione ip / Degree of protection ip | Certificazioni / Certifications | Collegamento elettrico / Electrical connection |
|-------|---|------------------------------------|------------------------------|-----------------------|--|---|---------------------------------|---|
| 55357 |  10-100V | 92 dB | Intermittente / Intermittent | 1400 Hz | 300 mA | IP67 | CE, RoHS | cavi / cable |
| 65357 |  12-110V | 103~111 dB | Intermittente / Intermittent | 700~2800 Hz | 1,0 A | IP67 | ECE-R10, CE | connettore, art. 55572 non incluso / Connector, pn 55572 not included |

AVVISATORI RETROMARCIA

BACKUP ALARMS
 AVERTISSEURS DE REcul
 RÜCKFAHRWARNER
 AVISADORES DE MARCHA ATRÁS



| Skü | Tensione nominale / Rated voltage | Emissioni sonore / Sound emissions | Tipo di suono / Sound type | Frequenza / Frequency | Assorbimento di corrente / Current consumption | Diametro / Diameter | Grado protezione ip / Degree of protection ip | Certificazioni / Certifications |
|--------|-----------------------------------|------------------------------------|--|-----------------------|--|---------------------------------|---|---------------------------------|
| 27243 | 12-24 V | ≥ 90 dB | | 2900 ± 500 Hz | ≤ 20 mA/ | Foratura 28,5 mm / Hole 28,5 mm | IP54 | CE, RoHS |
| A27114 | 12-24 V | 90 dB | Continuo, Intermittente / Continuous, Intermittent | 2900 ± 500 Hz | 32 mA/ | Foratura 28,5 mm / Hole 28,5 mm | IP54 | Rohs |



Sistemi video

Video systems

I prodotti recanti il marchio AMA qui indicati sono realizzati da AMA S.p.A. e destinati a essere utilizzati come ricambi adattabili e non originali. I riferimenti a marchi, codici originali e costruttori di terzi, riportati in corrispondenza degli articoli AMA compatibili, hanno esclusivamente la finalità di identificare il modello, l'applicazione o la destinazione d'uso del prodotto, in conformità a quanto previsto dal Regolamento (CE) n. 1400/2002 e dalla normativa vigente in materia di concorrenza e uso lecito dei marchi di terzi. / The products bearing the AMA brand name listed here are manufactured by AMA S.p.A. and are intended for use as adaptable, non-original spare parts. References to trademarks, original codes and third-party manufacturers, shown alongside compatible AMA items, are intended solely to identify the model, application or intended use of the product, in accordance with Regulation (EC) No. 1400/2002 and current legislation on competition and the lawful use of third-party trademarks.

SISTEMI VIDEO 5" HD

5" HD VIDEO SYSTEM WITH MONITOR AND CAMERA
 SYSTÈME VIDÉO HD 5" AVEC MONITEUR ET CAMÉRA
 5"-HD-VIDEOSYSTEM MIT MONITOR UND KAMERA
 SISTEMA DE VÍDEO HD DE 5" CON MONITOR Y CÁMARA

**Articoli a ricambio**

| | | |
|--|----------------|--|
| | 0A27320 | Supporto di fissaggio che include due basi a sfera tonde e un braccio a doppia presa che consente una regolazione quasi infinita |
| | 55801 | Monitor 5,6" HD 4:3 per kit 55800 |
| | 55802 | Camera waterproof 12V per kit 55800, 55804, 55806 |
| | 84689 | Cavo a ricambio 20 m per 80819, 55800, 55804, 55806 |

| Skù | Tensione nominale / Rated voltage | Modello / Model | Monitor / Monitor | Risoluzione / Resolution | Camera / Camera | Temperatura di esercizio / Operating temperature | Certificazioni / Certifications |
|--------------|-----------------------------------|-----------------|--|--|--|--|---------------------------------|
| 55800 | Monitor: 12-24 V; Camera: 12V | 5,6" | Monitor a colori: Schermo 4:3; Luminosità: 250cd/M ² ; Contrasto: 300:1; Angolo: Dx/Sx: 60° Sup: 45°/Inf. 65°; Multilingua; Audio non disponibile | Monitor: 320(W)*480(H); Camera: N: 510*492 pixels P:500*582 pixels | Sensore: CMOS; TVL: 600; Lente: 2,5 mm | -20° C / 70° C | CE, RoHS, REACH, IP69K (camera) |

KIT VIDEOCAMERA 7" HD

 VIDEO CAMERA KIT 7" HD
 KIT CAMÉRA VIDÉO 7" HD
 7"-HD-VIDEOKAMERA-KIT
 7"-HD-VIDEOKAMERA-KIT

Articoli a ricambio

| | | |
|--|----------------|--|
| | 0A27320 | Supporto di fissaggio che include due basi a sfera tonde e un braccio a doppia presa che consente una regolazione quasi infinita |
| | 55802 | Camera waterproof 12V per kit 55800, 55804, 55806 |
| | 55805 | Monitor 7" HD 16:9 per kit 55804 55804 |
| | 84689 | Cavo a ricambio 20 m per 80819, 55800, 55804, 55806 |



| Skù | Tensione nominale / Rated voltage | Modello / Model | Monitor / Monitor | Risoluzione / Resolution | Camera / Camera | Temperatura di esercizio / Operating temperature |
|--------------|-----------------------------------|-----------------|---|---|---|--|
| 55804 | Monitor: 12-24 V; Camera: 12V | 7" | Monitor a colori: 7" HD; Schermo 16:9; Luminosità 450cd/M ² ; Contrasto: 500:1; Multilingua; Audio non disponibile | Monitor: 800*R.G.B.*480; Camera: PAL, NTSC 733(H)*493(V) | Sensore: CMOS; TVL: 700; Bilanciamento del bianco in automatico; FPS: PAL 50Hz / NTSC: 60Hz | -20°C; +70°C |

KIT VIDEOCAMERA 7" HD

 VIDEO CAMERA KIT 7" HD
 KIT CAMÉRA VIDÉO 7" HD
 7"-HD-VIDEOKAMERA-KIT
 7"-HD-VIDEOKAMERA-KIT

Articoli a ricambio

| | | |
|--|----------------|--|
| | 0A27320 | Supporto di fissaggio che include due basi a sfera tonde e un braccio a doppia presa che consente una regolazione quasi infinita |
| | 55802 | Camera waterproof 12V per kit 55800, 55804, 55806 |
| | 84689 | Cavo a ricambio 20 m per 80819, 55800, 55804, 55806 |



| Skù | Tensione nominale / Rated voltage | Modello / Model | Monitor / Monitor | Risoluzione / Resolution | Camera / Camera | Temperatura di esercizio / Operating temperature |
|--------------|-----------------------------------|-----------------|--|--|---|--|
| 55825 | Monitor: 12-24 V; Camera: 12V | 7" | Monitor a colori: 7" HD Schermo 16:9; Luminosità 450cd/M ² ; Contrasto: 500:1; multilingua; audio disponibile | Monitor: 800*RGB*480; Camera: PAL:733(H)*493(V) NTSC:733(H)*493(V) | Sensore: CMOS; Linea TV: 600; Lente: 2,5 mm; Illuminazione minima: 0Lux(LED on) | -20°C; +70°C |

MONITOR 7" HD WATERPROOF

MONITOR 7" HD WATERPROOF
 MONITEUR 7 POUCES HD ÉTANCHE
 MONITOR 7" HD WASSERDICHT
 MONITOR HD IMPERMEABLE DE 7 PULGADAS



IP69K



Linee guida
retromarcia
Reverse guidelines

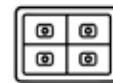

Quad vision



Fino a 4 camere
Up to 4 cameras



10m
Notte/Night



No audio

Articoli a ricambio

0A27320

Supporto di fissaggio che include
due basi a sfera tonde e un braccio
a doppia presa che consente una
regolazione quasi infinita



55802

Camera waterproof 12V per kit
55800, 55804, 55806



84689

Cavo a ricambio 20 m per 80819,
55800, 55804, 55806

| Skù | Tensione nominale / Rated voltage | Monitor / Monitor | Risoluzione / Resolution | Temperatura di esercizio / Operating temperature | Certificazioni / Certifications |
|-------|-----------------------------------|--|--------------------------|--|---------------------------------|
| 55830 | 12-24 V DC | Luminosità:450cd/M2; Contrasto:500:1 / Brightness: 450 cd/m ² ; Contrast: 500:1 | 800RGB(H)*480(V) | -20°C / +70°C | CE, RoHS, UKCA, IP69K |

KIT VIDEOCAMERA WIRELESS 7"

WIRELESS VIDEO CAMERA KIT 7"
 KIT CAMÉRA VIDÉO SANS FIL 7"
 7"-FUNK-VIDEOKAMERA-KIT
 KIT DE VIDEOCÁMARA INALÁMBRICA DE 7"



100 m



Wireless



10m
Notte/Night



1 camera



Visualizzazione
a specchio
Mirror view



Linee guida
retromarcia
Reverse guidelines



No audio



120°
Angolo di visuale
Viewing angle



IP69K

Articoli a ricambio

0A27320

Supporto di fissaggio che include
due basi a sfera tonde e un braccio
a doppia presa che consente una
regolazione quasi infinita



84689

Cavo a ricambio 20 m per 80819,
55800, 55804, 55806

| Skù | Tensione nominale / Rated voltage | Modello / Model | Monitor / Monitor | Risoluzione / Resolution | Camera / Camera | Certificazioni / Certifications |
|-------|-----------------------------------|-----------------|--|--|---|---------------------------------|
| 55808 | 12-24 | 7" | Monitor a colori: 7" TFT LCD 16:9; Luminosità, contrasto, colore regolabili, PAL e NTSC selezione automatica; Multilingua; Audio non disponibile | Monitor: 800*R.G.B.*480 (digitale); Camera: 600TVL | Sensore: 1/3" Color CMOS; 2,4G wireless digitale; Sistema PAL; 18 pz IR LED | CE, RoHS, REACH, IP69K (camera) |

KIT VIDEOCAMERA WIRELESS 7"

WIRELESS VIDEO CAMERA KIT 7"
 KIT CAMÉRA VIDÉO SANS FIL 8
 7"-FUNK-VIDEOKAMERA-KIT
 KIT DE VIDEOCÁMARA INALÁMBRICA DE 7"



Articoli a ricambio

| | | | |
|--|----------------|--|-------|
| | 0A27320 | Supporto di fissaggio che include due basi a sfera tonde e un braccio a doppia presa che consente una regolazione quasi infinita | |
| | 55817 | Camera wireless CMOS waterproof 12-24V per kit 55814, 55815 | 55814 |

| Skù | Tensione nominale / Rated voltage | Modello / Model | Monitor / Monitor | Risoluzione / Resolution | Camera / Camera | Certificazioni / Certifications |
|--------------|-----------------------------------|-----------------|--|--|---|--------------------------------------|
| 55814 | 12-24 | 7" | Monitor a colori: 7" HD; Luminosità 450cd/M ² ; Contrasto: 500:1; Trasmissione radio FH; Radio frequenza: 1HMHz; Potenza di trasmissione 27dBm; Bande di frequenza: 2400-2483MHZ; Multilingua | Monitor: 800*R.G.B.*480; Camera: 976(H)*494(V) | Sensore: CMOS; Banda di frequenza: 2400-2483.5MHZ; Rapporto di onda stazionaria 2:1; Potenza di trasmissione: 20dBm; Modulazione: FSK; Compressione video: MPEG4; Video format PAL/NTSC | CE, RoHS, REACH, RED, IP69K (camera) |

KIT VIDEOCAMERA MAGNETICO WIRELESS 7" AHD CON CAMERA A BATTERIA RICARICABILE

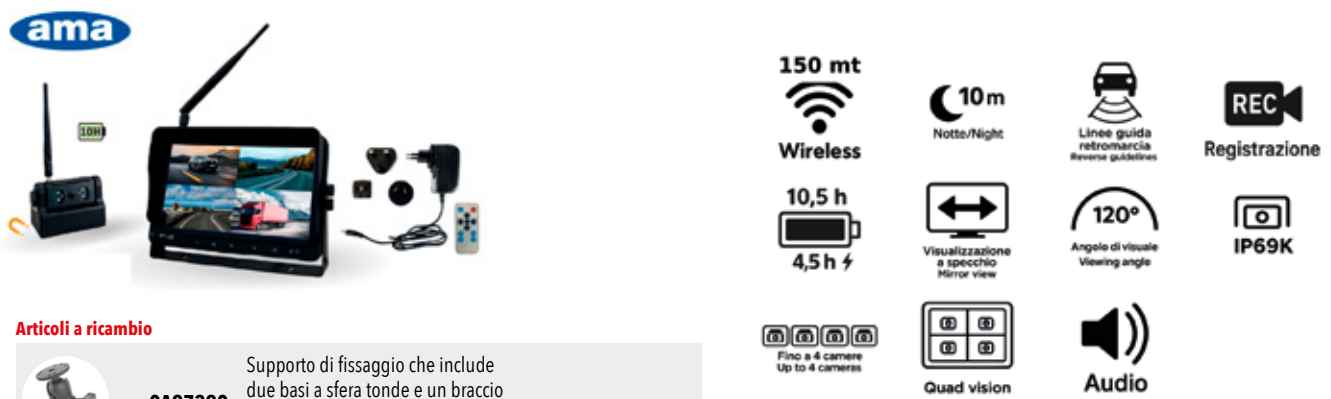
WIRELESS AHD CAMERA MONITOR SYSTEM 7", MAGNETIC CAMERA WITH BUILT-IN RECHARGEABLE BATTERY
 SYSTÈME MONITEUR CAMÉRA AHD SANS FIL 7", CAMÉRA MAGNÉTIQUE AV. BATTERIE RECHARGEABLE INTÉGRÉE
 KABELLOSES AHD-KAMERA-MONITORSYSTEM 7", MAGNETISCHE KAMERA MIT INTEGRIERTEM AKKU
 SISTEMA DE MONITOR DE CÁMARA AHD INALÁMBRICO DE 7", CÁMARA MAGNÉTICA CON BATERÍA RECARGABLE INTEGRAD

Articoli a ricambio

| | | | |
|--|----------------|--|-------|
| | 0A27320 | Supporto di fissaggio che include due basi a sfera tonde e un braccio a doppia presa che consente una regolazione quasi infinita | |
| | 55822 | Camera wireless magnetica a batteria ricaricabile per art. 55821 | 55821 |

| Skù | Tensione nominale / Rated voltage | Modello / Model | Monitor / Monitor | Risoluzione / Resolution | Camera / Camera | Certificazioni / Certifications |
|--------------|-----------------------------------|-----------------|--|--|---|---------------------------------|
| 55821 | Monitor: 12-24V; Camera: 12V | 7" | Monitor a colori: 7" AHD; Luminosità: 450cd/M ² ; Contrasto: 500:1; Spettro espanso: FH; Radio frequenza: 1HMHz; Potenza di trasmissione: 27dBm; Banda di frequenza: 2400-2483MHZ; Modulazione: 16QAM/QPSK/BPSK; Multilingua; Audio disponibile | Monitor: 1024RGB(H)*600(V); Camera: 720P, 1280(H)*720(V) | Sensore: 1/3,7 CMOS; Banda di frequenza: 2400-2483MHZ; Rapporto di onda stazionaria 2:1; Potenza di trasmissione: 20dBm; Modulazione: FSK/GFSK; Spettro espanso: FH; Tempo di ritardo: 18ms Max; Velocità di trasmissione: 25f/s; Compressione video: MPEG4 | CE, RoHS, RED, IP69K (camera) |

KIT VIDEOCAMERA WIRELESS 9"

WIRELESS VIDEO CAMERA KIT 9"

KIT CAMÉRA VIDÉO SANS FIL 8

9"-FUNK-VIDEOKAMERA-KIT

KIT DE VIDEOCÁMARA INALÁMBRICA DE 9"

Articoli a ricambio

| | | | |
|--|----------------|--|-------|
| | 0A27320 | Supporto di fissaggio che include due basi a sfera tonde e un braccio a doppia presa che consente una regolazione quasi infinita | |
| | 55802 | Camera waterproof 12V per kit 55800, 55804, 55806 | |
| | 55807 | Monitor 9" HD 12-24V 16:9 QUAD split monitor per kit 55806 | 55806 |
| | 84689 | Cavo a ricambio 20 m per 80819, 55800, 55804, 55806 | |

| Skù | Tensione nominale / Rated voltage | Tipo / Type | Modello / Model | Monitor / Monitor | Risoluzione / Resolution | Camera / Camera | Certificazioni / Certifications |
|--------------|-----------------------------------|-------------|-----------------|--|--|---|---------------------------------|
| 55806 | Monitor: 12-24V; Camera: 12V | a cavo | 9" | Monitor a colori: 9" HD Schermo 16:9, Luminosità 450cd/M ² ; Contrasto: 500:1, Multilingua, Audio disponibile | Monitor: 800*R.G.B.*480; Camera: PAL, NTSC 733(H)*493(V) | Sensore: CMOS; TVL: 700; Bilanciamento del bianco in automatico; FPS: PAL 50Hz / NTSC: 60Hz | CE, RoHS, REACH, IP69K (camera) |

KIT VIDEOCAMERA WIRELESS 9"

WIRELESS VIDEO CAMERA KIT 9"

KIT CAMÉRA VIDÉO SANS FIL 9

9"-FUNK-VIDEOKAMERA-KIT

KIT DE VIDEOCÁMARA INALÁMBRICA DE 9"

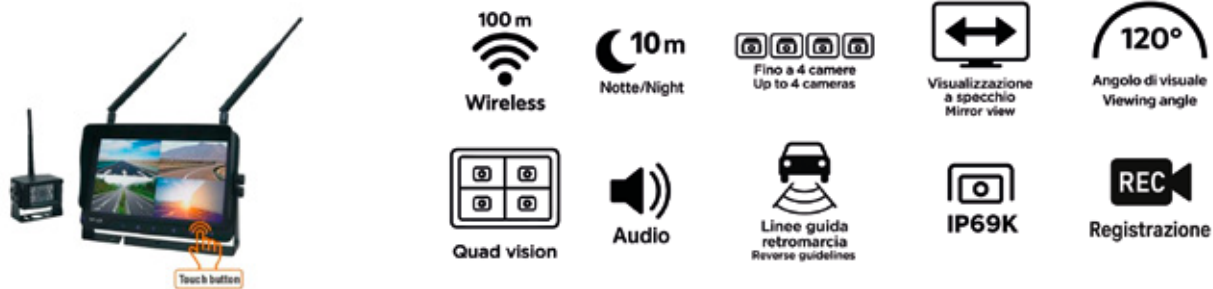
Articoli a ricambio

| | | | |
|--|----------------|--|-------|
| | 0A27320 | Supporto di fissaggio che include due basi a sfera tonde e un braccio a doppia presa che consente una regolazione quasi infinita | |
| | 55817 | Camera wireless CMOS waterproof 12-24V per kit 55814, 55815 | 55814 |

| Skù | Tensione nominale / Rated voltage | Tipo / Type | Modello / Model | Monitor / Monitor | Risoluzione / Resolution | Camera / Camera | Certificazioni / Certifications |
|--------------|-----------------------------------|-------------|-----------------|---|---|--|--------------------------------------|
| 55815 | 12-24 | wireless | 9" | Monitor a colori: 9" HD; Luminosità 450cd/M ² ; Contrasto: 500:1, trasmissione radio FH; Radio frequenza: 1HMHz; Potenza di trasmissione 27dBm; Bande di frequenza: 2400-2483MHZ; Multilingua; Audio disponibile | Monitor: 800*R.G.B.*480; Camera: 976(H)*494(V) | Sensore: CMOS; Banda di frequenza: 2400-2483.5MHZ; Rapporto di onda stazionaria 2:1; Potenza di trasmissione: 20dBm; Video format PAL/NTSC | CE, RoHS, REACH, RED, IP69K (camera) |



Accessori cabina

Cabin accessories

I prodotti recanti il marchio AMA qui indicati sono realizzati da AMA S.p.A. e destinati a essere utilizzati come ricambi adattabili e non originali. I riferimenti a marchi, codici originali e costruttori di terzi, riportati in corrispondenza degli articoli AMA compatibili, hanno esclusivamente la finalità di identificare il modello, l'applicazione o la destinazione d'uso del prodotto, in conformità a quanto previsto dal Regolamento (CE) n. 1400/2002 e dalla normativa vigente in materia di concorrenza e uso lecito dei marchi di terzi. / The products bearing the AMA brand name listed here are manufactured by AMA S.p.A. and are intended for use as adaptable, non-original spare parts. References to trademarks, original codes and third-party manufacturers, shown alongside compatible AMA items, are intended solely to identify the model, application or intended use of the product, in accordance with Regulation (EC) No. 1400/2002 and current legislation on competition and the lawful use of third-party trademarks.

SPAZZOLE TERGICRISTALLI MODELLO METAL AD ARCHETTO

METAL MODEL BRACKET-TYPE WIPER BLADES
 BALAIS D'ESSUIE-GLACE À ARMATURE - MODÈLE METAL
 BÜGELWISCHERBLÄTTER - MODELL METAL
 ESCOBILLAS LIMPIAPARABRISAS CON SOPORTE - MODELO METAL



| SKU | Brand / Brand | Modello / Model | Lunghezza / Length | Linea / Line | Materiali / Material | Contenuto / Content |
|-------|---------------|--------------------------------|--------------------|--------------|--|---|
| 01222 | Hella | Archetto / Bracket wiper blade | 450 mm / 18 in | Metal | Parte gommata rivestita di grafite/ Rubber section with graphite coating | Spazzola + 3 adattatori per ganci / Wiper blade + 3 hook adapters |
| 01223 | Hella | Archetto / Bracket wiper blade | 550 mm / 22 in | Metal | Parte gommata rivestita di grafite/ Rubber section with graphite coating | Spazzola + 2 adattatori per ganci / Wiper blade + 2 hook adapters |
| 01225 | Hella | Archetto / Bracket wiper blade | 600 mm / 24 in | Metal | Parte gommata rivestita di grafite/ Rubber section with graphite coating | Spazzola + 2 adattatori per ganci / Wiper blade + 2 hook adapters |
| 01283 | Hella | Archetto / Bracket wiper blade | 400 mm / 16 in | Metal | Parte gommata rivestita di grafite/ Rubber section with graphite coating | Spazzola + 2 adattatori per ganci / Wiper blade + 2 hook adapters |
| 01284 | Hella | Archetto / Bracket wiper blade | 500 mm / 20 in | Metal | Parte gommata rivestita di grafite/ Rubber section with graphite coating | Spazzola + 2 adattatori per ganci / Wiper blade + 2 hook adapters |
| 69388 | Hella | Archetto / Bracket wiper blade | 350 mm / 14 in | Metal | Parte Gommata rivestita di grafite/ Rubber section with graphite coating | Spazzola + 3 adattatori per ganci / Wiper blade + 3 hook adapters |
| 69389 | Hella | Archetto / Bracket wiper blade | 375 mm / 15 in | Metal | Parte Gommata rivestita di grafite/ Rubber section with graphite coating | Spazzola + 3 adattatori per ganci / Wiper blade + 3 hook adapters |
| 69390 | Hella | Archetto / Bracket wiper blade | 425 mm / 17 in | Metal | Parte Gommata rivestita di grafite/ Rubber section with graphite coating | Spazzola + 3 adattatori per ganci / Wiper blade + 3 hook adapters |
| 69391 | Hella | Archetto / Bracket wiper blade | 475 mm / 19 in | Metal | Parte Gommata rivestita di grafite/ Rubber section with graphite coating | Spazzola + 3 adattatori per ganci / Wiper blade + 3 hook adapters |
| 69392 | Hella | Archetto / Bracket wiper blade | 525 mm / 21 in | Metal | Parte Gommata rivestita di grafite/ Rubber section with graphite coating | Spazzola + 2 adattatori per ganci / Wiper blade + 2 hook adapters |
| 69393 | Hella | Archetto / Bracket wiper blade | 575 mm / 23 in | Metal | Parte Gommata rivestita di grafite/ Rubber section with graphite coating | Spazzola + 2 adattatori per ganci / Wiper blade + 2 hook adapters |
| 69394 | Hella | Archetto / Bracket wiper blade | 650 mm / 26 in | Metal | Parte Gommata rivestita di grafite/ Rubber section with graphite coating | Spazzola + 2 adattatori per ganci / Wiper blade + 2 hook adapters |

SPAZZOLE TERGICRISTALLI CLEANTECH A LAMA PIATTA

CLEANTECH FLAT BLADE WIPER BLADES
BALAIS D'ESSUIE-GLACE CLEANTECH À LAME PLATE
CLEANTECH FLACHBALKEN-WISCHERBLÄTTER
ESCOBILLAS LIMPIAPARABRISAS CLEANTECH DE LÁMINA PLANA



| Skü | Brand / Brand | Modello / Model | Linea / Line | Lunghezza / Length | Contenuto / Content | Note / Notes |
|-------|---------------|--------------------------|--------------|--------------------|---|---|
| 69427 | Hella | Lama piatta / Flat blade | Cleantech | 350 mm / 14 in | Spazzola + 4 adattatori per ganci / Wiper blade + 4 hook adapters | Adatto per superficie curva / Compatible with curved surfaces |
| 69428 | Hella | Lama piatta / Flat blade | Cleantech | 375 mm / 15 in | Spazzola + 2 adattatori per ganci / Wiper blade + 2 hook adapters | Adatto per superficie curva / Compatible with curved surfaces |
| 69429 | Hella | Lama piatta / Flat blade | Cleantech | 400 mm / 16 in | Spazzola + 5 adattatori per ganci / Wiper blade + 5 hook adapters | Adatto per superficie curva / Compatible with curved surfaces |
| 69430 | Hella | Lama piatta / Flat blade | Cleantech | 450 mm / 18 in | Spazzola + 6 adattatori per ganci / Wiper blade + 6 hook adapters | Adatto per superficie curva / Compatible with curved surfaces |
| 69431 | Hella | Lama piatta / Flat blade | Cleantech | 475 mm / 19 in | Spazzola + 5 adattatori per ganci / Wiper blade + 5 hook adapters | Adatto per superficie curva / Compatible with curved surfaces |
| 69432 | Hella | Lama piatta / Flat blade | Cleantech | 500 mm / 20 in | Spazzola + 5 adattatori per ganci / Wiper blade + 5 hook adapters | Adatto per superficie curva / Compatible with curved surfaces |
| 69433 | Hella | Lama piatta / Flat blade | Cleantech | 525 mm / 21 in | Spazzola + 4 adattatori per ganci / Wiper blade + 4 hook adapters | Adatto per superficie curva / Compatible with curved surfaces |
| 69434 | Hella | Lama piatta / Flat blade | Cleantech | 550 mm / 22 in | Spazzola + 7 adattatori per ganci / Wiper blade + 7 hook adapters | Adatto per superficie curva / Compatible with curved surfaces |
| 69435 | Hella | Lama piatta / Flat blade | Cleantech | 600 mm / 24 in | Spazzola + 7 adattatori per ganci / Wiper blade + 7 hook adapters | Adatto per superficie curva / Compatible with curved surfaces |
| 69437 | Hella | Lama piatta / Flat blade | Cleantech | 650 mm / 26 in | Spazzola + 6 adattatori per ganci / Wiper blade + 6 hook adapters | Adatto per superficie curva / Compatible with curved surfaces |
| 69438 | Hella | Lama piatta / Flat blade | Cleantech | 700 mm / 28 in | Spazzola + 5 adattatori per ganci / Wiper blade + 5 hook adapters | Adatto per superficie curva / Compatible with curved surfaces |

SPAZZOLA TERGICRISTALLI 400 MM ATTACCO A DUE VITI

WIPER BLADE 400 MM WITH TWO-SCREW MOUNTING
BALAI D'ESSUIE-GLACE 400 MM AVEC FIXATION À DEUX VIS
WISCHBLATT 400 MM MIT BEFESTIGUNG MIT ZWEI SCHRAUBEN
ESCOBILLA DE LIMPIAPARABRISAS DE 400 MM CON FIJACIÓN DE DOS TORNILLOS



| Skü | Lunghezza / Length | Modello / Model | Note / Notes |
|-------|--------------------|---------------------------------------|------------------------------------|
| 12471 | 400 mm / 16 in | Attacco a due viti / Two-screw fixing | Per vetro curvo / For curved glass |

BRACCI REGOLABILI E FISSI PER TERGICRISTALLI

ADJUSTABLE AND FIXED WIPER ARMS
BRAS D'ESSUIE-GLACE RÉGLABLES ET FIXES
VERSTELLBARE UND FESTE WISCHERARME
BRAZOS DE LIMPIAPARABRISAS AJUSTABLES Y FIJOS



| Skü | Tipo / Type | Attacco / Attachment | Lunghezza minima / Min. length | Lunghezza massima / Max. length |
|--------|-------------------------|----------------------|--------------------------------|---------------------------------|
| 01304 | regolabile / adjustable | A8xM6 | 300 mm | 400 mm |
| 01308 | regolabile / adjustable | A8xM7 | 300 mm | 400 mm |
| 01311 | regolabile / adjustable | A8xM6 | 400 mm | 500 mm |
| A27411 | fisso / fixed | A8xM6 | 550 mm | 550 mm |

BRACCIO PER TERGICRISTALLI 382 MM

WIPER ARM 382 MM
BRAS DE BALAI ESSUIE-GLACE 382 MM
WISCHERARM 382 MM
BRAZO DE LIMPIAPARABRISAS 382 MM



| Skü | Lunghezza / Length | Diametro braccio / Arm diameter | Attacco / Attachment |
|-------|--------------------|---------------------------------|----------------------|
| 12465 | 38,20 cm | 9x3 mm | C10xM8 |

BRACCI PER TERGICRISTALLI PARALLELI

PARALLEL WIPER ARMS
BRAS D'ESSUIE-GLACE PARALLÈLES
PARALLELE ARME FÜR SCHEIBENWISCHER
BRAZOS PARALELOS PARA LIMPIAPARABRISAS



| Skü | Tipo / Type | Diametro braccio / Arm diameter | Attacco / Attachment | Note / Notes | Lunghezza minima / Min. length | Lunghezza massima / Max. length | Prodotti compatibili / Compatible products |
|-------|-------------------------|---------------------------------|---|--|--------------------------------|---------------------------------|--|
| 12467 | pantografo / pantograph | 9x3 mm | Forcella Ti=57,5 2 viti C10XM8-B/M8 / T-fork, center distance 57.5, with 2 screws C10XM8-B/M8 | | 453 mm | 533 mm | 12461 |
| 12468 | pantografo / pantograph | 9x3 mm | Forcella Ti=57,5 2Viti C10XM8-B/M8 / T-fork, center distance 57.5, with 2 screws C10XM8-B/M8 | Con spruzzatore lato sx / With left-side washer nozzle | 475 mm | 526 mm | 12461 |

MOTORE TERGICRISTALLI 12V ANGOLO 110°

WIPER MOTOR 12V, 110° SWEEP ANGLE
MOTEUR D'ESSUIE-GLACE 12V, ANGLE DE BALAYAGE 110°
12V-WISCHERMOTOR, WISCHWINKEL 110°
MOTOR DE LIMPIAPARABRISAS 12V, ÁNGULO DE BARRIDO 110°



| Skü | Tensione nominale / Rated voltage | Angolo / Angle | Lunghezza massima / Max. length | Attacco out / Attack out | A | B | Note / Notes |
|-------|-----------------------------------|----------------|---------------------------------|--------------------------|--------|-------|--|
| 12459 | 12 V | 110 ° | 500 mm | M10x6mm | 115 mm | 99 mm | Posizione di parcheggio non inclusa. Con interruttore / Without parking position |

MOTORI TERGICRISTALLI ATTACCO A8XM6

WIPER MOTORS WITH A8XM6 SHAFT
 MOTEURS D'ESSUIE-GLACE AVEC AXE A8XM6
 WISCHERMOTOREN MIT A8XM6-ANSCHLUSS
 MOTORES DE LIMPIAPARABRISAS CON EJE A8XM6



| Skü | Tensione nominale / Rated voltage | Angolo / Angle | Lunghezza massima / Max. length | Attacco out / Attack out | A | B | Prodotti compatibili / Compatible products |
|-------|-----------------------------------|----------------|---------------------------------|--------------------------|--------|-------|--|
| 01340 | 12 V | 105 ° | 575 mm | A8xM6 | 67 mm | 42 mm | 01304,01311 |
| 01344 | 12 V | 105 ° | 575 mm | A8xM6 | 119 mm | 94 mm | 01304,01311 |
| 12723 | 12 V | 85 ° | 575 mm | A8xM6 | 67 mm | 42 mm | 01304,01311 |

MOTORE TERGICRISTALLI 12V ANGOLO 90°

WIPER MOTOR 12V, 90° SWEEP ANGLE
 MOTEUR D'ESSUIE-GLACE 12V, ANGLE DE BALAYAGE 90°
 12V-WISCHERMOTOR, WISCHWINKEL 90°
 MOTOR DE LIMPIAPARABRISAS 12V, ÁNGULO DE BARRIDO 90°



| Skü | Tensione nominale / Rated voltage | Angolo / Angle | Attacco / Attachment | Note / Notes | Prodotti compatibili / Compatible products |
|-------|-----------------------------------|----------------|----------------------|-----------------------------|--|
| 12461 | 12 V | 90 ° | A10XM8 | Una velocità / Single speed | 12467,12468 |

KIT LAVACRISTALLI

WINDSCREEN WASHER KIT
 KIT LAVE-GLACE
 SCHEIBENWASCHANLAGEN-KIT
 KIT DE LAVADO DE PARABRISAS



| Skü | Descrizione / Description | Tipo / Type |
|-------|---|---|
| 57687 | Borsa con elettropompa per lavacrystallo 12V 2 LT, 250x270mm, interasse occhielli di fissaggio 125 mm / Bag with electropump for windshield washer 12V 2 LT,250x270mm,interaxis fixing eyelets 125 mm | borsa con elettropompa / bag with electric pump |

ACCENDISIGARI 12V



12V CIGARETTE LIGHTER
 ALLUME-CIGARE 12V
 ZIGARETTENANZÜNDER 12V
 ENCENDEDOR DE CIGARRILLOS 12V



| Skü | Tensione nominale / Rated voltage | Diametro di foratura / Drilling diameter | Temperatura di esercizio / Operating temperature | Note / Notes |
|-------|--------------------------------------|---|---|---|
| 55423 | 12V | 28 mm | -20°C a +55°C | Dopo 10 secondi: 480°C; dopo 20 secondi: 380°C / After 10 seconds: 480 °C; after 20 seconds: 380 °C |

PLAFONIERA

CEILING LIGHT
 PLAFONNIER
 DECKENLEUCHTE
 LÁMPARA DE TECHO

| Skü | Tipo luce / Light type | Tensione nominale / Rated voltage | Dimensioni / Dimensions | Materiale lente / Lens material | Corpo faro / Light body | Modello / Model | Prodotti compatibili / Compatible products | |
|-------|---|--------------------------------------|----------------------------|------------------------------------|----------------------------|-----------------------------------|--|-------------|
| 55305 |  | LED | 12-24 V | 343x33 mm | Acrilico / Acrylic lens | Alluminio / Alumi- num housing | Con interruttore. Rota- zione luce 180° / With switch. 180° light rotation | |
| 55787 |  | Alogeno / Halogen | 12 o 24 V | 136x37,4x70,7 | PC+ABS | PC+ABS | accensione a pressione / push ON/OFF | 00526,12581 |



Alternatori e regolatori

Alternators and voltage
regulators

I prodotti recanti il marchio AMA qui indicati sono realizzati da AMA S.p.A. e destinati a essere utilizzati come ricambi adattabili e non originali. I riferimenti a marchi, codici originali e costruttori di terzi, riportati in corrispondenza degli articoli AMA compatibili, hanno esclusivamente la finalità di identificare il modello, l'applicazione o la destinazione d'uso del prodotto, in conformità a quanto previsto dal Regolamento (CE) n. 1400/2002 e dalla normativa vigente in materia di concorrenza e uso lecito dei marchi di terzi. / The products bearing the AMA brand name listed here are manufactured by AMA S.p.A. and are intended for use as adaptable, non-original spare parts. References to trademarks, original codes and third-party manufacturers, shown alongside compatible AMA items, are intended solely to identify the model, application or intended use of the product, in accordance with Regulation (EC) No. 1400/2002 and current legislation on competition and the lawful use of third-party trademarks.

ALTERNATORI DI CORRENTE

CURRENT ALTERNATORS
 ALTERNATEURS DE COURANT
 STROMGENERATOREN
 ALTERNADORES DE CORRIENTE



| Sku | Tipo / Type | Rif. Orig. | |
|-------|---------------|------------|---|
| | | Brand | Cod. Originale |
| 01456 | faston 6,3 mm | LOMBARDINI | 1157153/154, 283.1156.090, 30521156090, 1157153, 1157-153 |
| | | RUGGERINI | 2410 |
| | | SLANZI | 01409 |

REGOLATORI

VOLTAGE REGULATORS
 RÉGULATEURS DE TENSION
 SPANNUNGSREGLER
 REGULADORES DE VOLTAJE

Articoli a ricambio



60290

Blocchetto 66,6x27 mm per regolatori art. 01465 - 60289

| Sku | Tensione nominale / Rated voltage | Descrizione / Description |
|-------|-----------------------------------|---|
| 01465 | 12 V | Regolatore 12V Controfase con luce spia carica batteria e segnale W / Regulator 12V Opposite with battery charge warning light and signal W |
| 60289 | 12 V | Regolatore 12V Paralelo con luce spia carica batteria e segnale W / Regulator 12V Parallel with charging battery warning light and signal W |



A.M.A. S.p.A.
Accessori Macchine Agricole

Via Puccini, 28 - 42018 San Martino in Rio, RE (Italy)
Tel +39 0522 636911 - Fax +39 0522 695753
www.ama.it - ama@ama.it



**AZIENDA CON
SISTEMA DI GESTIONE
CERTIFICATO DA DNV GL
= ISO 9001 =
= ISO 14001 =**



SCARICA IL CATALOGO

e consultalo comodamente dal tuo PC.

DOWNLOAD THE CATALOGUE

and keep it handy on your PC.

