

# Indicatori livello carburante e sensori

## Fuel Level Gauges & Sensors



CATALOGO TECNICO  
TECHNICAL CATALOGUE

**ama**  
**ZMEL**

### G31114 - SENSORE CON FISSAGGIO A 6 VITI (Ø60,3 MM) CON TUBI CARBURANTE

G31114 - 6 screws (Ø60,3 mm) fixation sensor with fuel lines

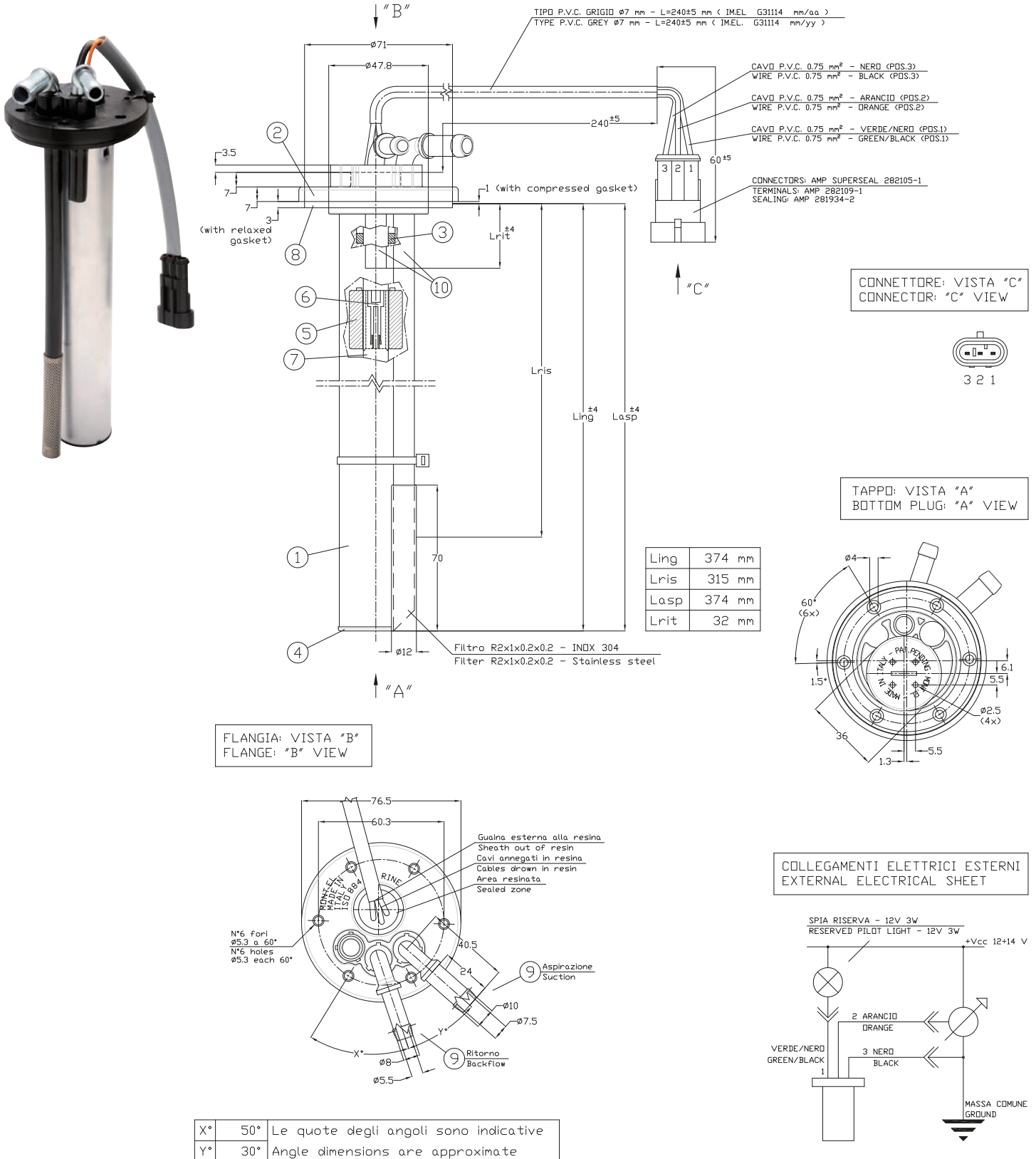

# INDICATORI LIVELLO CARBURANTE

## FUEL LEVEL GAUGES



### G31114 - SENSORE CON FISSAGGIO A 6 VITI (Ø60,3 MM) CON TUBI CARBURANTE

G31114 - 6 screws (ø60,3 mm) fixation sensor with fuel lines

Distinta materiali / Material list				
Rif. / Ref.	Descrizione / Part description	N. Pz. / Q.Ty	Materiale / Material	Note / Notes
1	Corpo sonda Gauge body	1	Alluminio ew-6060 t6 Aluminium ew-6060 t6	
2	Flangia Flange	1	Pa66 rinforzato vetro Pa66 glass reinforced	Colore nero Black color
3	Guarnizione interna Internal gasket	1	Viton Viton	Colore nero Black color
4	Tappo Bottom plug	1	Pa66 rinforzato vetro Pa66 glass reinforced	Colore nero Black color
5	Galleggiante Float	1	Pa espansa Pa expanded	Colore naturale Natural color
6	Contatto strisciante Sliding contact	1	Bronzo fosforoso Phosphorous bronze	Doratura Gold plating
7	Circuito stampato Printed circuit	1	Fr4 Fr4	Doratura Gold plating
8	Guarnizione esterna External gasket	1	Nbr70 resistente ai combustibili Nbr70 fuel resistance	Colore nero Black color
9	Aspirazione/ritorno Suction/backflow	2	Acciaio zincato Steel with zinc protection	
10	Tubo aspirazione/ritorno Suct./Backflow tube	2	Pa11 - ø10x8 Pa11 - ø10x8	Colore nero Black color

Specifiche tecniche / Technical specifications					
Lev.	Fuel level (f)			Resistance [Ω]	Imax [Ma]
	From [mm]	To	[Mm]		
1	0,0		64,0	5,25 ± 1,75	145
2	64,0		109,0	25,25 ± 2,75	100
3	109,0		151,5	45,25 ± 3,75	100
4	151,5		166,0	65,25 ± 4,75	70
5	166,0		180,5	75,25 ± 5,25	70
6	180,5		195,0	90,50 ± 6,00	70
7	195,0		209,5	105,25 ± 6,75	70
8	209,5		220,0	120,50 ± 7,50	70
9	220,0		230,5	135,50 ± 8,50	70
10	230,5		241,0	150,50 ± 9,00	70
11	241,0		256,5	170,50 ± 10,00	70
12	256,5		284,0	190,50 ± 11,00	70
13	284,0		317,0	223,75 ± 12,75	55
14	317,0		349,0	270,50 ± 15,00	45
15	349,0		374,0	332,75 ± 18,25	40
	374,0	<-	LING		
	389,0	<-	LTOT		
	315,0	<-	LRIS		

### G31134 - SENSORE CON FISSAGGIO A 6 VITI (Ø60,3 MM) CON TUBI CARBURANTE

G31134 - 6 screws (Ø60,3 mm) fixation sensor with fuel lines

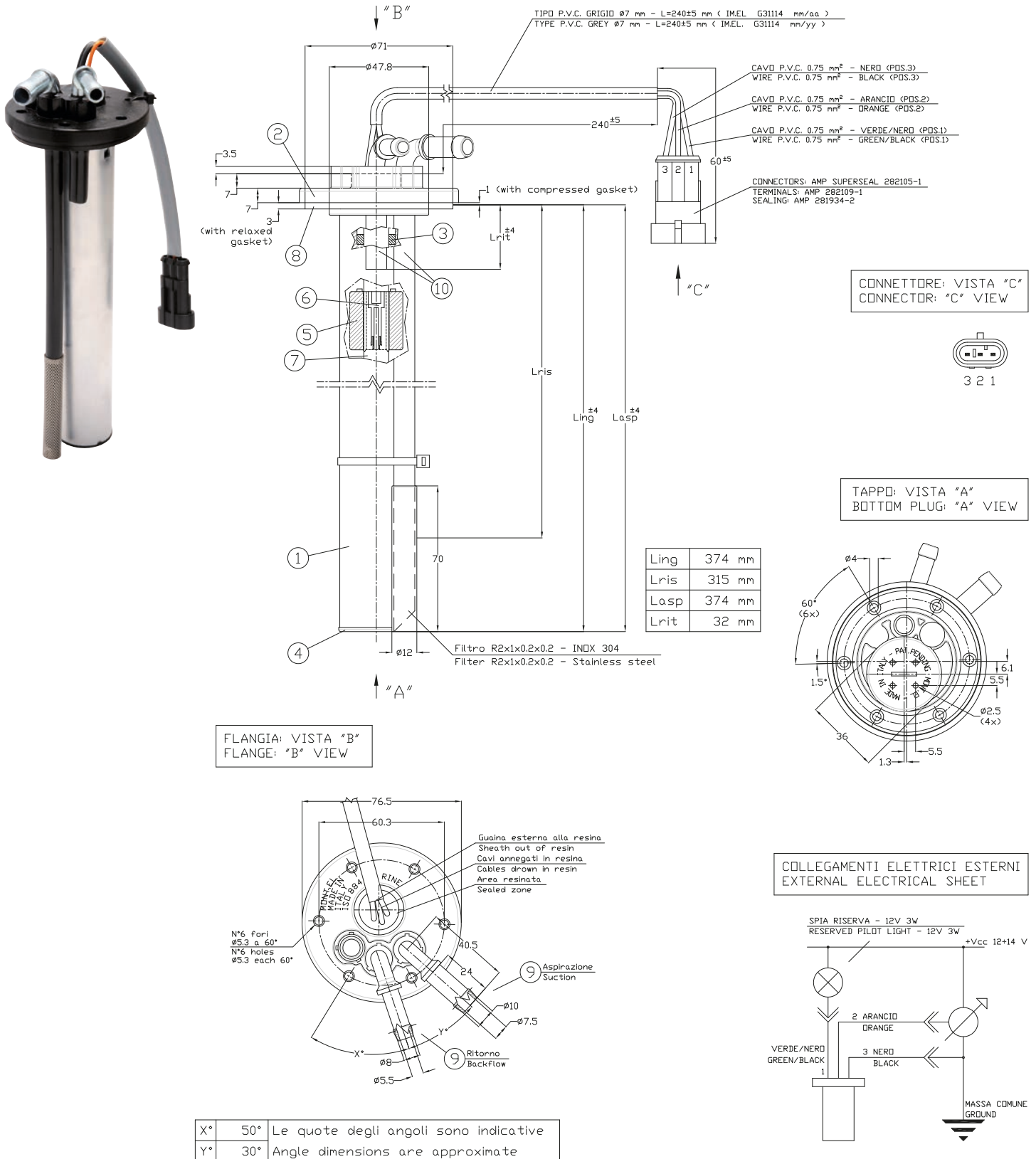

# INDICATORI LIVELLO CARBURANTE

## FUEL LEVEL GAUGES



### G31134 - SENSORE CON FISSAGGIO A 6 VITI (Ø60,3 MM) CON TUBI CARBURANTE

G31134 - 6 screws (Ø60,3 mm) fixation sensor with fuel lines

Distinta materiali / Material list				
Rif. / Ref.	Descrizione / Part description	N. Pz. / Q.Ty	Materiale / Material	Note / Notes
1	Corpo sonda Gauge body	1	Alluminio ew-6060 t6 Aluminium ew-6060 t6	
2	Flangia Flange	1	Pa66 rinforzato vetro Pa66 glass reinforced	Colore nero Black color
3	Guarnizione interna Internal gasket	1	Viton Viton	Colore nero Black color
4	Tappo Bottom plug	1	Pa66 rinforzato vetro Pa66 glass reinforced	Colore nero Black color
5	Galleggiante Float	1	Pa espansa Pa expanded	Colore naturale Natural color
6	Contatto strisciante Sliding contact	1	Bronzo fosforoso Phosphorous bronze	Doratura Gold plating
7	Circuito stampato Printed circuit	1	Fr4 Fr4	Doratura Gold plating
8	Guarnizione esterna External gasket	1	Nbr70 resistente ai combustibili Nbr70 fuel resistance	Colore nero Black color
9	Aspirazione/ritorno Suction/backflow	2	Acciaio zincato Steel with zinc protection	
10	Tubo aspirazione/ritorno Suct./Backflow tube	2	Pa11 - Ø10x8 Pa11 - Ø10x8	Colore nero Black color

Specifiche tecniche / Technical specifications					
Lev.	Fuel level (f)			Resistance [Ω]	Imax [Ma]
	From [mm]		To [Mm]		
1	0,0	→	38,3	5,25 ± 2,25	145
2	38,3	→	65,6	25,25 ± 3,25	100
3	65,6	→	93,6	45,25 ± 4,25	100
4	93,6	→	121,6	65,25 ± 5,25	70
5	121,6	→	154,1	80,50 ± 6,00	70
6	154,1	→	186,1	100,50 ± 7,00	70
7	186,1	→	218,1	120,50 ± 8,00	70
8	218,1	→	250,1	135,50 ± 9,00	70
9	250,1	→	270,1	150,50 ± 9,50	70
10	270,1	→	290,1	170,50 ± 10,50	70
11	290,1	→	310,1	190,50 ± 11,50	70
12	310,1	→	330,1	210,50 ± 12,50	70
13	330,1	→	359,6	237,50 ± 14,00	60
14	359,6	→	390,1	284,75 ± 16,25	45
15	390,1	→	415,6	331,75 ± 18,75	45
	415,6	→	Ling		
	355,6	→	Lris		
	415,6	→	Lasp		
	32,0	→	Lrit		

G31835

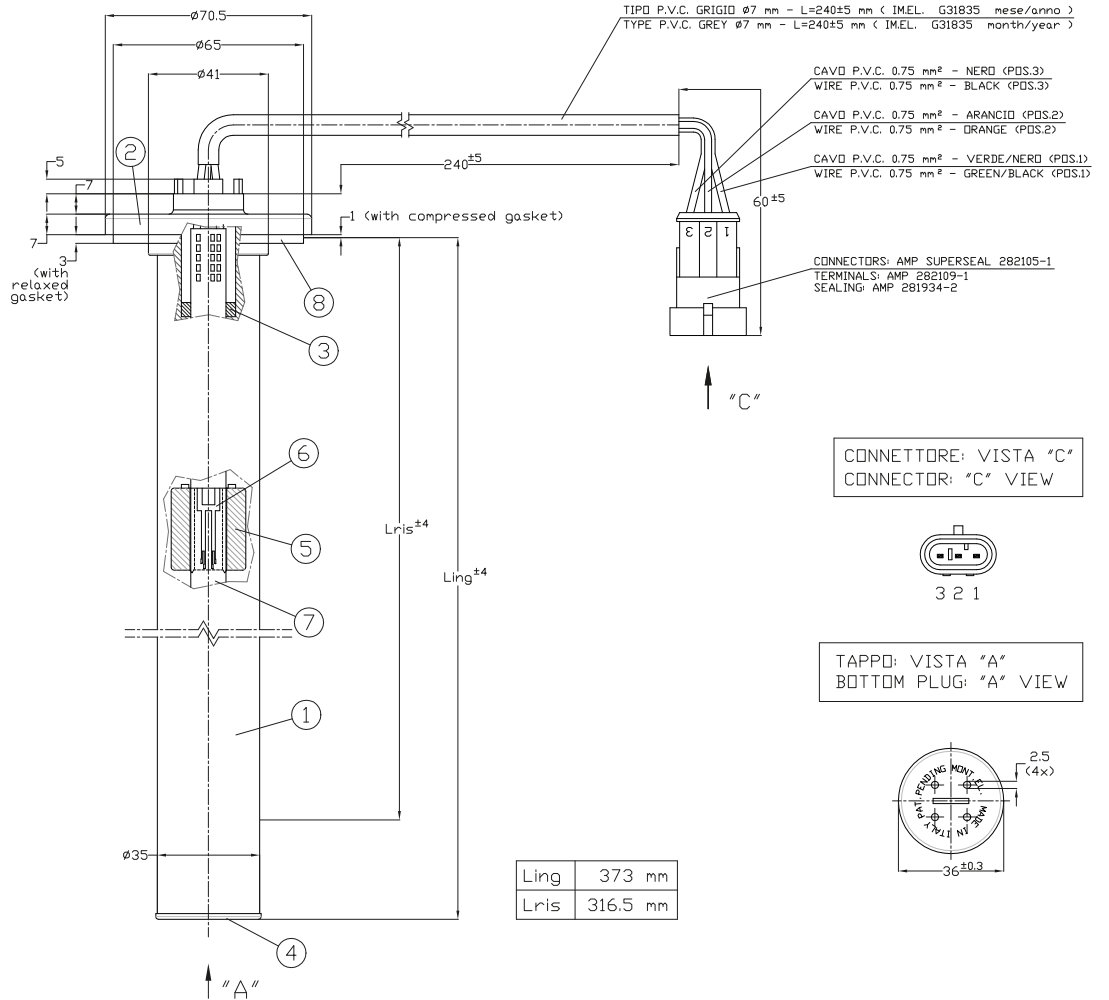

FLANGIA: VISTA "B"  
 FLANGE: "B" VIEW

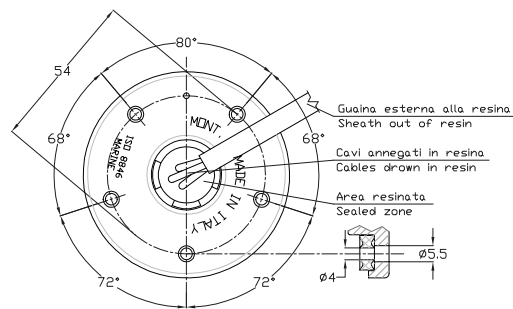

COLLEGAMENTI ELETTRICI ESTERNI  
 EXTERNAL ELECTRICAL SHEET

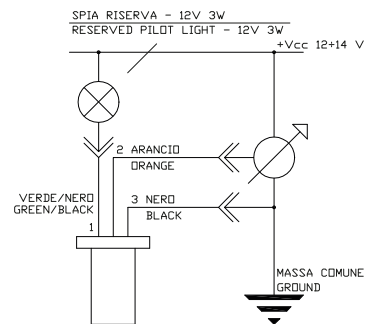

# INDICATORI LIVELLO CARBURANTE

## FUEL LEVEL GAUGES



G31835

Distinta materiali / Material list				
Rif. / Ref.	Descrizione / Part description	N. Pz. / Q.Ty	Materiale / Material	Note / Notes
1	Corpo sonda Gauge body	1	Alluminio ew-6060 t6 Aluminium ew-6060 t6	
2	Flangia Flange	1	Pa66 rinforzato vetro Pa66 glass reinforced	Colore nero Black color
3	Guarnizione interna Internal gasket	1	Viton Viton	Colore verde Green color
4	Tappo Bottom plug	1	Pa66 rinforzato vetro Pa66 glass reinforced	Colore nero Black color
5	Galleggiante Float	1	Pa espansa Pa expanded	Colore naturale Natural color
6	Contatto strisciante Sliding contact	1	Bronzo fosforoso Phosphorous bronze	Doratura Gold plating
7	Circuito stampato Printed circuit	1	Fr4 Fr4	Doratura Gold plating
8	Guarnizione Gasket	1	Nbr70 resistente ai combustibili Nbr70 fuel resistance	Hardness 70 ± 5 Sh.A
9				
10				

Specifiche tecniche / Technical specifications					
Lev.	Fuel level (f)			Resistance [Ω]	Imax [Ma]
	From [mm]	To	[Mm]		
1	0,0		53,0	1,00 ± 1,00	350
2	53,0		90,7	3,00 ± 1,50	300
3	90,7		118,0	7,75 ± 1,75	205
4	118,0		144,0	12,50 ± 2,00	145
5	144,0		163,3	17,00 ± 2,50	145
6	163,3		182,6	21,75 ± 2,75	145
7	182,6		201,9	26,25 ± 2,75	145
8	201,9		221,2	31,00 ± 3,00	145
9	221,2		241,9	35,75 ± 3,25	145
10	241,9		262,6	40,50 ± 3,50	145
11	262,6		283,3	45,25 ± 3,75	145
12	283,3		304,0	50,00 ± 4,00	145
13	304,0		321,0	54,75 ± 4,25	145
14	321,0		348,0	59,50 ± 4,50	145
15	348,0		373,0	66,50 ± 5,00	120
	373,0	<-	LING		
	388,0	<-	LTOT		
	316,5	<-	LRIS		

G31137

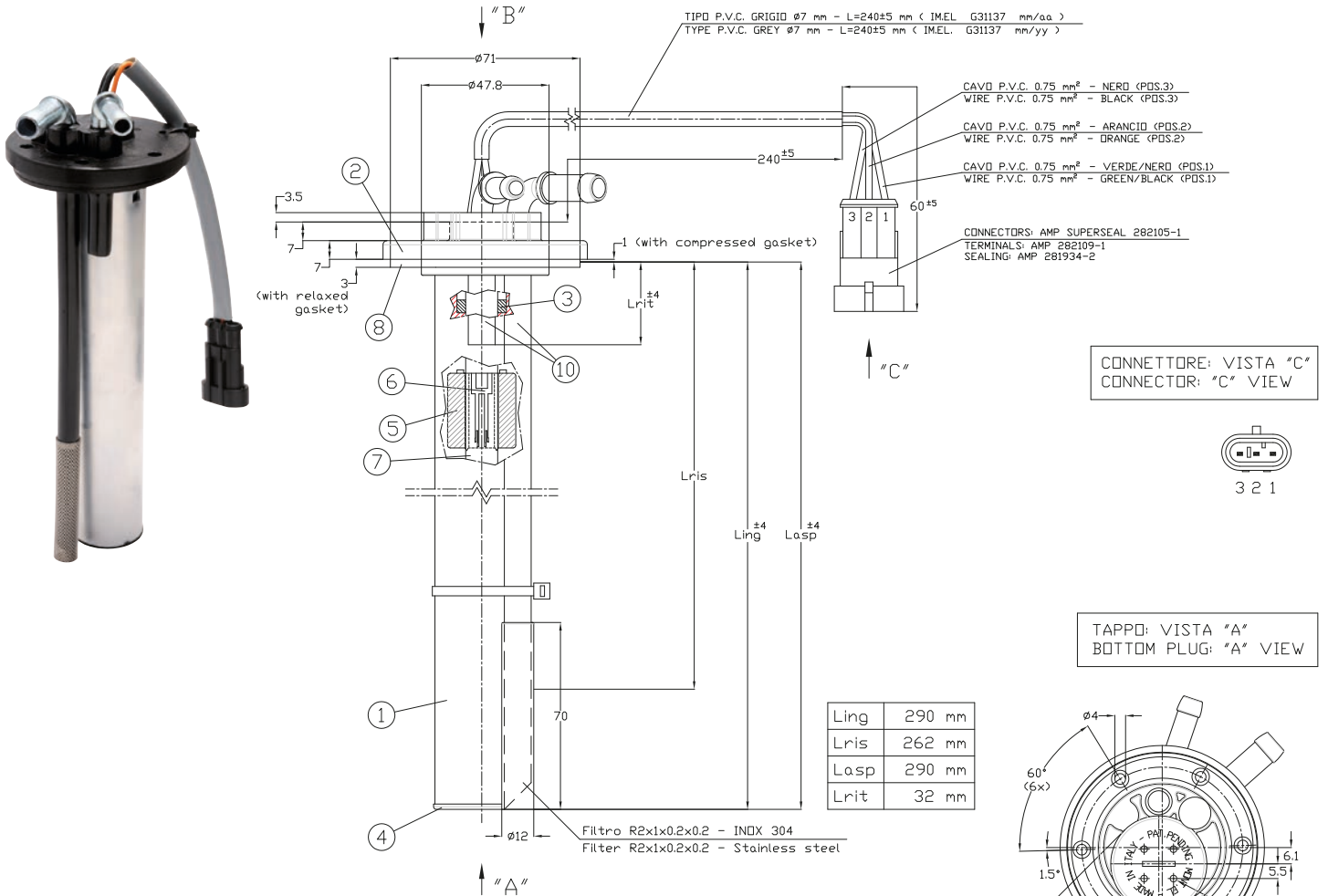

FLANGIA: VISTA "B"  
 FLANGE: "B" VIEW

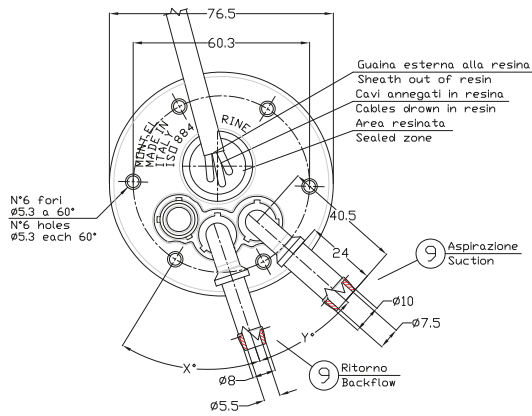

X°	50°	Le quote degli angoli sono indicative
Y°	30°	Angle dimensions are approximate

COLLEGAMENTI ELETTRICI ESTERNI  
 EXTERNAL ELECTRICAL SHEET

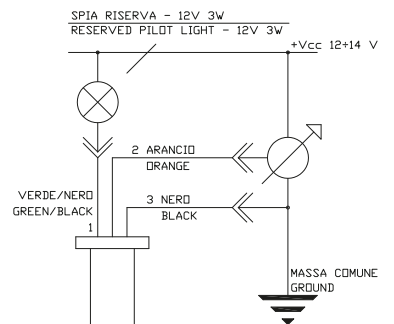



# INDICATORI LIVELLO CARBURANTE

## FUEL LEVEL GAUGES



G31137

Distinta materiali / Material list				
Rif. / Ref.	Descrizione / Part description	N. Pz. / Q.Ty	Materiale / Material	Note / Notes
1	Corpo sonda Gauge body	1	Alluminio ew-6060 t6 Aluminium ew-6060 t6	
2	Flangia Flange	1	Pa66 rinforzato vetro Pa66 glass reinforced	Colore nero Black color
3	Guarnizione interna Internal gasket	1	Viton Viton	Colore nero Black color
4	Tappo Bottom plug	1	Pa66 rinforzato vetro Pa66 glass reinforced	Colore nero Black color
5	Galleggiante Float	1	Pa espansa Pa expanded	Colore naturale Natural color
6	Contatto strisciante Sliding contact	1	Bronzo fosforoso Phosphorous bronze	Doratura Gold plating
7	Circuito stampato Printed circuit	1	Fr4 Fr4	Doratura Gold plating
8	Guarnizione esterna External gasket	1	Nbr70 resistente ai combustibili Nbr70 fuel resistance	Colore nero Black color
9	Aspirazione/ritorno Suction/Backflow	2	Acciaio zincato Steel with zinc protection	
10	Tubo aspiraz./Ritorno Suct./Backflow tube	2	PA11 - Ø10x8 PA11 - Ø10x8	Colore nero Black color

Specifiche tecniche / Technical specifications					
Lev.	Fuel level (f)			Resistance [Ω]	Imax [Ma]
	From [mm]	To	[Mm]		
1	0.0	→	41.2	5.25 ± 2.25	145
2	41.2	→	55.9	25.25 ± 3.25	100
3	55.9	→	73.3	45.25 ± 4.25	100
4	73.3	→	90.7	65.25 ± 5.25	70
5	90.7	→	108.1	75.25 ± 5.75	70
6	108.1	→	125.5	90.25 ± 6.25	70
7	125.5	→	142.9	105.25 ± 7.25	70
8	142.9	→	160.3	120.50 ± 8.00	70
9	160.3	→	177.7	135.25 ± 8.75	70
10	177.7	→	195.1	150.50 ± 9.50	70
11	195.1	→	212.5	170.50 ± 10.50	70
12	212.5	→	229.9	190.50 ± 11.50	70
13	229.9	→	247.4	223.50 ± 13.00	55
14	247.4	→	265.0	270.50 ± 15.50	45
15	265.0	→	290.0	332.50 ± 18.50	40
	290.0	→	Ling		
	262.0	→	Lris		
	290.0	→	Lasp		
	32.0	→	Lrit		

G31211-01

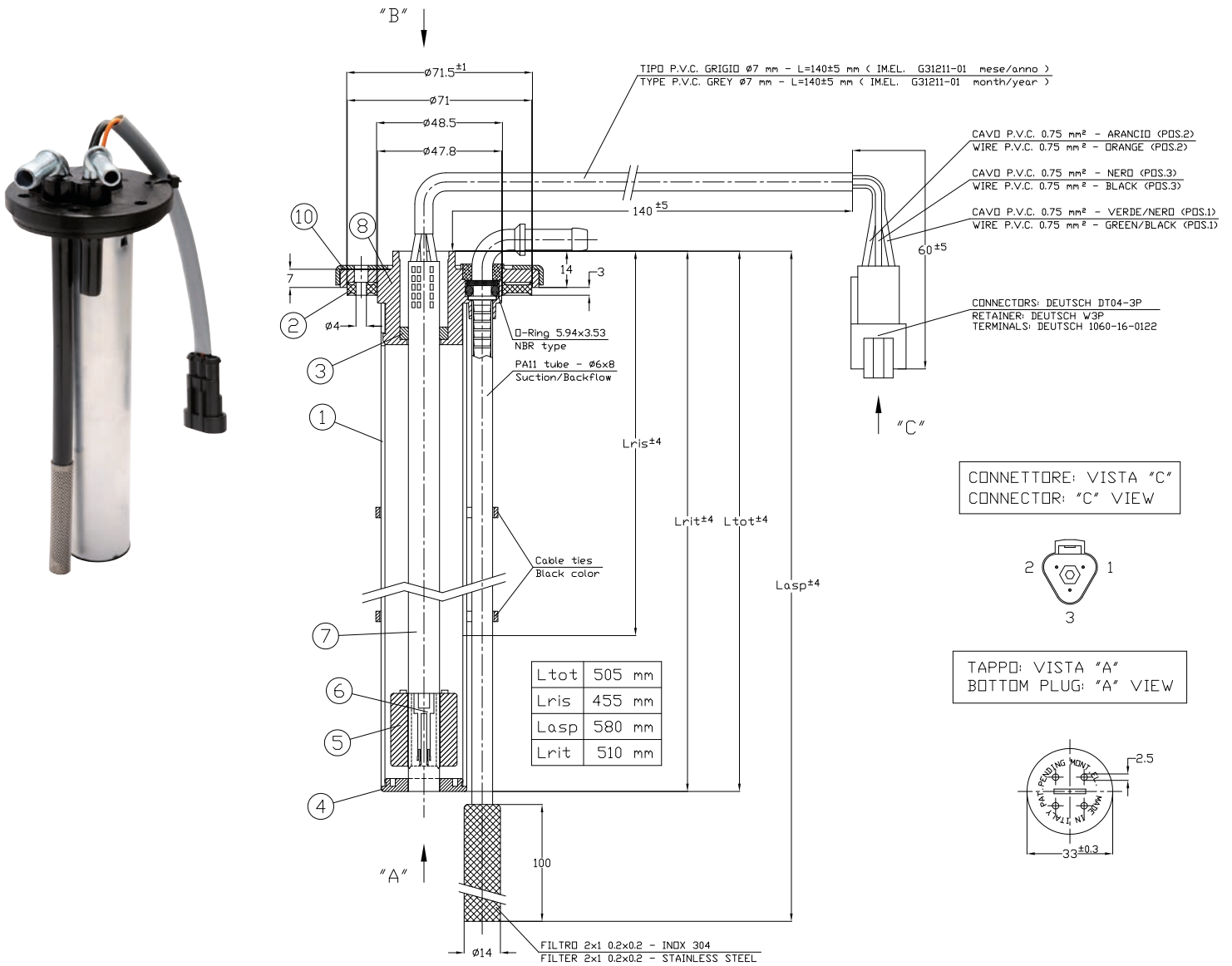

FLANGIA: VISTA "B"  
 FLANGE: "B" VIEW

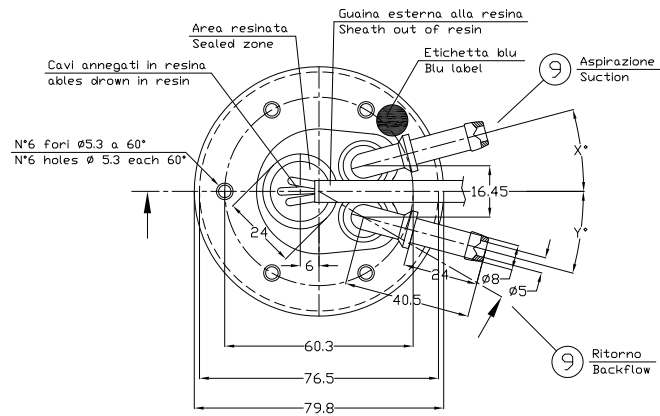

COLLEGAMENTI ELETTRICI ESTERNI  
 EXTERNAL ELECTRICAL SHEET

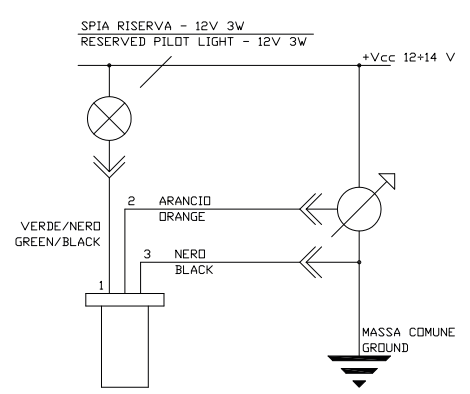

X° ~0° Le quote degli angoli sono indicative  
 Y° ~0° Angle dimensions are approximate

# INDICATORI LIVELLO CARBURANTE

FUEL LEVEL GAUGES



G31211-01

Distinta materiali / Material list				
Rif. / Ref.	Descrizione / Part description	N. Pz. / Q.Ty	Materiale / Material	Note / Notes
1	Corpo sonda Gauge body	1	PVC PVC	Colore nero Black color
2	Guarnizione Gasket	1	Mescola TB2-71 (Tipo NBR) Mixture TB2-71 (NBR Type)	Hardness 70 ±5 Sh.A
3	Guarnizione interna Internal gasket	1	Viton Viton	
4	Tappo Bottom plug	1	PVC PVC	Colore grigio Grey color
5	Galleggiante Float	1	Pa espansa Pa expanded	
6	Contatto strisciante Sliding contact	1	Bronzo fosforoso Phosphorous bronze	Doratura Gold plating
7	Circuito stampato Printed circuit	1	Fr4 Fr4	Doratura Gold plating
8	Flangia Flange	1	PA6 30% rinforzato vetro PA6 30% glass reinforced	Colore nero Black color
9	Aspirazione/ritorno Suction/Backflow	2	Acciaio tropicalizzato Steel with wether protection	
10	Controflangia Top flange	1	FePO2 Tropicalizzato FePO2 With wether protection	

Specifiche tecniche / Technical specifications			
Livello Lev.		Resistenza in uscita Sender unit output [Ω]	Max corrente ammessa Max current intensity [mA]
1	FULL	4.5 < R < 6.5	145
2		23.5 < R < 27.5	100
3		42.5 < R < 48.5	100
4	3/4	61.5 < R < 69.5	70
5		71.0 < R < 80.0	70
6		85.0 < R < 95.5	70
7		99.5 < R < 111.5	70
8	HALF	113.5 < R < 127.0	70
9		128.0 < R < 143.0	70
10		142.5 < R < 159.0	70
11		161.5 < R < 180.0	70
12	1/4	180.5 < R < 201.0	70
13		211.5 < R < 235.5	55
14		256.5 < R < 285.0	45
15	EMPTY	315.5 < R < 350.0	40

G31603

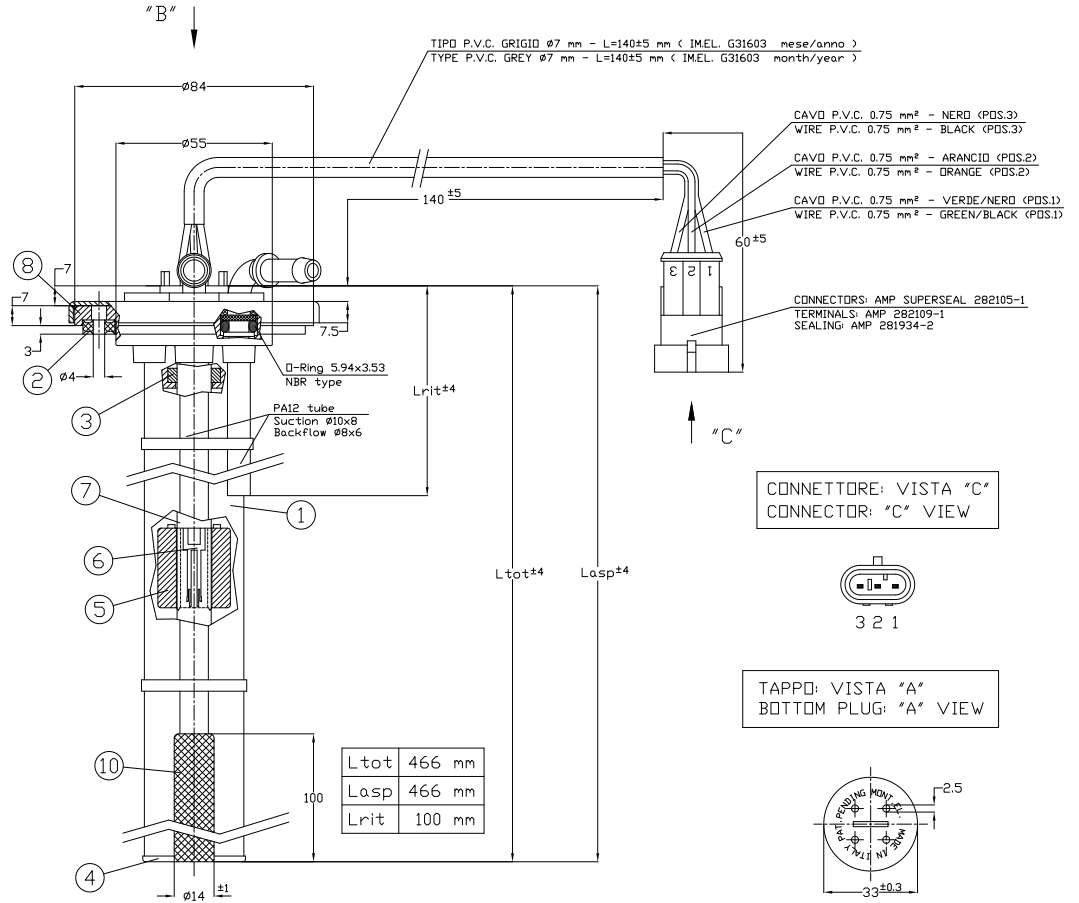

FLANGIA: VISTA "B"  
 FLANGE: "B" VIEW

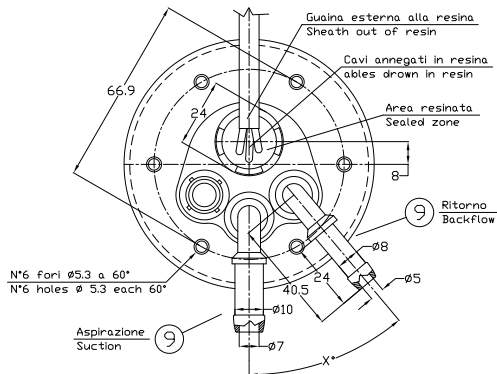

X°	40°	Le quote degli angoli sono indicative
Y°	n.p.	Angle dimensions are approximate

COLLEGAMENTI ELETTRICI ESTERNI  
 EXTERNAL ELECTRICAL SHEET

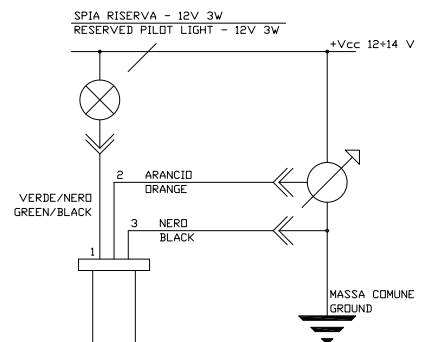

# INDICATORI LIVELLO CARBURANTE

## FUEL LEVEL GAUGES



G31603

Distinta materiali / Material list				
Rif. / Ref.	Descrizione / Part description	N. Pz. / Q.Ty	Materiale / Material	Note / Notes
1	Corpo sonda Gauge body	1	Alluminio Aluminium	
2	Guarnizione Gasket	1	Mescola TB2-71 (tipo NBR) Mixture TB2-71 (NBR type)	Hardness 70 ±5 Sh.A
3	Guarnizione interna Internal gasket	1	Viton Viton	
4	Tappo Bottom plug	1	Pa6 30% rinforzato vetro Pa6 30% glass reinforced	Colore nero Black color
5	Galleggiante Float	1	Pa espansa Pa expanded	
6	Contatto strisciante Sliding contact	1	Bronzo fosforoso Phosphorous bronze	Doratura Gold plating
7	Circuito stampato Printed circuit	1	Fr4 Fr4	Doratura Gold plating
8	Flangia Flange	1	Pa6 30% rinforzato vetro Pa6 30% glass reinforced	Colore nero Black color
9	Aspirazione/ritorno Suction/backflow	2	Acciaio tropicalizzato Steel with wether protection	
10	Filtro Filter	1	Inox 304 Inox 304	Filtering 2x1 0.2x0.2

Specifiche tecniche / Technical specifications					
Lev.	Fuel level (f)			Resistance [Ω]	Imax [Ma]
	From [mm]		To [Mm]		
1	0,0	→	38,3	5,25 ± 2,25	145
2	38,3	→	65,6	25,25 ± 3,25	100
3	65,6	→	93,6	45,25 ± 4,25	100
4	93,6	→	121,6	65,25 ± 5,25	70
5	121,6	→	154,1	80,50 ± 6,00	70
6	154,1	→	186,1	100,50 ± 7,00	70
7	186,1	→	218,1	120,50 ± 8,00	70
8	218,1	→	250,1	135,50 ± 9,00	70
9	250,1	→	270,1	150,50 ± 9,50	70
10	270,1	→	290,1	170,50 ± 10,50	70
11	290,1	→	310,1	190,50 ± 11,50	70
12	310,1	→	330,1	210,50 ± 12,50	70
13	330,1	→	359,6	237,50 ± 14,00	60
14	359,6	→	390,1	284,75 ± 16,25	45
15	390,1	→	415,6	331,75 ± 18,75	45
	415,6	→	Ling		
	355,6	→	Lris		
	415,6	→	Lasp		
	32,0	→	Lrit		

G31826

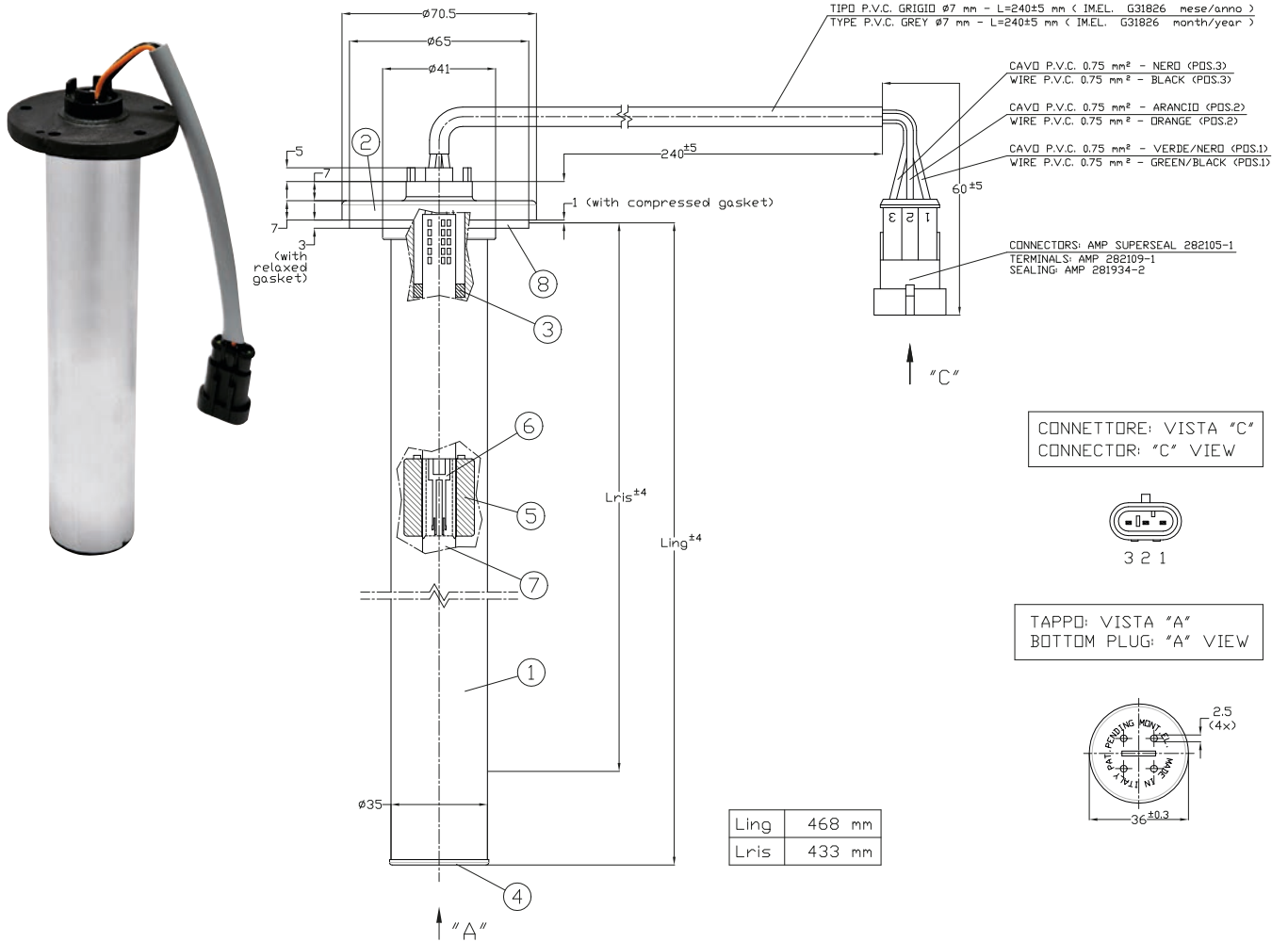

FLANGIA: VISTA "B"  
 FLANGE: "B" VIEW

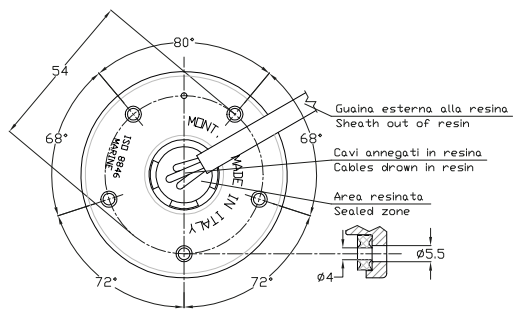

COLLEGAMENTI ELETTRICI ESTERNI  
 EXTERNAL ELECTRICAL SHEET

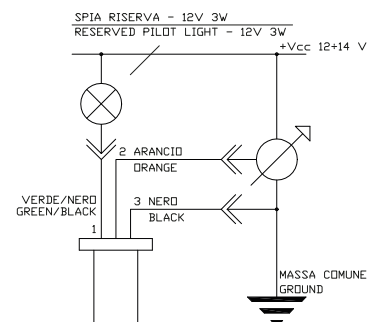

# INDICATORI LIVELLO CARBURANTE

## FUEL LEVEL GAUGES



G31826

Distinta materiali / Material list				
Rif. / Ref.	Descrizione / Part description	N. Pz. / Q.Ty	Materiale / Material	Note / Notes
1	Corpo sonda Gauge body	1	Alluminio EW-6060 T6 Aluminium EW-6060 T6	
2	Guarnizione Gasket	1	PA66 rinforzato vetro PA66 glass reinforced	Colore nero Black color
3	Guarnizione interna Internal gasket	1	Viton Viton	Colore verde Green color
4	Tappo Bottom plug	1	PA66 rinforzato vetro PA66 glass reinforced	Colore nero Black color
5	Galleggiante Float	1	PA espansa PA expanded	Colore: naturale Color: natural
6	Contatto strisciante Sliding contact	1	Bronzo fosforoso Phosphorous bronze	Doratura Gold plating
7	Circuito stampato Printed circuit	1	FR4 FR4	Doratura Gold plating
8	Guarnizione Gasket	1	NBR70 Resistente ai combustibili NBR70 Fuel resistance	Hardness 70 ±5 Sh.A
9				
10				

Specifiche tecniche / Technical specifications					
Lev.	Fuel level (f)			Resistance [Ω]	Imax [Ma]
	From [mm]		To [Mm]		
1	0,0		49,2	1,00 ± 1,00	350
2	49,2		77,0	3,00 ± 1,50	300
3	77,0		107,5	5,00 ± 1,50	300
4	107,5		138,0	9,75 ± 1,75	145
5	138,0		168,5	14,50 ± 2,00	145
6	168,5		199,0	19,25 ± 2,25	145
7	199,0		229,5	24,00 ± 2,50	145
8	229,5		260,0	28,75 ± 2,75	145
9	260,0		290,5	33,25 ± 3,25	145
10	290,5		320,5	38,00 ± 3,50	145
11	320,5		351,5	42,75 ± 3,75	145
12	351,5		382,0	47,50 ± 4,00	145
13	382,0		412,5	52,25 ± 4,25	145
14	412,5		443,0	59,25 ± 4,75	120
15	443,0		468,0	66,00 ± 5,00	120
	468,0	<-	Ling		
	483,0	<-	Ltot		
	433,0	<-	Lris		

G31207-01

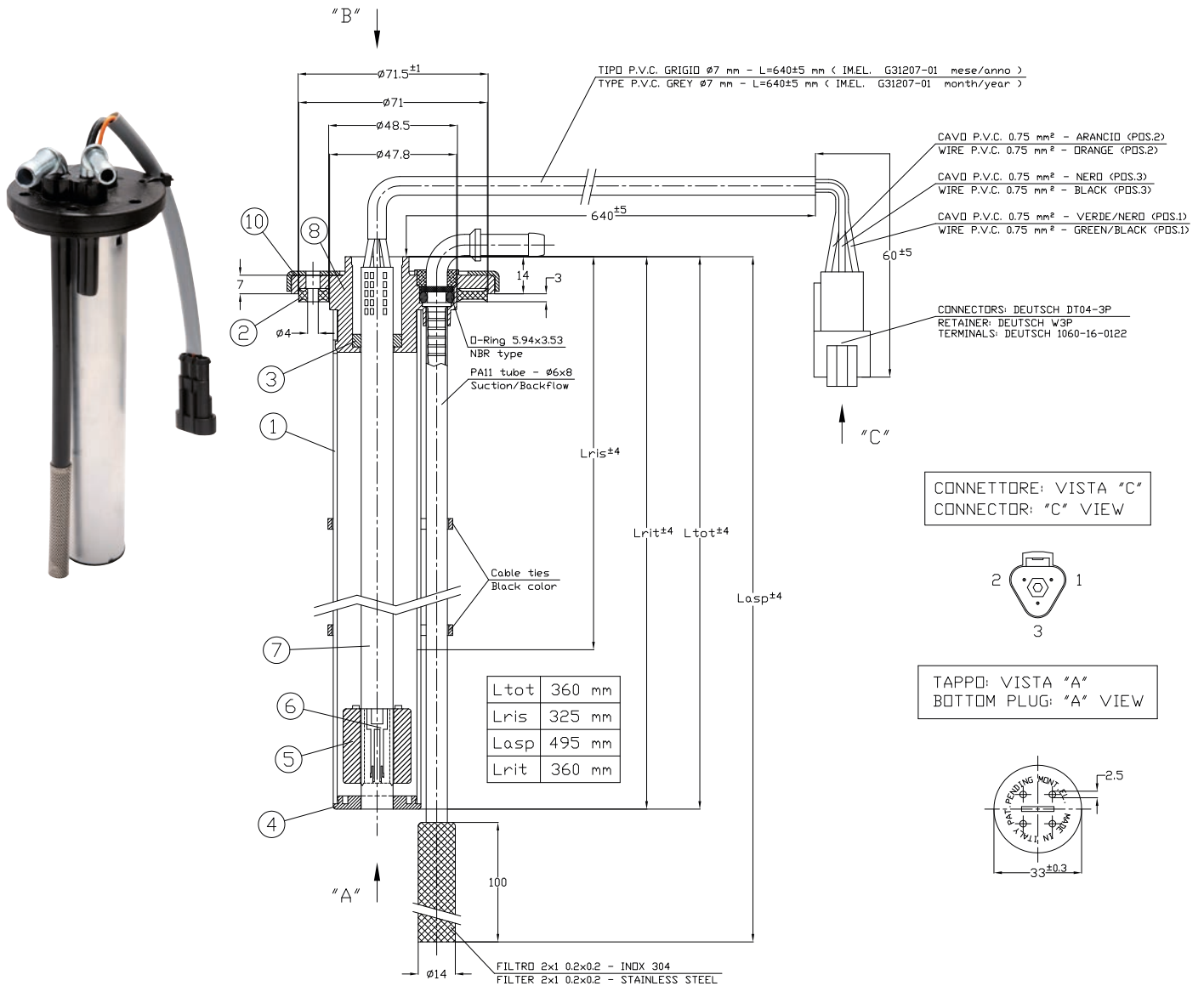

FLANGIA: VISTA "B"  
FLANGE: "B" VIEW

COLLEGAMENTI ELETTRICI ESTERNI  
EXTERNAL ELECTRICAL SHEET

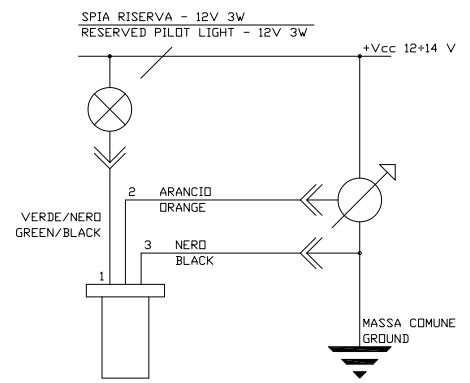
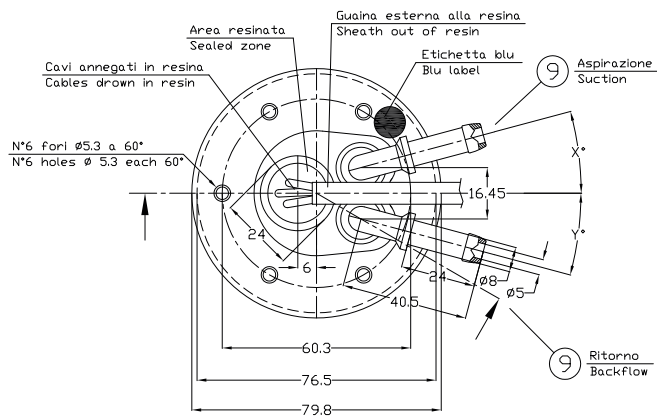

X°	~0°	Le quote degli angoli sono indicative
Y°	~0°	Angle dimensions are approximate



# INDICATORI LIVELLO CARBURANTE

## FUEL LEVEL GAUGES



G31207-01

Distinta materiali / Material list				
Rif. / Ref.	Descrizione / Part description	N. Pz. / Q.Ty	Materiale / Material	Note / Notes
1	Corpo sonda Gauge body	1	PVC PVC	Colore nero Black color
2	Guarnizione Gasket	1	Mescola TB2-71 (Tipo NBR) Mixture TB2-71 (NBR Type)	Hardness 70 ±5 Sh.A
3	Guarnizione interna Internal gasket	1	Viton Viton	
4	Tappo Bottom plug	1	PVC PVC	Colore grigio Grey color
5	Galleggiante Float	1	PA espansa PA expanded	
6	Contatto strisciante Sliding contact	1	Bronzo fosforoso Phosphorous bronze	Doratura Gold plating
7	Circuito stampato Printed circuit	1	FR4 FR4	Doratura Gold plating
8	Flangia Flange	1	PA6 30% rinforzato vetro PA6 30% glass reinforced	Colore nero Black color
9	Aspirazione/ritorno Suction/Backflow	2	Acciaio tropicalizzato Steel with wether protection	
10	Controflangia Top flange	1	FePO2 tropicalizzato FePO2 with wether protection	

Specifiche tecniche / Technical specifications				
Livello Lev.		Resistenza in uscita Sender unit output [Ω]	Max corrente ammessa Max current intensity [mA]	
1	FULL	4.5 < R < 6.5	145	
2	-	23.5 < R < 27.5	100	
3	-	42.5 < R < 48.5	100	
4	3/4	61.5 < R < 69.5	70	
5	-	85.0 < R < 90.5	70	
6	-	106.0 < R < 119.0	60	
7	-	132.0 < R < 147.0	60	
8	HALF	157.5 < R < 175.5	60	
9	-	171.5 < R < 191.5	60	
10	-	186.0 < R < 207.0	60	
11	-	200.0 < R < 223.0	60	
12	1/4	214.5 < R < 238.5	60	
13	-	240.0 < R < 267.0	60	
14	-	266.0 < R < 295.5	60	
15	EMPTY	310.5 < R < 344.5	45	

G31230-01

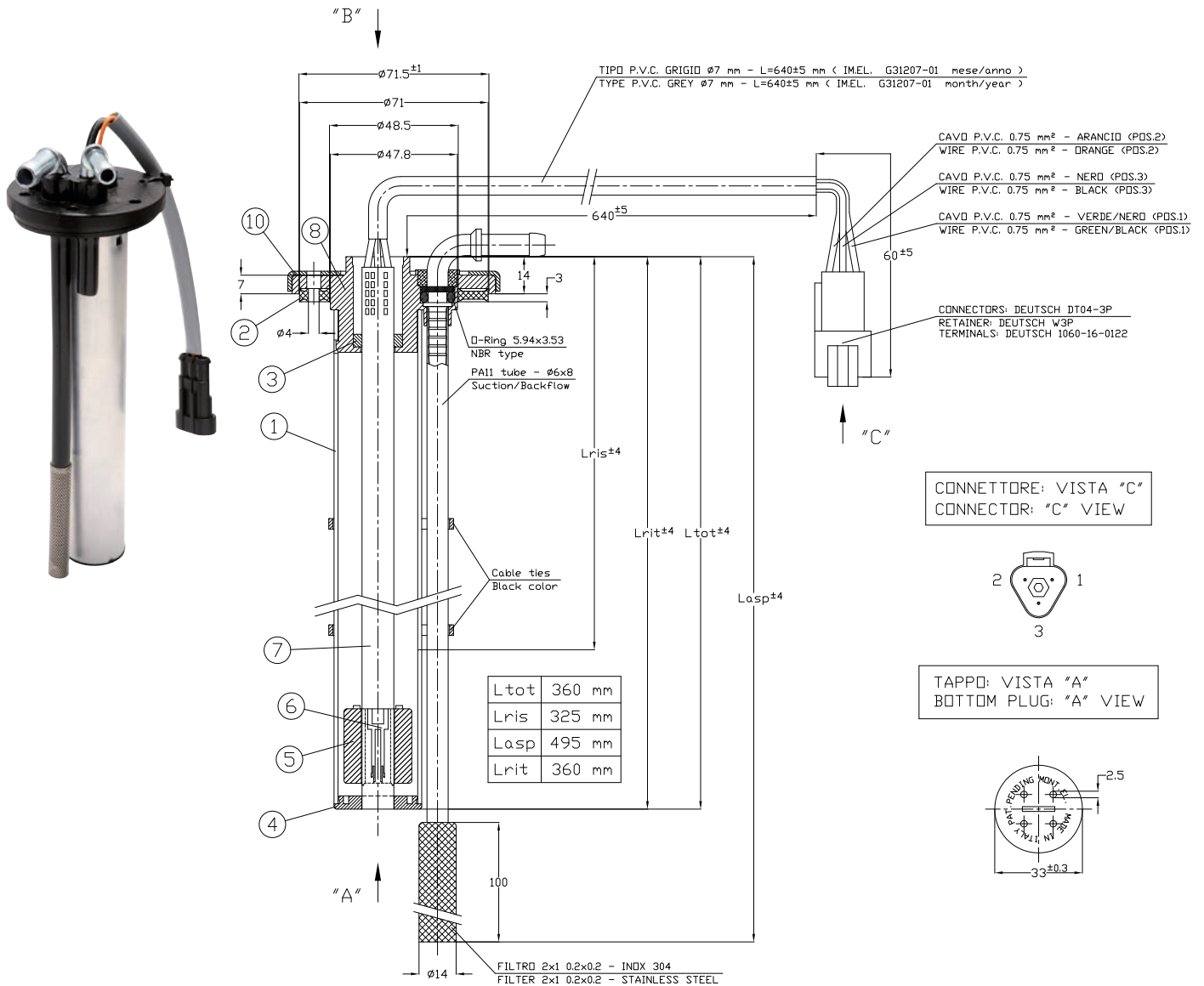

FLANGIA: VISTA "B"  
 FLANGE: "B" VIEW

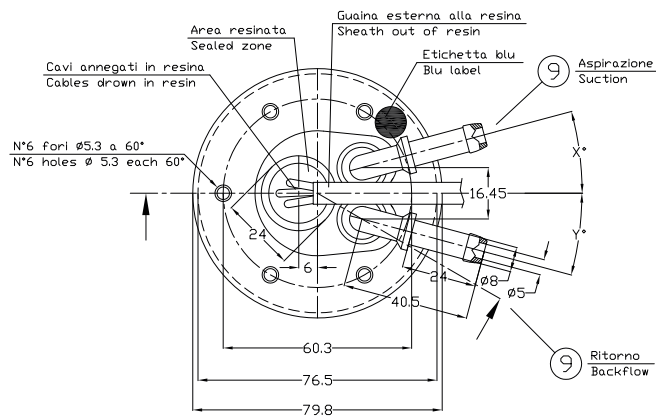

X°	~0°	Le quote degli angoli sono indicative
Y°	~0°	Angle dimensions are approximate

COLLEGAMENTI ELETTRICI ESTERNI  
 EXTERNAL ELECTRICAL SHEET

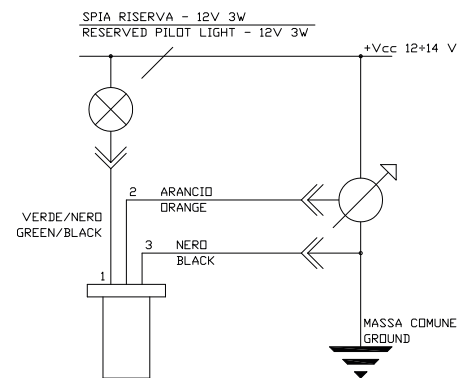

# INDICATORI LIVELLO CARBURANTE

## FUEL LEVEL GAUGES



G31230-01

Distinta materiali / Material list				
Rif. / Ref.	Descrizione / Part description	N. Pz. / Q.Ty	Materiale / Material	Note / Notes
1	Corpo sonda Gauge body	1	PVC PVC	Colore nero Black color
2	Guarnizione Gasket	1	Mescola TB2-71 (Tipo NBR) Mixture TB2-71 (NBR Type)	Hardness 70 ±5 Sh.A
3	Guarnizione interna Internal gasket	1	Viton Viton	
4	Tappo Bottom plug	1	PVC PVC	Colore grigio Grey color
5	Galleggiante Float	1	PA espansa PA expanded	
6	Contatto strisciante Sliding contact	1	Bronzo fosforoso Phosphorous bronze	Doratura Gold plating
7	Circuito stampato Printed circuit	1	FR4 FR4	Doratura Gold plating
8	Flangia Flange	1	PA6 30% rinforzato vetro PA6 30% glass reinforced	Colore nero Black color
9	Aspirazione/ritorno Suction/Backflow	2	Acciaio tropicalizzato Steel with wether protection	
10	Controflangia Top flange	1	FePO2 tropicalizzato FePO2 with wether protection	

Specifiche tecniche / Technical specifications				
Livello Lev.		Resistenza in uscita Sender unit output [Ω]	Max corrente ammessa Max current intensity [mA]	
1	FULL	4.5 < R < 6.5	145	
2	-	23.5 < R < 27.5	100	
3	-	42.5 < R < 48.5	100	
4	3/4	61.5 < R < 69.5	70	
5	-	71.0 < R < 80.0	70	
6	-	85.0 < R < 95.5	70	
7	-	99.5 < R < 111.5	70	
8	HALF	113.5 < R < 127.0	70	
9	-	133.0 < R < 148.0	70	
10	-	152.0 < R < 169.0	70	
11	-	177.5 < R < 197.5	70	
12	1/4	209.0 < R < 232.5	55	
13	-	240.0 < R < 267.0	55	
14	-	271.5 < R < 301.5	55	
15	EMPTY	316.0 < R < 351.0	45	

G31097

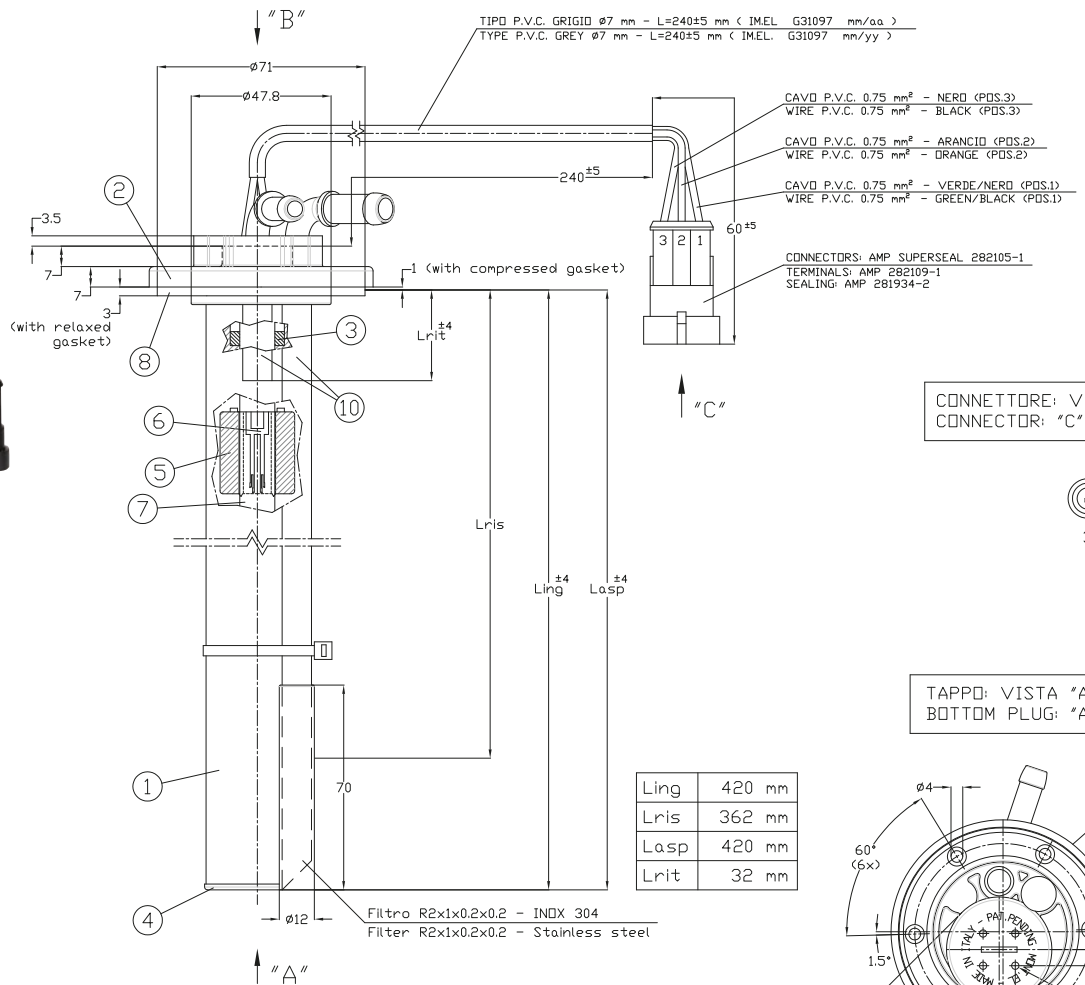

FLANGIA: VISTA "B"  
 FLANGE: "B" VIEW

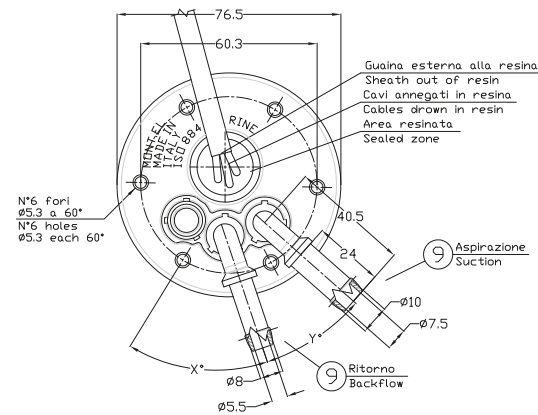

X°	50°	Le quote degli angoli sono indicative
Y°	30°	Angle dimensions are approximate

COLLEGAMENTI ELETTRICI ESTERNI  
 EXTERNAL ELECTRICAL SHEET

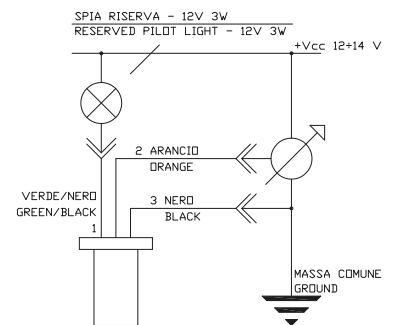

# INDICATORI LIVELLO CARBURANTE

## FUEL LEVEL GAUGES



G31097

Distinta materiali / Material list				
Rif. / Ref.	Descrizione / Part description	N. Pz. / Q.Ty	Materiale / Material	Note / Notes
1	Corpo sonda Gauge body	1	PVC	Colore nero Black color
2	Guarnizione Gasket	1	Mescola TB2-71 (Tipo NBR) Mixture TB2-71 (NBR Type)	Hardness 70 ±5 Sh.A
3	Guarnizione interna Internal gasket	1	Viton	
4	Tappo Bottom plug	1	PVC	Colore grigio Grey color
5	Galleggiante Float	1	PA espansa PA expanded	
6	Contatto strisciante Sliding contact	1	Bronzo fosforoso Phosphorous bronze	Doratura Gold plating
7	Circuito stampato Printed circuit	1	FR4	Doratura Gold plating
8	Flangia Flange	1	PA6 30% rinforzato vetro PA6 30% glass reinforced	Colore nero Black color
9	Aspirazione/ritorno Suction/Backflow	2	Acciaio tropicalizzato Steel with wether protection	
10	Controflangia Top flange	1	FePO2 tropicalizzato FePO2 with wether protection	

Specifiche tecniche / Technical specifications					
Lev.	Fuel level (f)			Resistance [Ω]	Imax [Ma]
	From [mm]		To [Mm]		
1	0,0		65,0	5,25 ± 1,75	145
2	65,0		162,5	25,25 ± 2,75	100
3	162,5		200,0	45,25 ± 3,75	100
4	200,0		225,0	65,50 ± 5,00	70
5	225,0		239,2	75,50 ± 5,50	70
6	239,2		253,4	90,50 ± 6,00	70
7	253,4		267,6	105,50 ± 7,00	70
8	267,6		281,8	120,50 ± 7,50	70
9	281,8		295,5	135,50 ± 8,50	70
10	295,5		309,2	150,50 ± 9,00	70
11	309,2		322,9	165,50 ± 10,00	70
12	322,9		336,6	185,50 ± 11,00	70
13	336,6		365,8	205,50 ± 12,00	70
14	365,8		395,0	267,50 ± 15,00	40
15	395,0		420,0	329,75 ± 18,25	40
	420,0	<-	Ling		
	435,0	<-	Ltot		
	362,0	<-	Lris		

G31074 - Comandi indicatore livello carburante con corpo in acciaio regolabile

G31074 - Adjustable fuel level sensor with steel body



Tabella valore Ohmico				
0	1/4	1/2	3/4	4/4
0-7	33-41	67-83	-	175-215
0°	14°	45°	-	90°



Schema elettrico/Electrical scheme

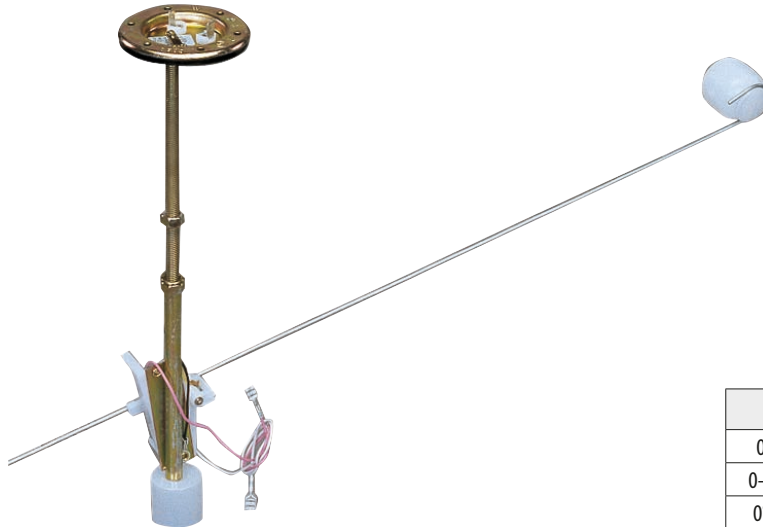
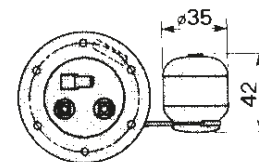
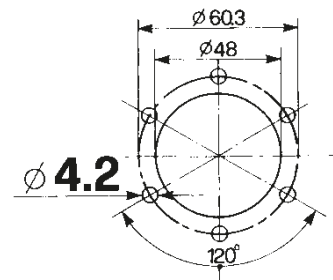
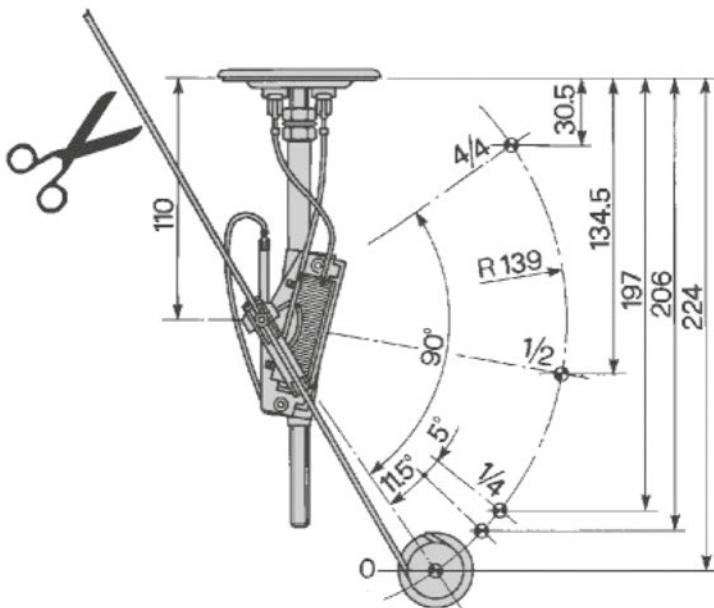
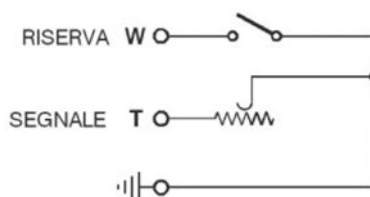

**S16194 TRASMETTITORE A TERMISTORE NTC 2000+500 OHM**

*S16194 - Thermistor sender*

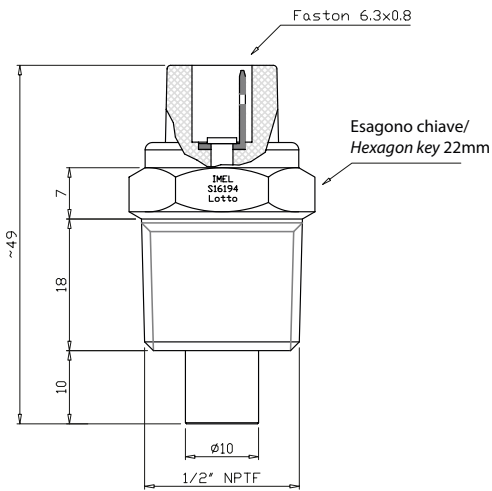

Caratteristica termo-resistiva/Termo-Resistivity specifications		
	Temperatura/ Temperature °C	Resistenza/Resistance Ohm +/-5%
	40	1.400
	50	955
	60	665
	70	470
	80	340
	90	249
	100	188
	110	139
	120	106
	130	81
	140	63
	150	51

Specifiche tecniche / Technical specifications	
Tensione di lavoro/ Voltage	12/24V DC
Protezione elettrica/ Electrical protection	IP65
Temp. d'utilizzo/ Usage temperature	-30 +170°C
Coppia di serraggio/ Clamping	15 Nm
Corpo trasm./ Sender	Ottone/Brass - CW614N
Torretta portacontatti/ Contact tower	Nylon 6/6 nero

**S16257 TRASMETTITORE A TERMISTORE NTC 2000+500 OHM**

*S16257 - Thermistor sender*

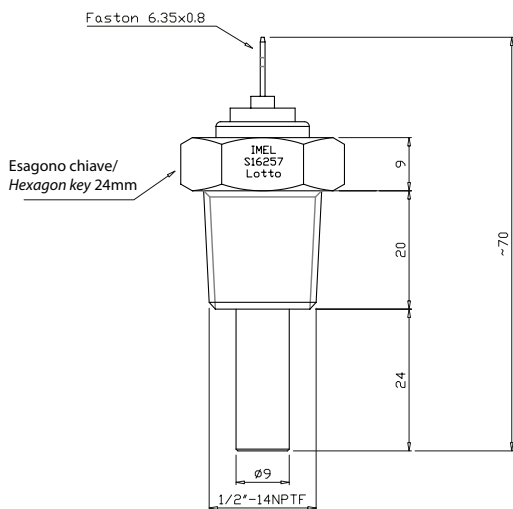

Caratteristica termo-resistiva/Termo-Resistivity specifications		
	Temperatura/ Temperature °C	Resistenza/Resistance Ohm +/-5%
	40	1.400
	50	955
	60	665
	70	470
	80	340
	90	249
	100	188
	110	139
	120	106
	130	81
	140	63
	150	51

Specifiche tecniche / Technical specifications	
Tensione di lavoro/ Voltage	12/24V DC
Protezione elettrica/ Electrical protection	IP65
Temp. d'utilizzo/ Usage temperature	-30 +170°C
Coppia di serraggio/ Clamping	15 Nm
Corpo trasm./ Sender	Ottone - CW614N
Torretta portacontatti/ Contact tower	Pocan nero

**S16276 TRASMETTITORE A TERMISTORE NTC 2000+500 OHM**

*S16276 - Thermistor sender*

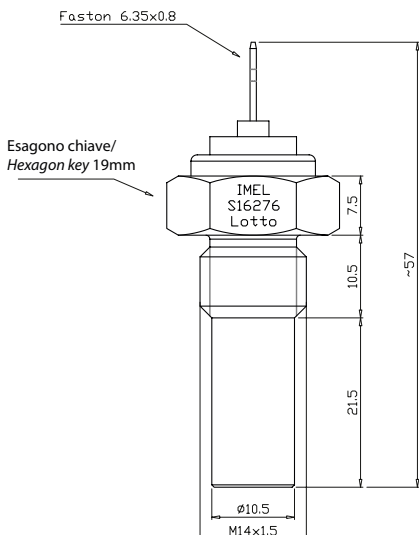

Caratteristica termo-resistiva/Termo-Resistivity specifications		
	Temperatura/ Temperature °C	Resistenza/Resistance Ohm +/-5%
	40	1.400
	50	955
	60	665
	70	470
	80	340
	90	249
	100	188
	110	139
	120	106
	130	81
	140	63
	150	51

Specifiche tecniche / Technical specifications	
Tensione di lavoro/ Voltage	12/24V DC
Protezione elettrica/ Electrical protection	IP65
Temperatura d'uti- lizzo/ Usage temperature	-30 +170°C
Coppia di serraggio/ Clamping	15 Nm
Corpo trasm./ Sender	Ottone - CW614N
Torretta portacontatti/ Contact tower	Pocan nero

### S16277 TRASMETTITORE A TERMISTORE NTC 2000+500 OHM

S16277 - Thermistor sender

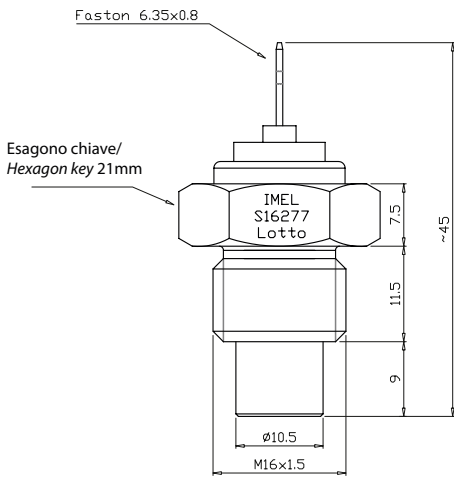

Caratteristica termo-resistiva/Termo-Resistivity specifications		
	Temperatura/ Temperature °C	Resistenza/Resistance Ohm +/-5%
	40	1.400
	50	955
	60	665
	70	470
	80	340
	90	249
	100	188
	110	139
	120	106
	130	81
	140	63
150	51	

Specifiche tecniche / Technical specifications	
Tensione di lavoro/ Voltage	12/24V DC
Protezione elettrica/ Electrical protection	IP65
Temp. d'utilizzo/ Usage temperature	-30 +170°C
Coppia di serraggio/ Clamping	20 Nm
Corpo trasm./ Sender	Ottone - CW614N
Torretta portacontatti/ Contact tower	Pocan nero

### S16277.T TRASMETTITORE A TERMISTORE NTC 2000+500 OHM

S16277.T - Thermistor sender

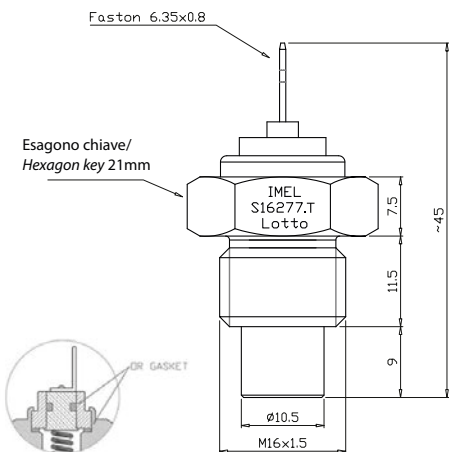

Caratteristica termo-resistiva/Termo-Resistivity specifications		
	Temperatura/ Temperature °C	Resistenza/Resistance Ohm +/-5%
	40	1.400
	50	955
	60	665
	70	470
	80	340
	90	249
	100	188
	110	139
	120	106
	130	81
	140	63
150	51	

Specifiche tecniche / Technical specifications	
Tensione di lavoro/ Voltage	12/24V DC
Protezione elettrica/ Electrical protection	IP66
Temp. d'utilizzo/ Usage temperature	-30 +170°C
Coppia di serraggio/ Clamping	20 Nm
Corpo trasm./ Sender	Ottone - CW614N
Torretta portacontatti/ Contact tower	Pocan nero

### S16277.1 TRASMETTITORE A TERMISTORE NTC 1000/B=3650 - RITORNO ISOLATO

S16277.1 - Thermistor sender. Insulated return.

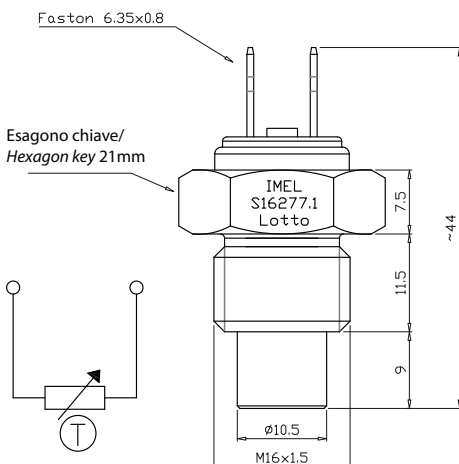

Temperatura riferimento °C	Temperatura misurata (°C) (tolleranza +/-4°C)
50	58
60	61
70	73
80	82
90	92
100	101
110	110
120	120
130	128
140	135
150	148

Specifiche tecniche / Technical specifications	
Tensione di lavoro/ Voltage	12/24V DC
Protezione elettrica/ Electrical protection	IP65
Temp. d'utilizzo/ Usage temperature	-30 +160°C
Coppia di serraggio/ Clamping	20 Nm
Corpo trasm./ Sender	Ottone
Torretta portacontatti/ Contact tower	Nylon 6/6 nero



**S16278 TRASMETTITORE A TERMISTORE NTC 2000+500 OHM**

*S16278 - Thermistor sender*

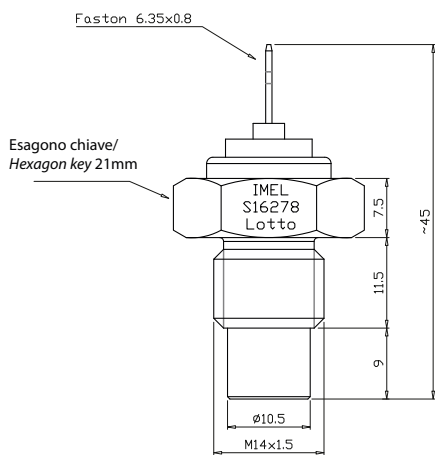

Caratteristica termo-resistiva/Termo-Resistivity specifications		
	Temperatura/ Temperature °C	Resistenza/Resistance Ohm +/-5%
	40	1.400
	50	955
	60	665
	70	470
	80	340
	90	249
	100	188
	110	139
	120	106
	130	81
	140	63
150	51	

Specifiche tecniche / Technical specifications	
Tensione di lavoro/ Voltage	12/24V DC
Protezione elettrica/ Electrical protection	IP65
Temp. d'utilizzo/ Usage temperature	-30 +170°C
Coppia di serraggio/ Clamping	15 Nm
Corpo trasm./ Sender	Ottone - CW614N
Torretta portacontatti/ Contact tower	Pocan nero

**S16279 TRASMETTITORE A TERMISTORE NTC 2000+500 OHM**

*S16279 - Thermistor sender*

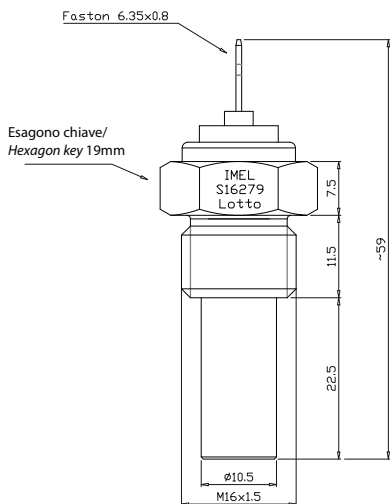

Caratteristica termo-resistiva/Termo-Resistivity specifications		
	Temperatura/ Temperature °C	Resistenza/Resistance Ohm +/-5%
	40	1.400
	50	955
	60	665
	70	470
	80	340
	90	249
	100	188
	110	139
	120	106
	130	81
	140	63
150	51	

Specifiche tecniche / Technical specifications	
Tensione di lavoro/ Voltage	12/24V DC
Protezione elettrica/ Electrical protection	IP65
Temp. d'utilizzo/ Usage temperature	-30 +170°C
Coppia di serraggio/ Clamping	15 Nm
Corpo trasm./ Sender	Ottone - CW614N
Torretta portacontatti/ Contact tower	Pocan nero

**S16281 TRASMETTITORE A TERMISTORE NTC 2000+500 OHM**

*S16281 - Thermistor sender*

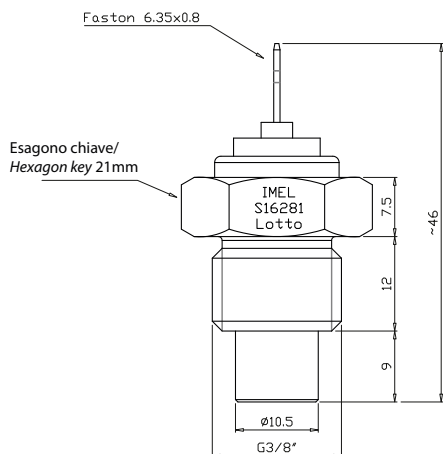

Caratteristica termo-resistiva/Termo-Resistivity specifications		
	Temperatura/ Temperature °C	Resistenza/Resistance Ohm +/-5%
	40	1.400
	50	955
	60	665
	70	470
	80	340
	90	249
	100	188
	110	139
	120	106
	130	81
	140	63
150	51	

Specifiche tecniche / Technical specifications	
Tensione di lavoro/ Voltage	12/24V DC
Protezione elettrica/ Electrical protection	IP65
Temp. d'utilizzo/ Usage temperature	-30 +170°C
Coppia di serraggio/ Clamping	15 Nm
Corpo trasm./ Sender	Ottone - CW614N
Torretta portacontatti/ Contact tower	Pocan nero

### S16282 TRASMETTITORE A TERMISTORE NTC 2000+500 OHM

S16282 - Thermistor sender

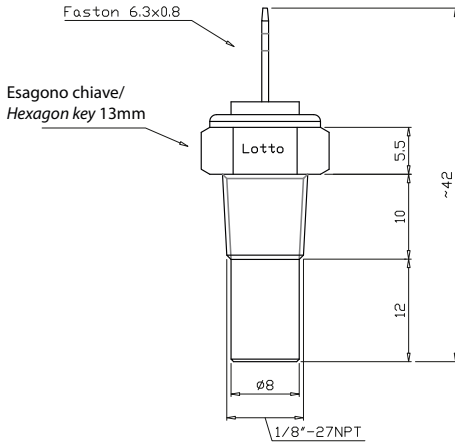

Caratteristica termo-resistiva/Termo-Resistivity specifications		
	Temperatura/ Temperature °C	Resistenza/Resistance Ohm +/-5%
	40	1.400
	50	955
	60	665
	70	470
	80	340
	90	249
	100	188
	110	139
	120	106
	130	81
	140	63
	150	51

Specifiche tecniche/ Technical specifications	
Tensione di lavoro/ Voltage	12/24V DC
Protezione elettrica/ Electrical protection	IP65
Temp. d'utilizzo/ Usage temperature	-30 +170°C
Coppia di serraggio/ Clamping	15 Nm
Corpo trasm./ Sender	Ottone - CW614N
Torretta portacontatti/ Contact tower	Nylon 6/6 bianco

### S16283 TRASMETTITORE A TERMISTORE NTC 2000+500 OHM

S16283 - Thermistor sender

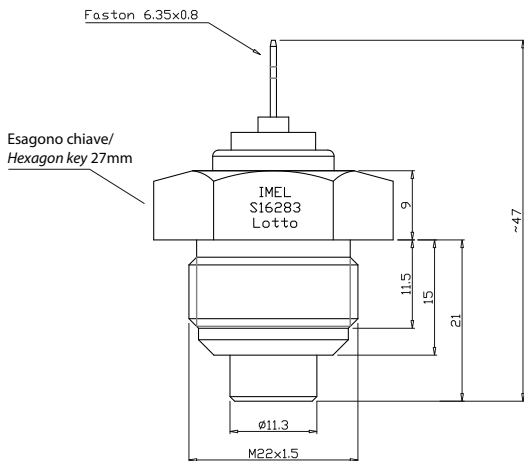

Caratteristica termo-resistiva/Termo-Resistivity specifications		
	Temperatura/ Temperature °C	Resistenza/Resistance Ohm +/-5%
	40	1350
	50	880
	60	600
	70	420
	80	290
	90	215
	100	150
	110	115
	120	90
	130	64
	140	50
	150	40,5

Specifiche tecniche/ Technical specifications	
Tensione di lavoro/ Voltage	12/24V DC
Protezione elettrica/ Electrical protection	IP66
Temp. d'utilizzo/ Usage temperature	-30 +170°C
Coppia di serraggio/ Clamping	25 Nm
Corpo trasm./ Sender	Ottone - CW614N
Torretta portacontatti/ Contact tower	Pocan nero

### S16290 TRASMETTITORE A TERMISTORE NTC 1000/B=3650 - RITORNO ISOLATO

S16290 - Thermistor sender. Insulated return.

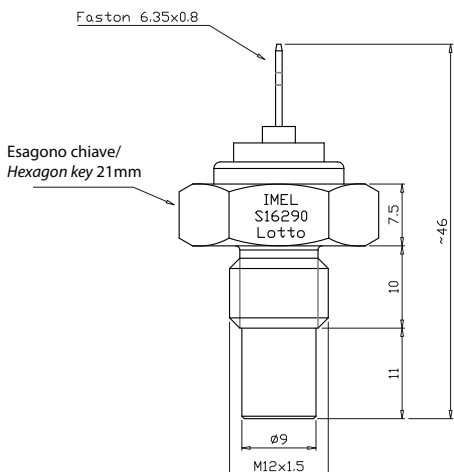

Caratteristica termo-resistiva/Termo-Resistivity specifications		
	Temperatura/ Temperature °C	Resistenza/Resistance Ohm +/-5%
	40	1350
	50	880
	60	600
	70	420
	80	290
	90	215
	100	150
	110	115
	120	90
	130	64
	140	50
	150	40,5

Specifiche tecniche/ Technical specifications	
Tensione di lavoro/ Voltage	12/24V DC
Protezione elettrica/ Electrical protection	IP65
Temp. d'utilizzo/ Usage temperature	-30 +160°C
Coppia di serraggio/ Clamping	15 Nm
Corpo trasm./ Sender	Ottone - CW614N
Torretta portacontatti/ Contact tower	Nylon 6/6

**S16035 - Interruttore termometrico**

S16035 - Thermometric switch

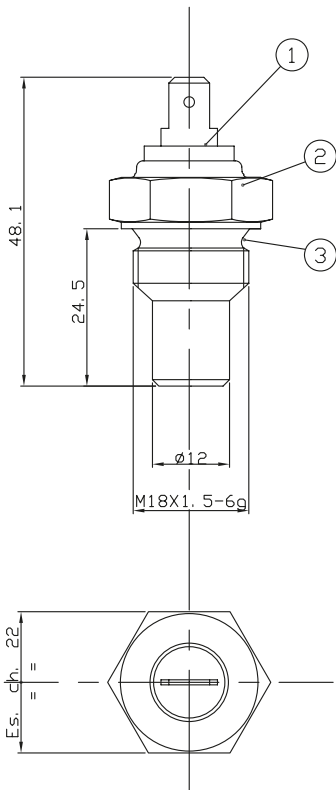

**LEGENDA**

1. Cappuccio costampato in nylon 66 colore nero 30% fibra di vetro con innesto lamellare tipo "A" (6,3 x 0,8) TAB. 91319 in P OT 67 Snt. oppure in FePO2 Znt. Brill.
2. Corpo in ottone P. OT58Pb Trf. H20D Tab. 53440
3. Gola per guarnizione di tenuta

**PRESCRIZIONI**

- L'interruttore porta marcato il nome del fornitore e la data di fabbricazione secondo NP. 0.. 00013
- L'interruttore deve essere a tenuta ermetica
- Coppia di serraggio: 15 Nm.
- Collaudare secondo capitolato 9. 92347

**TARATURA**

- Con incremento di 1°C/min. La chiusura del contatto deve avvenire alla temperatura di 93° ± 3°

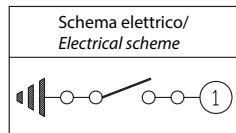

**LEGEND**

1. molded cover in nylon 66 colour black 30% glass fiber with lamellar graf type "A" (6,3 x 0,8) tab,91319 in P OT snt or in FePO2 znt Brill.
2. brass body P.OT58Pb Trf.H20D Tab 53440
3. groove for seals

**PRESCRIPTION**

- switch have the supplier name marked on it and the manufacture date according to NP
- the switch have to be ermetic
- clamping couple
- test according to specifications 9,92347

**SETTING**

- with increase of 1°C/min. The contact closing have to be at the temperature of 93°+/- 3°

**S16096 - Interruttore comando spia temperatura acqua**

S16096 - Water temperature warning light switch

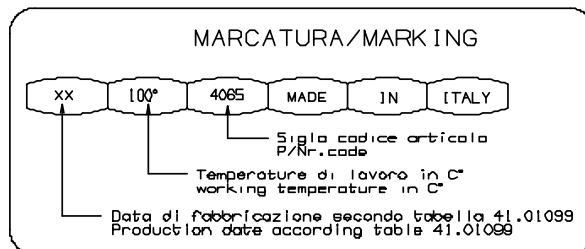
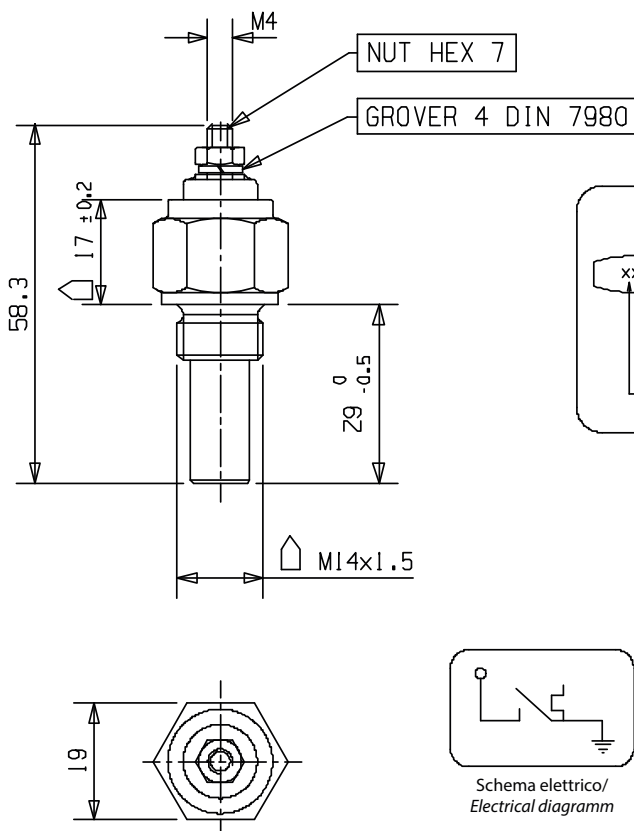

Circuito/Circuit	
Contatto normalmente aperto Normally open circuit	
Chiusura contatto Closing circuit	◇ 100° ± 5°C 212° ± 9°C
Apertura contatto Opening circuit	◇ ≥ 85° C ≥ 185° F

**S16113 - Termostato bimetallico CH29 M22x1.5 92°C NA**

S16113 - Bimetallic thermostat

**008 92°C NA**

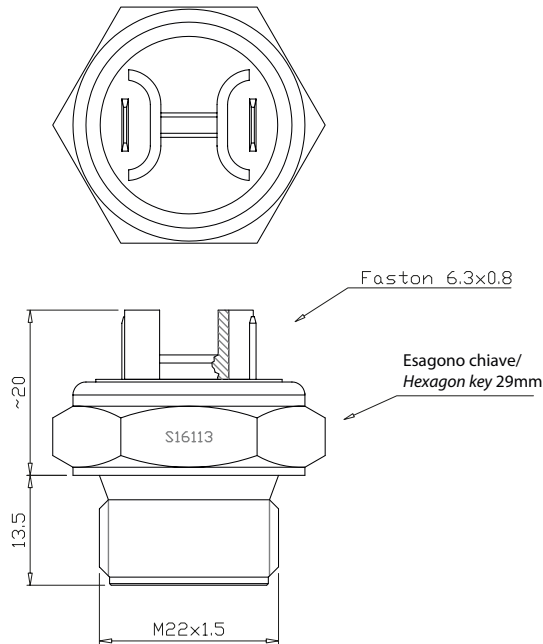

Dati tecnici / Technical data	
Tensione di lavoro / Voltage	12 VDC - 7A
	24 VDC - 5A
Temperature d'intervento / Operation temperature	92°C
Tolleranza d'intervento / Operation tolerance	+/- 3,5°C
Differenziale / Differential	13°C
Contatti elettrici / Electrical contacts	NA
Protezione elettrica / Electrical protection	IP65
Coppia di serraggio / Clamping couple	30 Nm
Temp. d'impiego / Use temperature	-20+120° C

Materiali / Material	
Contatti elettrici / Electrical contacts	Argentati / Silvery
Corpo / Body	Ottone / Brass OT 58
Torretta portacontatti / Contact tower	Nylon rosso / Red nylon

**S16128**

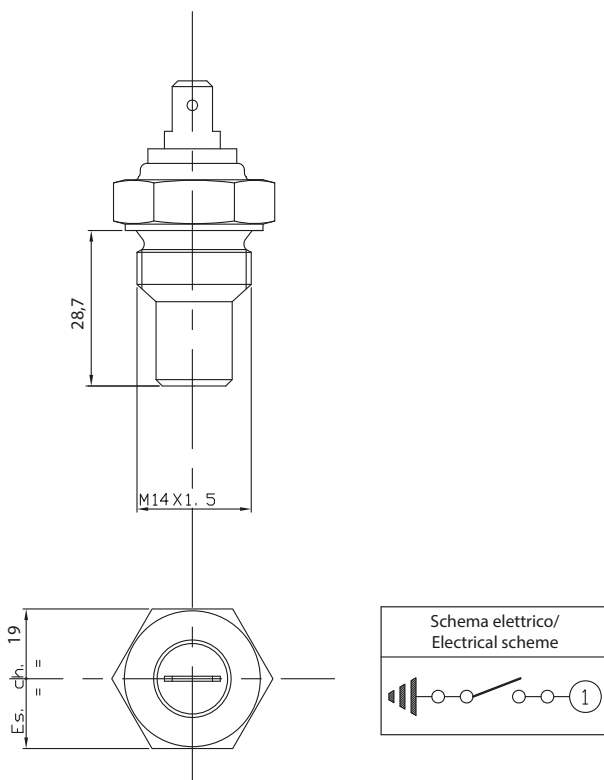

Dati tecnici / Technical data	
Allarme/Alarm	110°
Filettatura/Threading	14x1,5
Chiave/Wrench	19
12V	X
24V	X
Taratura/Output	N.A.
Connessione/Connection	Singolo/1 Pole

**S16142 - Sensore di allarme alta temperatura**

*S16142 - High temperature alarm contacts*

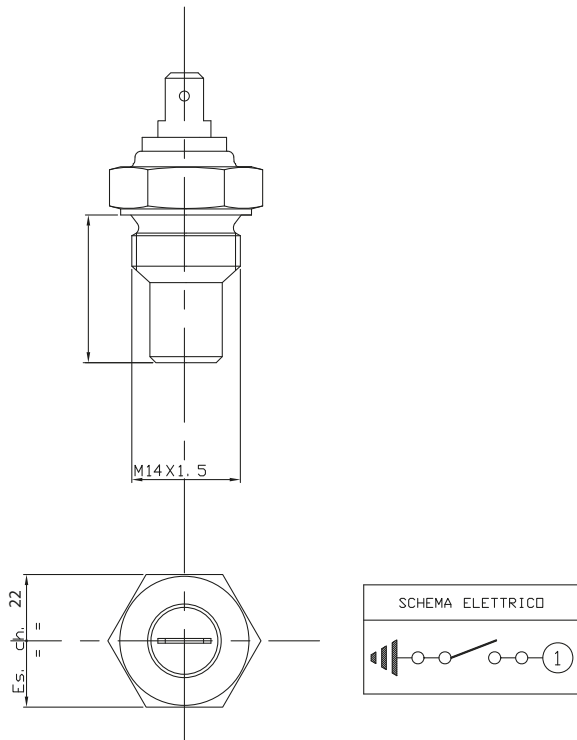

Dati tecnici / Technical data	
Allarme / Alarm	105°
Filettatura / Threading	14x1,5
Chiave / Wrench	22
12V	X
24V	X
Taratura / Output	N.A.
Connessione / Connection	Singolo/1 Pole

**S16155 - Termostato bimetallico ritorno isolato**

*S16155 - Bimetallic with insulated return thermostat*

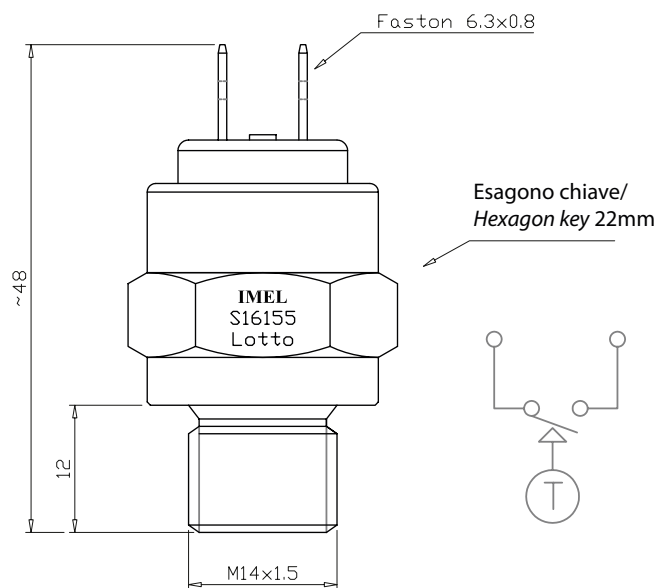

Dati tecnici / Technical data	
Tensione di lavoro / Voltage	12 /24/48V DC - 3A
Protezione elettrica / Electrical protection	IP65 Faston esclusi
Temperatura d'utilizzo / Usage temperature	-20 + 120°C
Coppia di serraggio / Closing couple	15 NM
Corpo trasm. / Sender body	Ottone/Brass - CW614N
Contatto elettrico / Electrical contact	Normalmente aperto/ Normally open
Temperatura d'intervento / Operation temperature	87°C
Tolleranza d'intervento / Operation tolerance	+/-3,5°C
Isteresi / Hysteresis	12-14°C
Torretta portacontatti / Contact tower	Nylon 6/6

S16191

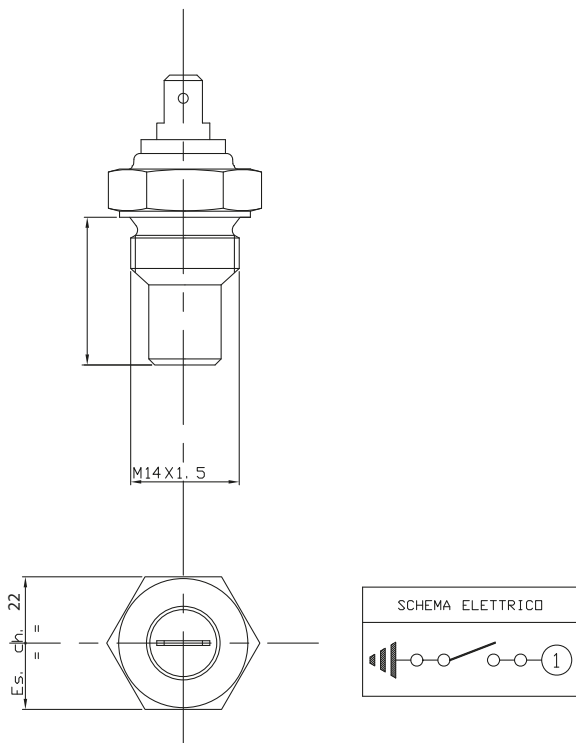

Dati tecnici / Technical data	
Allarme / Alarm	130°
Filettatura / Threading	14x1,5
Chiave / Wrench	22
12V	X
24V	X
Taratura / Output	N.A. / N.O.
Connessione / Connection	Singolo/1 Pole

**S16286 - Termostato bimetallico**

S16286 - Bimetallic thermostat

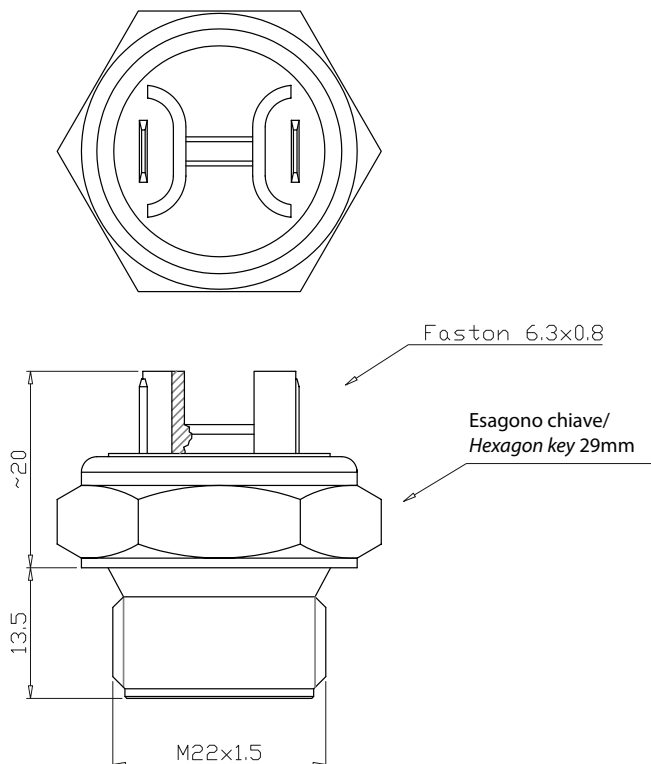

Dati tecnici / Technical data	
Potenza max di lavoro / Max usage power	120V AC - 15A (resist.) 240V AC - 10A (resist.) 277V AC - 7,2A (resist.)
Tensione di lavoro / Voltage	12/24VDC - 120W
<b>Temperature d'intervento/ Operation temperature</b>	80°C
Tolleranza d'intervento / Operation tolerance	+/- 3,2°C
Differenziale / Differential	13-15°C
Contatti elettrici / Electrical contacts	NA
Protezione elettrica / Electrical protection	IP54
Coppia di serraggio / Closing couple	3 Kgm
Temperatura d'impiego / Usage temperature	-20+130°C

Materiali / Material	
Contatti elettrici / Electrical contacts	Argento
Corpo / Body	Ottone OT 58
Torretta portacontatti / Contact tower	Nylon 6/6 rosso

**S16289 - Termostato bimetallico**

*S16289 - Bimetallic thermostat*

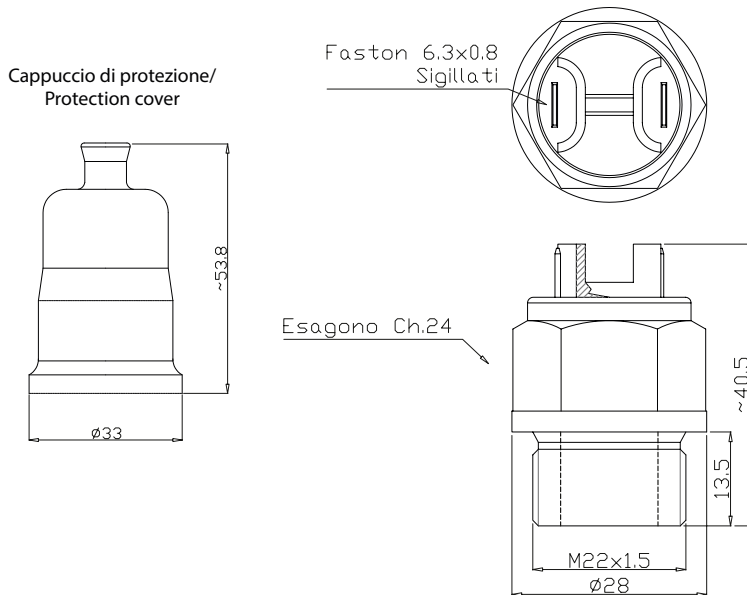

Dati tecnici / Technical data	
Potenza max di lavoro / Max usage power	120V AC - 15A (resist.)
Tensione di lavoro / Voltage	240V AC - 10A (resist.)
	277V AC - 7,2A (resist.)
	12/24VDC - 120W
<b>Temperature d'intervento / Operation temperature</b>	70°C
Tolleranza d'intervento / Operation tolerance	+/- 3,2°C
Differenziale / Differential	13-15°C
Contatti elettrici / Electrical contacts	NA
Protezione elettrica / Electrical protection	IP54
Coppia di serraggio / Closing couple	3 Kgm
Temperatura d'impiego / Usage temperature	-20+130° C

Materiali / Material	
Contatti elettrici / Electrical contacts	Argento
Corpo / Body	Ottone OT 58
Torretta portacontatti / Contact tower	Nylon 6/6 rosso

**Note:** Termostato tipo "Snap contact", ideale per il controllo della minima o massima temperatura in impianti industriali, motori ecc.

Per ottenere la massima precisione d'intervento, è consigliabile installare il termostato in modo che esso sia strettamente a contatto con il fluido o la sorgente di calore da controllare.

**Note:** thermostat tipe "snap contact" suitable for the control of the minimum or maximum temp in industrial installations, engines etc.

**S16299 - Termostato**

*S16299 - Thermostat*

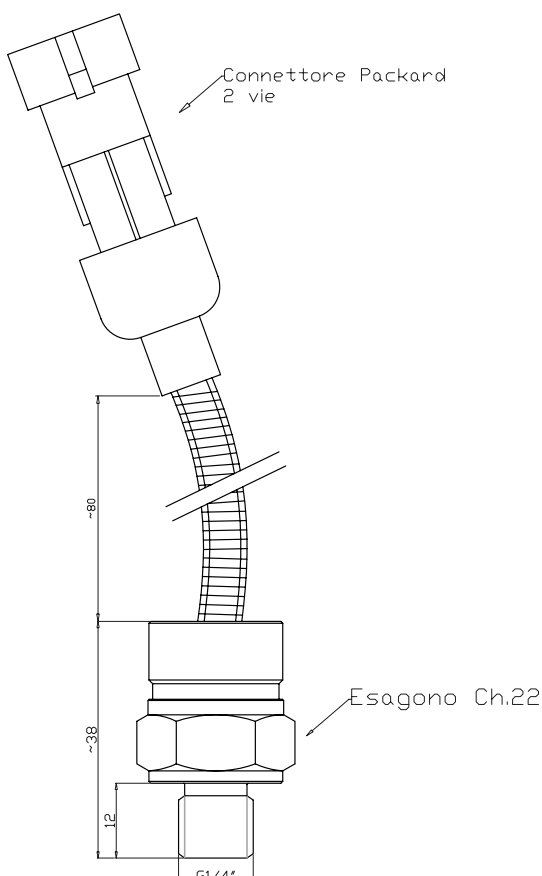

Dati tecnici / Technical data	
Carico elettrico/Charged	240V AC - 4A (resist.)
	24V DC - 5A (resist.)
<b>Temperature d'intervento / Operation temperature</b>	108°C
Tolleranza d'intervento / Operation tolerance	+/- 3,5°C
Isteresi / Hysteresis	~ 15°C
Contatto elettrico / Electrical contact	Normalmente aperto
Protezione elettrica / Electrical protection	IP65
Coppia di serraggio / Closing couple	2,5 Kgm
Temperatura ambiente / Room temperature	-20/+120° C

Materiali / Material	
Contatti elettrici / Electrical contacts	Argento / Silver
Sigillante/Sealant	Resina epossidica / Epoxy resin

### S16087 - Trasmittitore spia temperatura acqua

S16087 - Water temperature sender with warning light switch

/BLADES 6,3x0,8

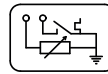
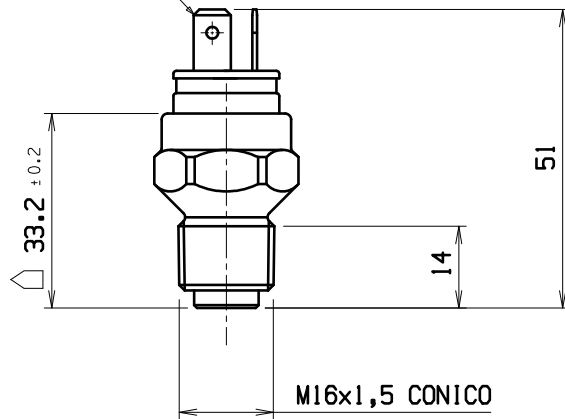

SCHEMA ELETTRICO  
SCHEMATIC DIAGRAM

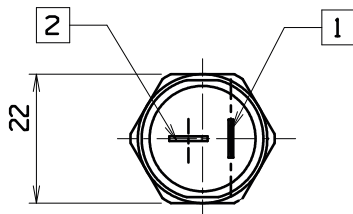

Circuito/Circuit (1 - ⊕)		
Contatto normalmente aperto/ Normally open circuit		
Chiusura contatto/ Closing circuit	◇	115° ± 5°C 239° ± 9°F
Apertura contatto/ Opening circuit	◇	90° MIN 194° MIN

Temperatura/ Temperature	Resistenza/ Resistance
25°C	2053 Ω (1888-2300)
85°C	238 Ω (212-264)
100°C	151 Ω (136-166)

### S16135 - Trasmittitore spia temperatura acqua

S16135 - Water temperature sender with warning light switch

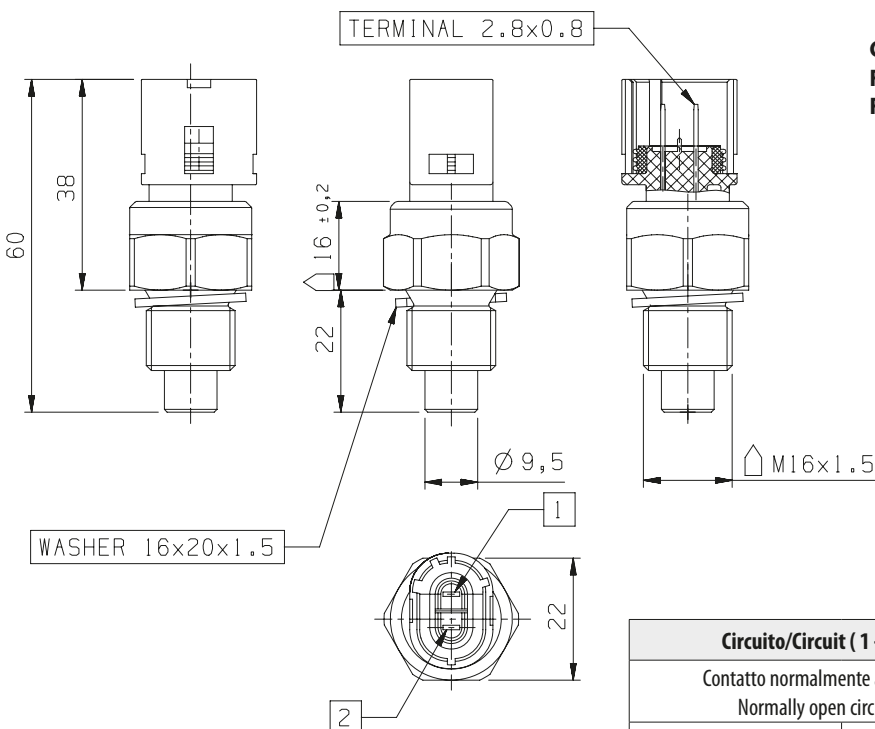

Controparte/Opposite part  
F23035 connettore/Connector  
F23036 terminali/Pins

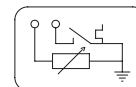

SCHEMA ELETTRICO  
SCHEMATIC DIAGRAM

Circuito/Circuit (1 - ⊕)		
Contatto normalmente aperto/ Normally open circuit		
Chiusura contatto/ Closing circuit	◇	115° ± 5°C 239° ± 9°F
Apertura contatto/ Opening circuit	◇	95° MIN 203 MIN

Temperatura/ Temperature	Resistenza/ Resistance
25°C	2697 Ω (2292-3183)
85°C	284 Ω (248-320)
100°C	179 Ω (159-199)



# TERMISTORI + TERMOCONTATTI

THERMISTOR + THERMOCONTACT



## S16158 - Termistore + termocontatto 16x1.5

S16158 - Thermistor + thermocontact 16x1.5

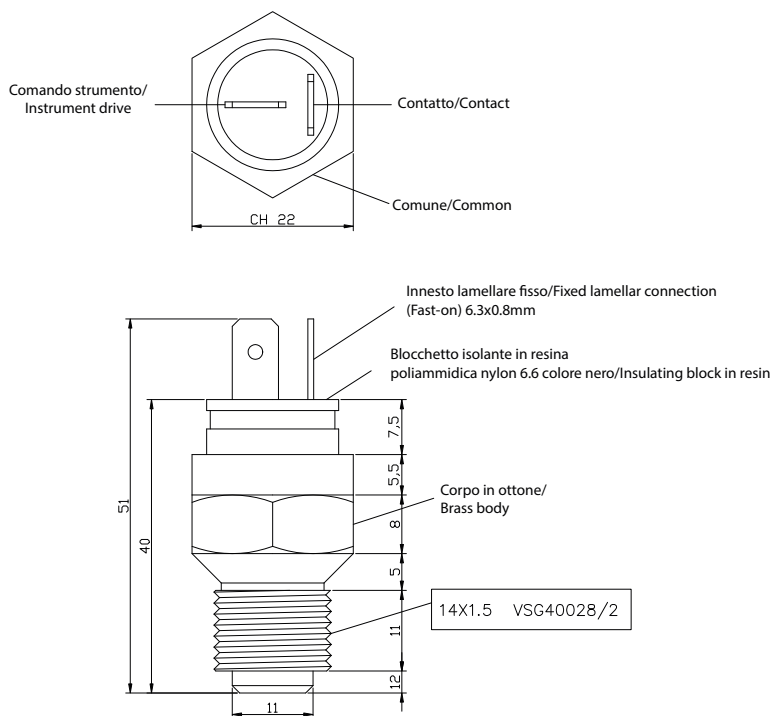

### CARATTERISTICHE TECNICHE

- Circuito unipolare
- Tensione di alimentazione 6÷24V
- Temp. chiusura contatto 107°C +/- 3°C
- Tutte le dimensioni sono in mm

### TECHNICAL FEATURES

- Unipolar circuit
- Power supply 6÷24V
- Closing contact temp. 107°C +/- 3°C
- All the dimension are in mm

°C	40	60	70	80	90	100	120
Ω	1020	501,8	355,1	258,2	189,4	142,5	83,7

## S16158.STG - Termistore + termocontatto VSG400 28/2S

S16158.STG - Thermistor+thermocontact VSG400 28/2S

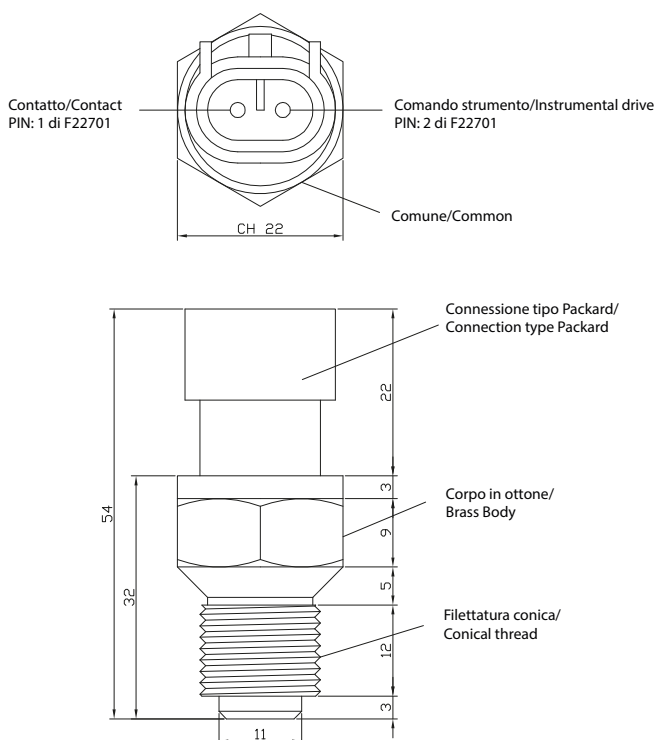

### CARATTERISTICHE TECNICHE/ TECHNICAL FEATURES

- Circuito unipolare
- Tensione di alimentazione 6÷24V
- Temp. chiusura contatto 107°C +/- 3°C
- Tutte le dimensioni sono in mm

### TECHNICAL FEATURES

- Unipolar circuit
- Power supply 6÷24V
- Closing contact temp. 107°C +/- 3°C
- All the dimension are in mm

Filettatura/Thread	Chiusura contatto/Closing contact
14x1,5	107± 3°C

°C	40	60	70	80	90	100	120
Ω	1020	501,8	355,1	258,2	189,4	142,5	83,7

### S16181 - Trasmittitore spia temperatura acqua

S16181 - Water temperature sender with warning light switch

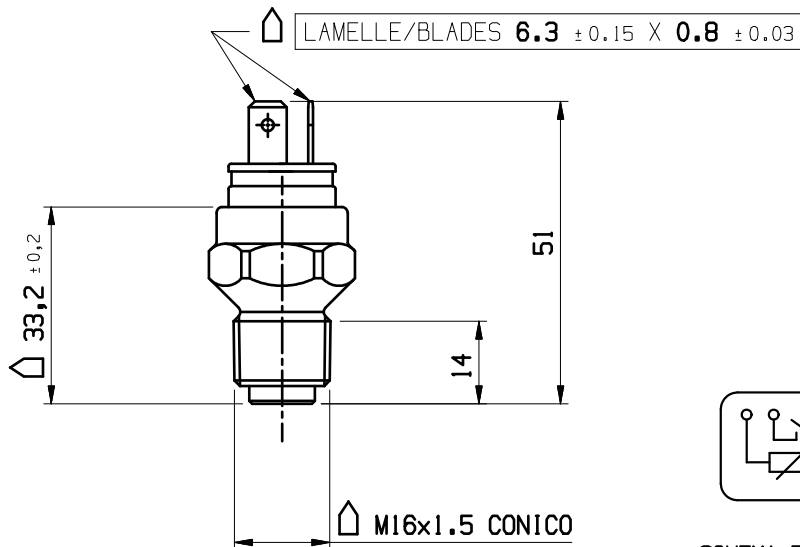

Circuito/Circuit (1 - ⊕)		
Contatto normalmente aperto Normally open circuit		
Chiusura contatto Closing circuit		107° ± 5°C 225° ± 9°F
Apertura contatto Opening circuit		92° MIN 198° MIN

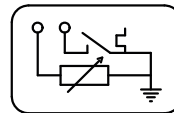

SCHEMA ELETTRICO  
SCHEMATIC DIAGRAM

Temperatura/ Temperature	Resistenza/ Resistance
25°C	2053 Ω (1888-2300)
85°C	238 Ω (212-264)
100°C	151 Ω (136-166)

### S16242 - Termistore NTC 2000+500 Ohm con termocontatto 105°C NA

S16242 - Thermistor NTC 2000+500 ohm with thermocontact 105°C NA

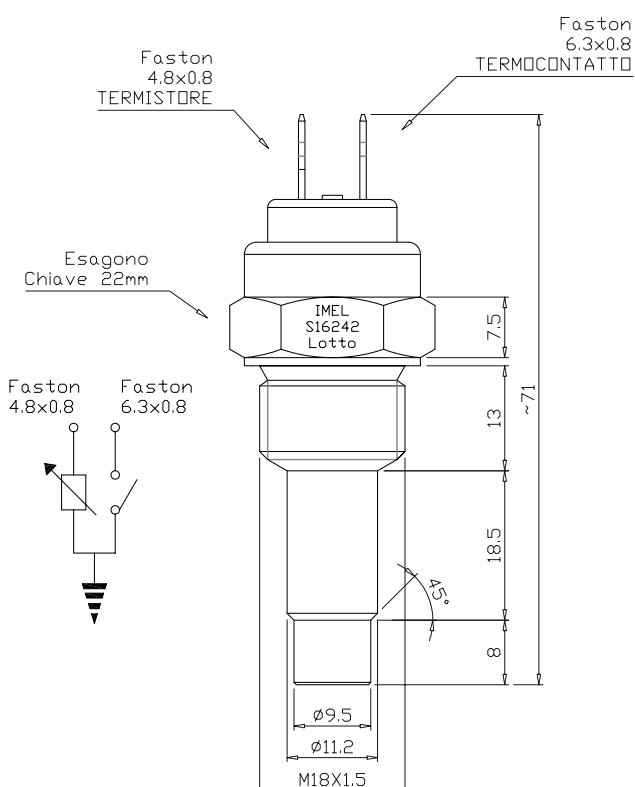

Caratteristica termo-resistiva Termistore (Faston 4.8x0.8)		
	Temperatura/ Temperature °C	Resistenza/ Resistance Ohm +/-5%
	40	1.350
	50	880
	60	600
	70	420
	80	290
	90	215
	100	150
	110	115
	120	90
	130	64
	140	50
150	40,5	

Dati tecnici - Termostato (Faston 6.3x0.8) Technical data - (Faston 6.3x0.8)	
Tensione di lavoro/ Voltage	12/24VDC
Potenza carico/ Charged power	3W
Temperatura di chiusura/ Closing temperature	105°C
Temperatura di apertura/ Opening temperature	100°C
Tolleranza d'intervento/ Operation tolerance	+/-4°C
Protezione elettrica/ Electrical protection	IP65

Materiali / Material	
Contatti elettrici/ Electrical contacts	Argentati
Corpo/Body	Ottone - CW614N
Torretta portacontatti/Contact tower	POCAN NERO
Coppia di serraggio/ Closing couple	15Nm
Temp. d'impiego/ Usage temperature	-30 + 140°C

### S16259 - Termometrico Termistore

S16259 - Thermometrical thermistor

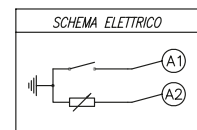
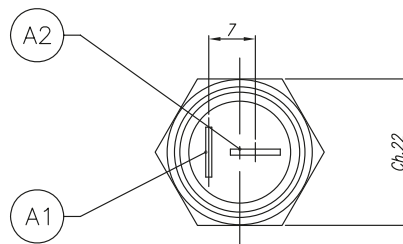
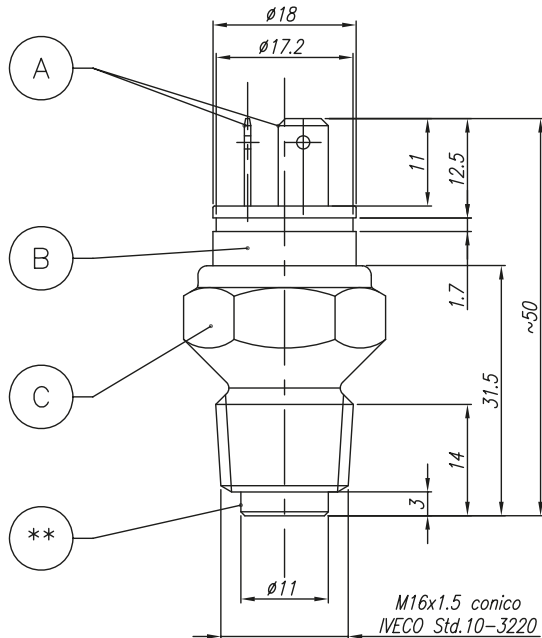

#### LEGENDA

- a) Spine lamellari fisse (con foro) tipo A - TAB.91319, in ottone POT67 Lmt.H10 - TAB.53441, stagnato Cu/Sn/A sec. CAP9.57422  
 A1) All'indicatore ottico  
 A2) Al termometro elettrico  
 B) Blocchetto isolante in resina poliammidica nylon 6,6+30%F.V., colore nero  
 c) Corpo in ottone POT58 Pb Trf H10D - TAB. 53440

#### PRESCRIZIONI

- Il trasmettitore - interruttore deve portare marcato sulle facce dell'esagono, l'identificazione del fornitore, il catalogo dell'apparecchio il valore della taratura, la data di fabbricazione secondo IVECO STD. 10-0812 e il marchio IVECO
- Le spine lamellari possono assumere, rispetto al corpo esagonale, un orientamento diverso da quello indicato a disegno
- La zona contrassegnata con \*\* deve essere bagnata completamente dal liquido di cui occorre misurare la temperatura
- Taratura interruttore: con incremento di temperatura di 1°C/min., il contatto dell'interruttore deve chiudersi a 120 ± 3°C
- Taratura trasmettitore:
 

25°C	2391.6Ω ± 10.6%
60°C	557Ω ± 8.0%
110°C	106.8Ω ± 5.0%
- Tensione: 12-24V
- Coppia di serraggio: 30Nm classe II - Tab.01390 (+5%/-15%)  
 Previa applicazione di LOCTITE su filettatura
- Collaudare secondo capitolato 9.92346

#### LEGEND

- a) fixed lamellar plugs(with hole) type ATAB91319, in brass POT-67lmt H10-TAB53441, tinning Cu/Sn/A sec CAP9,57422  
 A1) to the optical indicator  
 A2) to the electrical thermometer  
 B) insulated block in polyamide resin nylon 6,6+30%FV black colour  
 C) brass body POT58PB TrfH10D-TAB 53440

#### PRESCRIPTION

- the sender/switch have to be marked on the esagonal face, the supplier identification, the device catalogue, the setting value, the fabrication date according to IVECO STD 10-0812 and the IVECO stamp
- the lamellar plugs could assume, as regards as to the esagonal body, a different sense of direction to the one indicated in the drawing
- the zone marked with \*\* have to be completely wet to the liquid of which it is necessary to measure the temperature
- setting switch: with temperature increase of 1°C/min, the switch contact have to be closed at 120+/-3°C
- setting sender:
 

25°C	2391.6Ω ± 10.6%
60°C	557Ω ± 8.0%
110°C	106.8Ω ± 5.0%
- voltage 12-24V
- closing couple: 30nm classe II tab 01390 (+5%/15%) subject to the application of Loctite on the thread
- testing according to the specifications 9,92346



## Indicatori livello carburante e sensori Fuel Level Gauges & Sensors



### **AMA IMEL DIVISIONE DI AMA S.p.a.**

Via Repubblica, 7  
41011 Campogalliano, MO (Italy)  
Tel. 0522 636963 - Fax 0522 695753  
www.ama.it - ama@ama.it

Headquarter:

### **AMA S.p.a.**

Via Giacomo Puccini, 28  
42018 San MArtino in Rio (RE) Italy  
Tel. +39 0522 6369 (10 linee r.a.) Fax +39 0522 695753  
www.ama.it - ama@ama.it

**AZIENDA CON  
SISTEMA DI GESTIONE  
CERTIFICATO DA DNV  
= ISO 9001 =  
= ISO 14001 =**

CATALOGO TECNICO  
TECHNICAL CATALOGUE